

Rev	AWO #	Description	Date	Appr
-		RELEASED	3/12/15	

APPROVED: _____
 DATE: _____ TITLE: _____

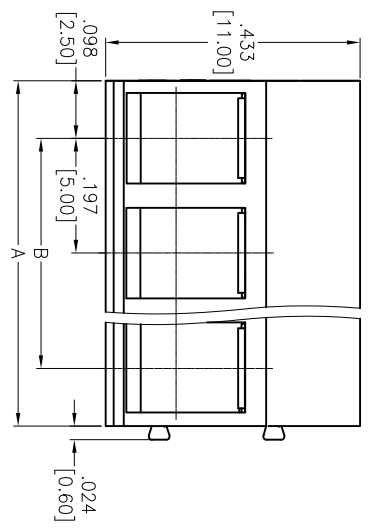
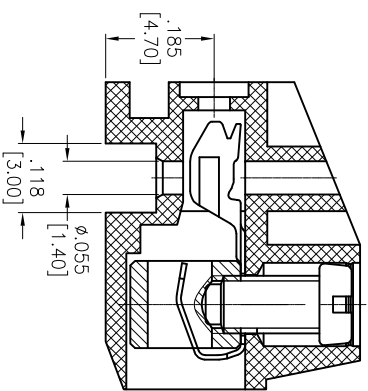
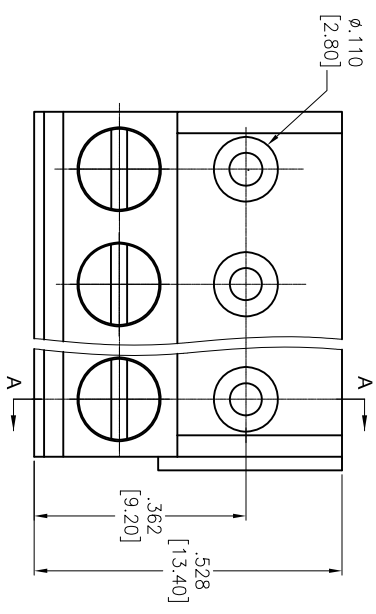

POSITIONS: 2 thru 24
 A = .197 [5.00] x No. of Positions
 B = .197 [5.00] x No. of Spaces

SPECIFICATIONS:
 Material: Insulator: PBT, rated UL 94V-0
 Insulator color: Black
 Clamp: Phosphor Bronze, Nickel plated
 Wire guard: Brass, Nickel plated
 Screw: Steel, M2.5/Zinc plated
 Electrical:
 Voltage rated: 300 V
 Current rated: 10 Amps
 Contact resistance: 20 mΩ
 Insulation resistance: 500 MΩ @ 500 VDC
 Wire range: 28-16AWG
 Withstanding voltage: 2000V AC/1 Min
 Torque: 0.4Nm, 3.6 Lb-in
 Strip length: 4.5-5mm
 Temperature Rating:
 Operating temperature: -40°C to +105°C
 Environmental:
 Lead free, RoHS compliant.

ADAM TECH

909 Rahway Avenue, Union, NJ 07083
 Phone: 908-687-5000 Fax: 908-687-5710

EURO BLOCK, .197 [5.00] PITCH

UNLESS OTHERWISE SPECIFIED ALL DIMENSIONS ARE INCHES [MM]	
TOLERANCES: EXCEPT AS NOTED	
INCHES	HOLES
.X ± .10	ØXX ± .10
.XX ± .020	ØXXX ± .015
.XXX ± .015	ØXXXX ± .010
APPROVALS	DATE
DRAWN AY	3/12/15
CHECKED YC	3/12/15
APPROVED	

TITLE		SIZE	PART NO.	REV.
EURO BLOCK, .197 [5.00] PITCH		X	EBJA-XX-C-BK	-
REF:	S00067C	SCALE:	NTS	SHEET 1 OF 1



6 5 4 3 2 1