

4-bit Bidirectional Voltage-Level Translator for Open-Drain and Push-Pull Applications

Features

- Voltage Level Translator Without Direction-Control Signal
- Maximum Data Rates
 - 24Mbps (Push Pull)
 - 2Mbps (Open Drain)
- Power Supply Range:
 - A Port and VCCA: 1.1V to 3.6 V
 - B Port and VCCB: 1.65 V to 5.5 V
 - $V_{CCA} \leq V_{CCB}$
- Pull Up Resistors are Integrated in A Port and B Port
- No Power-Supply Sequencing Required: Either VCCA or VCCB Can be Ramped First
- Support Ultra-Low Power Consumption Mode with OE Pin is Low Voltage Level
- Latch -Up Performance Exceeds $\pm 200\text{mA}$ Under JESD 78 Standard
- FOWLP 1.87mm \times 1.37mm-12B Package

Applications

- I²C / SMBus
- UART
- GPIO
- Handheld Devices Interface

General Description

AW39114 is a 4-bit high-performance voltage-level translator without direction control signal, which is a non-inverting converter and can be used to convert digital signal with mixed-voltage systems. It needs two separate power supply rails, with the A ports tracks the V_{CCA} ranging from 1.1V to 3.6 V, and the B ports tracks the V_{CCB} ranging from 1.65 V to 5.5 V. This makes the chip has capabilities of support both lower and higher logic signal levels translation between any of the 1.2V, 1.8 V, 2.5 V, 3.3 V, and 5 V voltage nodes.

The OE input circuit is supplied by VCCA. Meanwhile, OE is recommended to be tied to GND through an external pull-down resistor to ensure all I/O to be pulled to the supply voltage. No power supply sequencing requirements means either VCCA or VCCB can be powered up first, and OE should be enabled after both VCCA and VCCB are established.

Typical Application Circuit

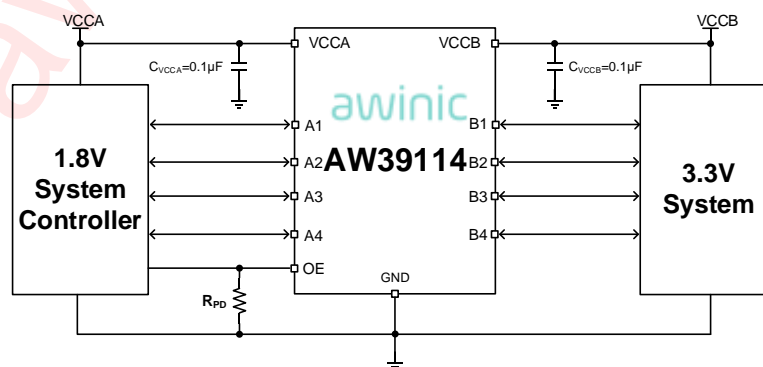

Figure 1 Typical Application Circuit of AW39114

Pin Configuration And Top Mark

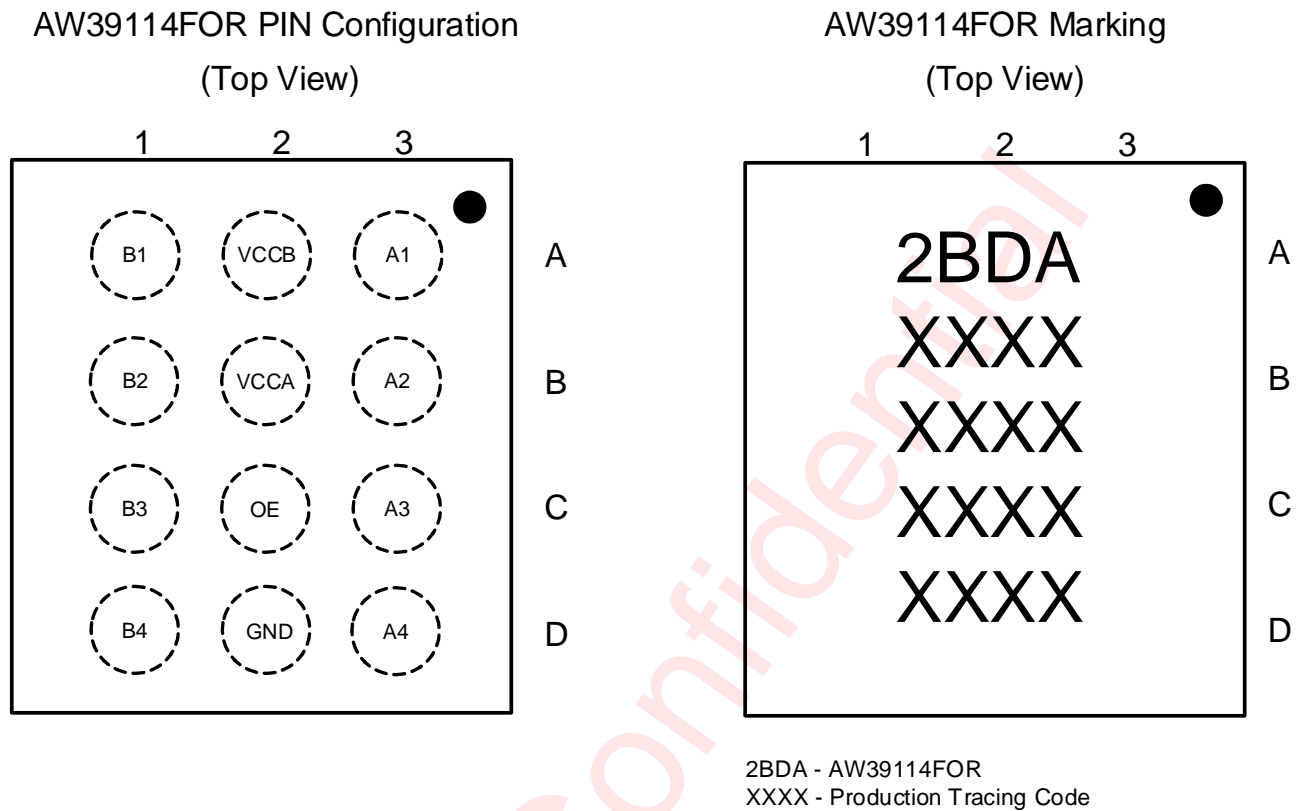

Figure 2 Pin Configuration and Top Mark

Pin Definition

Pin No.	Pin Name	Description
B2	VCCA	A-port supply voltage. $1.1\text{ V} \leq VCCA \leq 3.6\text{ V}$, $VCCA \leq VCCB$.
A3	A1	Input/output A1.
B3	A2	Input/output A2.
C3	A3	Input/output A3.
D3	A4	Input/output A4.
D2	GND	Ground.
C2	OE	Output enable.
A1	B1	Input/output B1.
B1	B2	Input/output B2.
C1	B3	Input/output B3.
D1	B4	Input/output B4.
A2	VCCB	B-port supply voltage. $1.65\text{ V} \leq VCCB \leq 5.5\text{ V}$.

NOTE: The Pin number of Pin 1 (Pin No.) is A3 instead of A1, and the Pin name is A1.

Functional Block Diagram

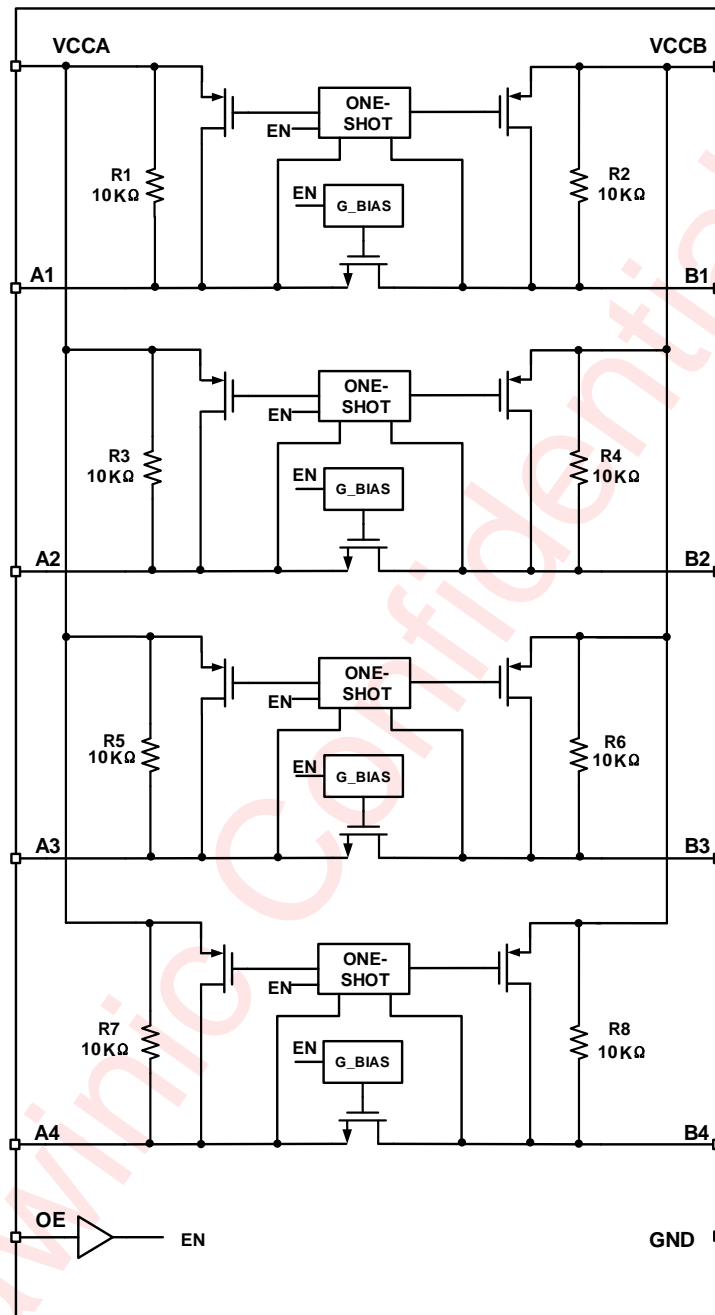

Figure 3 AW39114 Function Block

Typical Application Circuit

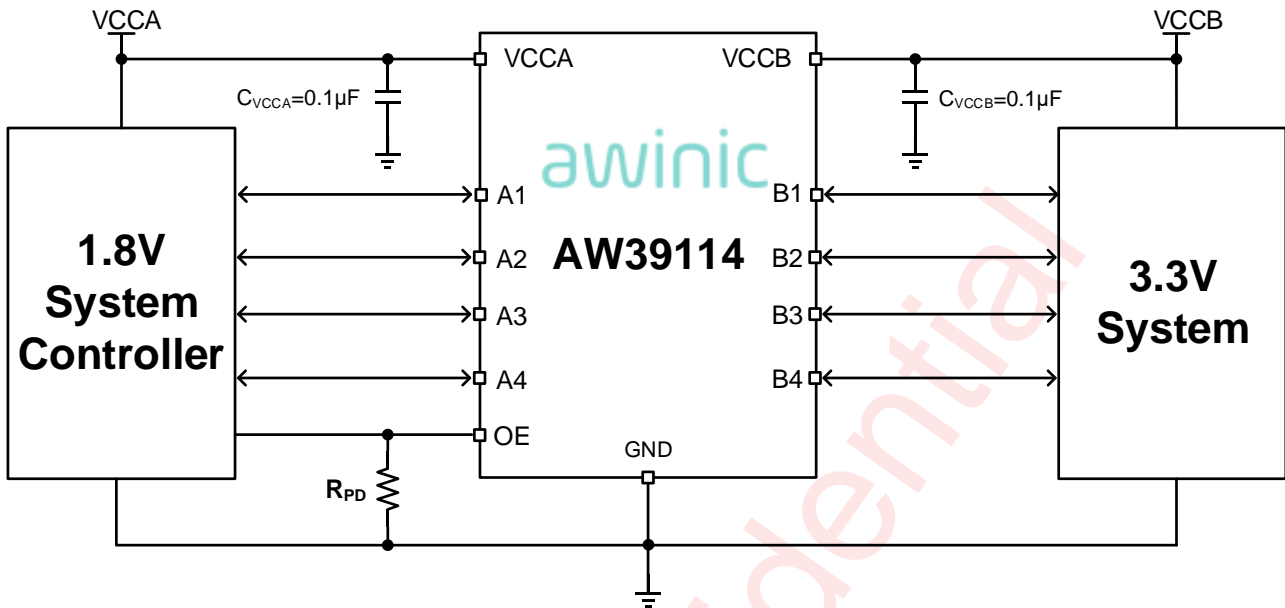

Figure 4 AW39114 Application Circuit

Notice for typical application circuits:

1. In any case, the A/B Ports Voltage cannot be higher than the VCCA/VCCB voltage. Otherwise, the leakage current will flow from A/B Ports to VCCA/VCCB.
2. The device driving the A/B ports must have the driving capacity at least ± 1 mA.

Ordering Information

Part Number	Temperature	Package	Marking	Moisture Sensitivity Level	Environmental Information	Delivery Form
AW39114FOR	-40°C~85°C	FOWLP 1.87mmx1.37mm-12B	2BDA	MSL1	ROHS+HF	4500 units/ Tape and Reel

Absolute Maximum Ratings(NOTE1)

PARAMETERS		MIN	MAX	UNIT
Supply voltage range V_{CCA} (NOTE2)		-0.5	5	V
Supply voltage range V_{CCB} (NOTE2)		-0.5	6.5	V
Input voltage range, V_I (NOTE2)	A port	-0.5	5	V
	B port	-0.5	6.5	V
Output voltage range in high or low state, V_O (NOTE2)	A port	-0.5	5	V
	B port	-0.5	6.5	V
Input clamp current, I_{IK}	$V_I < 0$		-50	mA
Output clamp current, I_{OK}	$V_O < 0$		-50	mA
Operating free-air temperature range		-40	85	°C
Operating junction temperature T_J		-40	125	°C
Storage temperature T_{STG}		-65	150	°C
Lead temperature (Soldering 10 seconds)			260	°C

NOTE1: Conditions out of those ranges listed in "absolute maximum ratings" may cause permanent damages to the device. In spite of the limits above, functional operation conditions of the device should within the ranges listed in "recommended operating conditions". Exposure to absolute-maximum-rated conditions for prolonged periods may affect device reliability.

NOTE2: With respect to GND.

ESD Rating And Latch Up

PARAMETERS	VALUE	UNIT
HBM (Human Body Model) (NOTE 3)	±2	kV
CDM(NOTE 4)	±1.5	kV
Latch-Up(NOTE 5)	+IT: 200 -IT: -200	mA

NOTE3: The human body model is a 100pF capacitor discharged through a 1.5kΩ resistor into each pin.

Test method: ESDA/JEDEC JS-001-2017

NOTE4: Test method: ESDA/JEDEC JS-002-2018

NOTE5: Test method: JESD78E

Recommended Operating Conditions

VCCI is the VCC associated with the input port

PARAMETERS		CONDITIONS		MIN	MAX	UNIT
V _{CCA}	Supply voltage for A port			1.1	3.6	V
V _{CCB}	Supply voltage for B port			1.65	5.5	V
V _{IH}	High-level input voltage	A-port	V _{CCA} =1.1V~1.95V V _{CCB} =1.65V~5.5V	V _{CCI} -0.3	V _{CCI}	V
			V _{CCA} =2.3V~3.6V V _{CCB} =1.65V~5.5V	V _{CCI} -0.4	V _{CCI}	V
		B-port	V _{CCA} =1.1V~3.6V V _{CCB} =1.65V~5.5V	V _{CCI} -0.4	V _{CCI}	V
		OE input	V _{CCA} =1.1V~3.6V V _{CCB} =1.65V~5.5V	V _{CCA} ×0.65	5.5	V
V _{IL}	Low-level input voltage	A-port	V _{CCA} =1.1V~3.6V V _{CCB} =1.65V~5.5V	0	0.15	V
		B-port	V _{CCA} =1.1V~3.6V V _{CCB} =1.65V~5.5V	0	0.15	V
		OE input	V _{CCA} =1.1V~3.6V V _{CCB} =1.65V~5.5V	0	V _{CCA} ×0.35	V
Δt/ΔV	Input transition rise or fall rate	A-port (NOTE6)	V _{CCA} =1.1V~3.6V V _{CCB} =1.65V~5.5V		10	ns/V
		B-port (NOTE6)	V _{CCA} =1.1V~3.6V V _{CCB} =1.65V~5.5V		10	ns/V
		Control input	V _{CCA} =1.1V~3.6V V _{CCB} =1.65V~5.5V		10	ns/V
T _A	Operating junction temperature T _A			-40	85	°C

NOTE6: The parameter is defined for push-pull driving.

Thermal Information

PARAMETERS	VALUE	UNIT
Junction-to-ambient thermal resistance θ _{JA}	120	°C /W

Electrical Characteristics

DC Electrical Characteristics

Operating under recommended conditions, $V_{CCA} \leq V_{CCB}$, $T_A=25^\circ\text{C}$ for typical values (unless otherwise noted)

PARAMETER		TEST CONDITION	$V_{CCA}(V)$	$V_{CCB}(V)$	MIN	TYP	MAX	UNIT		
V_{OHA}	Port A output high voltage	$I_{OH}=-20\mu A$ $V_{IB} \geq V_{CCB}-0.4V$	1.1~3.6	1.65~5.5	$V_{CCA} \times 0.67$			V		
V_{OLA}	Port A output low voltage	$I_{OL}=1mA$ $V_{IB} \leq 0.15V$						0.4	V	
V_{OHB}	Port B output high voltage	$I_{OH}=-20\mu A$ $V_{IA} \geq V_{CCA}-0.2V$					$V_{CCB} \times 0.67$		V	
V_{OLB}	Port B output low voltage	$I_{OL}=1mA$ $V_{IA} \leq 0.15V$						0.4	V	
I_I	OE input leakage current	$V_I=V_{CCI}$ or GND, $T_A=25^\circ\text{C}$					-1		1	μA
		$V_I=V_{CCI}$ or GND, $T_A=-40^\circ\text{C}$ to 85°C					-2		2	μA
I_{OZ}	A or B port output current	OE= V_{IL} , $V_I=GND$, $T_A=-40^\circ\text{C}$ to 85°C					-2		2	μA
		OE= V_{IL} , $V_I=V_{CCI}$, $T_A=-40^\circ\text{C}$ to 85°C					-1		1	μA
I_{CCA}	VCCA supply current	OE= V_{IH} $V_I=V_O=Open$, $I_O=0$, $T_A=25^\circ\text{C}$	1.1~3.6	1.65~5.5			1	μA		
			3.6	0			1	μA		
			0	5.5			-1	μA		
		OE= V_{IH} $V_I=V_O=Open$, $I_O=0$, $T_A=85^\circ\text{C}$	3.6	5.5		0.04		μA		
			3.6	0		0.03		μA		
		0	5.5		-0.03		μA			
I_{CCB}	VCCB supply current	OE= V_{IH} $V_I=V_O=Open$, $I_O=0$, $T_A=25^\circ\text{C}$	1.1~3.6	1.65~5.5			16	μA		
			3.6	0			-1	μA		
			0	5.5			1	μA		
		OE= V_{IH} $V_I=V_O=Open$, $I_O=0$, $T_A=85^\circ\text{C}$	3.6	5.5		4.3		μA		
			3.6	0		-0.01		μA		
		0	5.5		0.09		μA			
$I_{CCB}+I_{CCA}$	Combined supply current	$V_I=V_O=Open$ $I_O=0$	1.1~3.6	1.65~5.5			18	μA		
R_{PU}	Resistor pull-up value	$T_A=25^\circ\text{C}$	1.1~3.6	1.65~5.5	8	10	12	k Ω		
R_{NPASS}	The resistor of NMOSFET between A port and B port	OE= V_{IH} , $V_I=0.15V$ $I_{source}=10mA$, $T_A=25^\circ\text{C}$	1.8	3.3		25		Ω		

Timing Requirements (NOTE1)Output load: $C_L=15\text{pF}$, push-pull driver, and $T_A=-40^\circ\text{C}$ to 85°C .

PARAMETER		TEST CONDITION	MIN	MAX	UNIT
$V_{CCA}=1.1\text{V}\pm 0.15\text{V} / 2.5\text{V}\pm 0.2\text{V} / 3.3\text{V}\pm 0.3\text{V}$					
Data Rate		$V_{CCB}=1.8\text{V}\pm 0.2\text{V}$		21	Mbps
		$V_{CCB}=3.3\text{V}\pm 0.3\text{V}$		24	
		$V_{CCB}=5\text{V}\pm 0.5\text{V}$		24	
t_w	Pulse Duration	$V_{CCB}=2.5\text{V}\pm 0.2\text{V}$	45		ns
		$V_{CCB}=3.3\text{V}\pm 0.3\text{V}$	40		
		$V_{CCB}=5\text{V}\pm 0.5\text{V}$	40		

NOTE1: The parameter's variation is guaranteed by design, not production tested.

Switch CharacteristicsOutput load: $C_L=15\text{pF}$, $T_A=25^\circ\text{C}$ for typical values (unless otherwise noted), $V_{CCA}=1.1\text{V}$

PARAMETER	TEST CONDITION		$V_{CCB}=1.65\text{V}$	$V_{CCB}=3.3\text{V}$	$V_{CCB}=5\text{V}$	UNIT
			TYP	TYP	TYP	
t_{PHL} (NOTE2)	A to B	Push-pull	12	17.9	23.5	ns
		Open-drain	8.6	13.5	18.8	
t_{PLH} (NOTE2)	A to B	Push-pull	18.8	15.7	15.2	ns
		Open-drain	27.3	26.4	19.4	
t_{PHL} (NOTE2)	B to A	Push-pull	3.6	3.2	2.8	ns
		Open-drain	4.7	3.5	3.7	
t_{PLH} (NOTE2)	B to A	Push-pull	8.7	2.7	1.8	ns
		Open-drain	0.5	0.8	0.8	
t_{en} Enable time	OE to A or B		31	14.8	12.8	ns
t_{dis} disable time	OE to A or B		139.8	161	97	ns
t_{rA} output rise time	A port rise time	Push-pull	24.3	15.3	8.9	ns
		Open-drain	162.4	106.3	76.2	
t_{rB} output rise time	B port rise time	Push-pull	35.6	24.2	17.1	ns
		Open-drain	141.2	65.5	30.9	
t_{fA} output fall time	A port fall time	Push-pull	6.4	5.3	3.1	ns
		Open-drain	5.6	4.6	4.2	
t_{fB} output fall time	B port fall time	Push-pull	15	25.8	37.5	ns
		Open-drain	12.3	21.8	31.4	
t_{SK} Skew time output	Channel to channel skew		4.9	4.7	4.3	ns

Output load: $C_L=15\text{pF}$, $T_A=25^\circ\text{C}$ for typical values (unless otherwise noted), $V_{CCA}=1.8\text{V}$.

PARAMETER	TEST CONDITION		$V_{CCB}=1.8\text{V}$	$V_{CCB}=3.3\text{V}$	$V_{CCB}=5\text{V}$	UNIT
			TYP	TYP	TYP	
t_{PHL} (NOTE2)	A to B	Push-pull	1.4	2.3	3.2	ns
		Open-drain	3.6	4	4.7	
t_{PLH} (NOTE2)	A to B	Push-pull	2.1	3.2	3.3	ns
		Open-drain	0.1	0.2	0.3	
t_{PHL} (NOTE2)	B to A	Push-pull	3.1	2.3	1.8	ns
		Open-drain	2.4	1.9	2	

PARAMETER	TEST CONDITION		V _{CCB} =1.8V	V _{CCB} =3.3V	V _{CCB} =5V	UNIT
			TYP	TYP	TYP	
t _{PLH} (NOTE2)	B to A	Push-pull	4	2.3	1.7	ns
		Open-drain	-0.19	-0.28	-0.38	
t _{en} Enable time	OE to A or B		21	10.7	7.2	ns
t _{dis} disable time	OE to A or B		138	152.7	156.5	ns
t _{rA} output rise time	A port rise time	Push-pull	10.2	4.5	4.1	ns
		Open-drain	118.4	77.3	56.2	
t _{rB} output rise time	B port rise time	Push-pull	8.2	5.6	4.7	ns
		Open-drain	125.3	60.3	29.4	
t _{fA} output fall time	A port fall time	Push-pull	5.9	2.5	1.4	ns
		Open-drain	4.5	3.9	3.5	
t _{fB} output fall time	B port fall time	Push-pull	3.7	4.2	5.4	ns
		Open-drain	6.6	6.8	7.7	
t _{SK} Skew time output	Channel to channel skew		0.8	0.7	0.7	ns

Output load: C_L=15pF, T_A=25°C for typical values (unless otherwise noted), V_{CCA}=2.5V

PARAMETER	TEST CONDITION		V _{CCB} =2.5V	V _{CCB} =3.3V	V _{CCB} =5V	UNIT
			TYP	TYP	TYP	
t _{PHL} (NOTE2)	A to B	Push-pull	1.6	1.7	1.9	ns
		Open-drain	1.8	2	2.8	
t _{PLH} (NOTE2)	A to B	Push-pull	1.7	2.2	2.4	ns
		Open-drain	0.1	0.1	0.2	
t _{PHL} (NOTE2)	B to A	Push-pull	2	1.8	1.6	ns
		Open-drain	1	1.3	1.3	
t _{PLH} (NOTE2)	B to A	Push-pull	2.2	1.7	1.4	ns
		Open-drain	-0.1	-0.1	-0.2	
t _{en} Enable time	OE to A or B		11.6	9.1	7.3	ns
t _{dis} disable time	OE to A or B		143.4	152.4	154.9	ns
t _{rA} output rise time	A port rise time	Push-pull	4.4	3.7	2.9	ns
		Open-drain	88.7	74.1	54.5	
t _{rB} output rise time	B port rise time	Push-pull	4.6	4.1	3.6	ns
		Open-drain	91.8	67.1	37.2	
t _{fA} output fall time	A port fall time	Push-pull	2.9	2.6	2.4	ns
		Open-drain	3.8	3.3	2.6	
t _{fB} output fall time	B port fall time	Push-pull	2.7	3.2	3.4	ns
		Open-drain	3.8	4	5.1	
t _{SK} Skew time output	Channel to channel skew		0.8	0.8	0.9	ns

Output load: C_L=15pF, T_A=25°C for typical values (unless otherwise noted), V_{CCA}=3.3V

PARAMETER	TEST CONDITION		V _{CCB} =3.3V	V _{CCB} =5V	UNIT
			TYP	TYP	
t _{PHL} (NOTE2)	A to B	Push-pull	1	1.5	ns
		Open-drain	0.9	1.4	
t _{PLH} (NOTE2)	A to B	Push-pull	1.7	1.8	ns
		Open-drain	0.1	0.2	

PARAMETER	TEST CONDITION		V _{CCB} =3.3V	V _{CCB} =5V	UNIT
			TYP	TYP	
t _{PHL} (NOTE2)	B to A	Push-pull	1.7	1.6	ns
		Open-drain	0.5	1.2	
t _{PLH} (NOTE2)	B to A	Push-pull	1.8	1.4	ns
		Open-drain	0.1	-0.1	
t _{en} Enable time	OE to A or B		7.9	6.9	ns
t _{dis} disable time	OE to A or B		148.1	159.7	ns
t _{rA} output rise time	A port rise time	Push-pull	3.3	2.8	ns
		Open-drain	69.3	51.8	
t _{rB} output rise time	B port rise time	Push-pull	3.7	3.3	ns
		Open-drain	72.6	43.1	
t _{fA} output fall time	A port fall time	Push-pull	2.6	2.4	ns
		Open-drain	3.4	3.1	
t _{fB} output fall time	B port fall time	Push-pull	2.5	2.8	ns
		Open-drain	3.4	3.6	
t _{SK} Skew time output	Channel to channel skew		1.2	1.1	ns

NOTE2: t_{PHL} presents propagation delay from high to low, and t_{PLH} presents propagation delay from low to high.

Typical Characteristics

Test Information

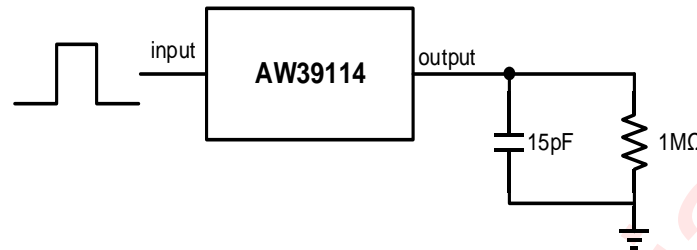

Test Circuit for Date Rate, Pulse Duration, Propagation Delay, Rise Time and Fall Time

Figure 5 Load Circuit of Push-Pull Driver

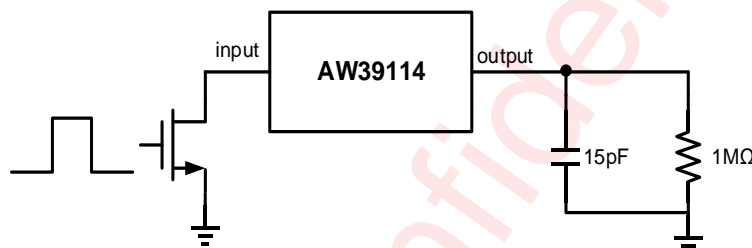

Test Circuit for Date Rate, Pulse Duration, Propagation Delay, Rise Time and Fall Time

Figure 6 Load Circuit of Open-Drain Driver

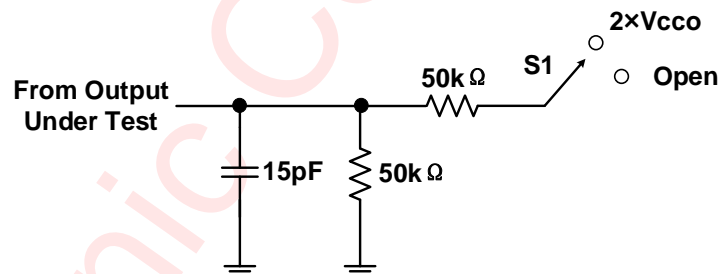

TEST	S1
t_{PZL}/t_{PLZ} (t_{dis})	$2 \times V_{CCO}$
t_{PHZ}/t_{PZH} (t_{en})	Open

1. t_{PLZ} and t_{PHZ} are the same as t_{dis} .
2. t_{PZL} and t_{PZH} are the same as t_{en} .
3. V_{CCI} is the VCC associated with the input port.
4. V_{CCO} is the VCC associated with the output port.
5. The resistance and Capacitance values at output notes above are the total effective values.

Figure 7 Load Circuit for Enable-Time and Disable-Time Measurement

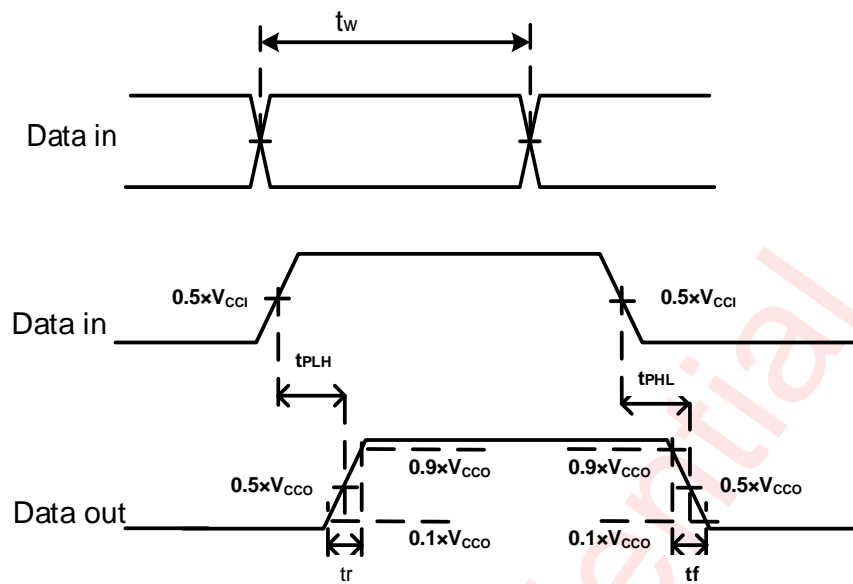

The input pulses should have the following characteristics:

1. $f_{IN} \leq 10\text{MHz}$.
2. $dv/dt \geq 1\text{V/ns}$.

Figure 8 Timing Parameter Definition

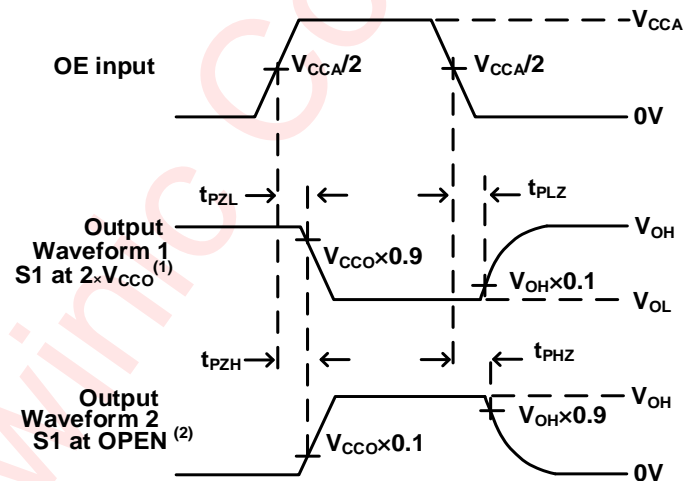

(1) The Waveform 1 is obtained under the condition that the input is low and S1 at $2 \times V_{CCO}$.

(2) The Waveform 2 is obtained under the condition that the input and S1 at OPEN.

Figure 9 Enable and Disable Times

Typical Curve $T_A=25^{\circ}\text{C}$

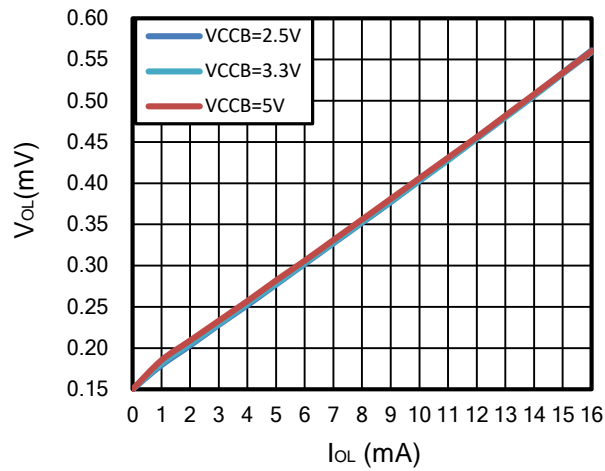

$V_{CCA}=1.8\text{V}$, $OE=1$, $V_{ILA}=0.15\text{V}$

Figure 10 Low-Level Output Voltage vs Low-Level Current

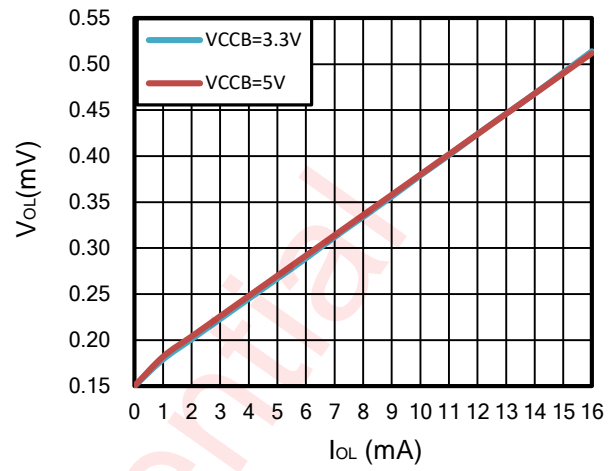

$V_{CCA}=3.3\text{V}$, $OE=1$, $V_{ILA}=0.15\text{V}$

Figure 11 Low-Level Output Voltage vs Low-Level Current

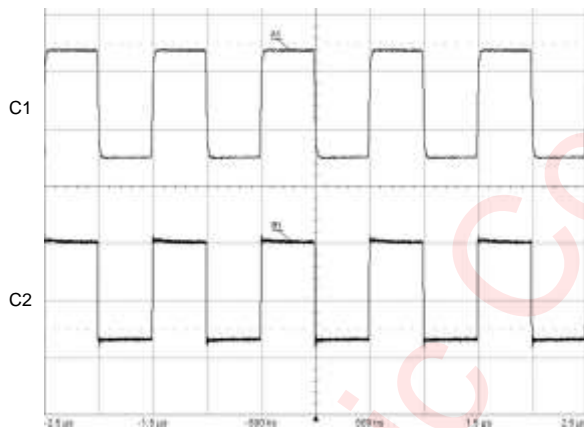

C1: 1.00V/div C2: 2.00V/div

$V_{CCA}=1.8\text{V}$, $V_{CCB}=3.3\text{V}$, $OE=1$, Push-Pull Driver
Signal is translated from A port to B port

Figure 12 Level Translation of a 1MHz Signal

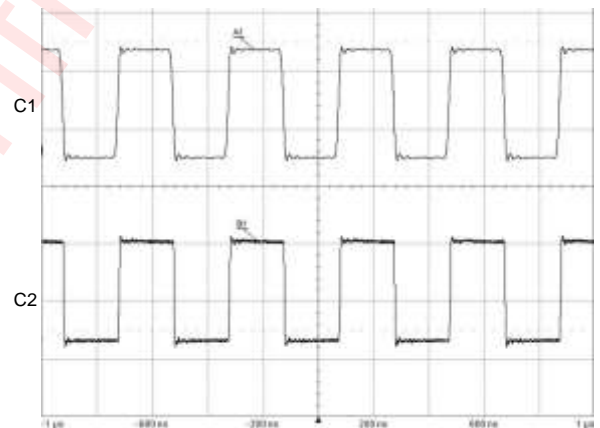

C1: 1.00V/div C2: 2.00V/div

$V_{CCA}=1.8\text{V}$, $V_{CCB}=3.3\text{V}$, $OE=1$, Push-Pull Driver
Signal is translated from A port to B port

Figure 13 Level Translation of a 2.5MHz Signal

Detailed Functional Description

AW39114 is a 4-bit high-performance voltage-level translator without direction control signal, which is a non-inverting converter and can be used to convert digital signal with mixed-voltage systems. Port A can support I/O voltages from 1.1 V to 3.6 V, while Port B is able to support I/O voltage range from 1.65 V to 5.5 V. The chip uses a transmission gate architecture with an rising edge rate accelerator (one-shot), to increase overall data rate. Also, 10k Ω pull-up resistors are integrated in the chip, which ensures the chip not only supports push-pull applications but also can be used in open-drain applications directly.

One-shot Accelerator

The One-Shot rising edge accelerator circuit speeds up the rising edge to help increasing the chip's data rate. Once the chip has detected the rising edge of the input signal from low to high, the one-shot circuit generates a pulse signal of approximately 30ns, which enables the internal pull-up PMOS transistor between power supply and output, thereby accelerating the output port from low to high. During this acceleration phase, the output resistance of the driver is reduced from 10k Ω to approximately 60 Ω . While detecting the output has been turned up, the one-shot pulse signal is finished and pull-up PMOS transistor is quickly turned off. This architecture reduces the average dynamic power consumption of the chip while allowing it to meet different drive requirements.

Gate Bias

For the bidirectional voltage translator AW39114, a NMOS switch transistor is used between the input and output. When translating high level, the NMOS transistor is turned off, and the input and output terminals are isolated so that they do not impact each other. When the low level is translated, the NMOS switch transistor is fully turned on, so that the output terminal can be quickly pulled down to the low voltage level. Therefore, the gate bias voltage of the NMOS switch transistor is set to a fixed value about $V_{CCA} + V_{TH}$. It is also because of this architecture that $V_{CCA} \leq V_{CCB}$ needs to be guaranteed in the applications.

Enable Control

The AW39114's OE pin can disable the chip by setting OE to low voltage level, allowing all I/O to be pulled to the supply voltage through a 5M Ω internal pull-up resistor. The disable time (t_{dis}) represents the delay time from OE going low to the chip turns to OFF-state. And the enable time (t_{en}) indicates the delay from OE going high to the chip working in translation state. Meanwhile, OE is recommended to be tied to GND through an external pull-down resistor to ensure the ultra-low power-supply quiescent current. The minimum value of the resistor is determined by the current-sourcing capability of the driver.

Input Driver

The rising edge time of the signal (t_{rA} , t_{rB}) and propagation delay from low to high (t_{PLH}) are determined by the rising edge rate of the input signal, the ONE-SHOT accelerator's pull-up capability, and the capacitive load of the port. The falling edge time of the signal (t_{fA} , t_{fB}) depends on the falling edge rate of the input signal, the output impedance of the external driver, and the capacitive load on the data line. Similarly, t_{PHL} and the maximum data rate also depend on the output impedance of the external driver. So, the test conditions for t_{rA} , t_{rB} , t_{fA} , t_{fB} , t_{PLH} , t_{PHL} and maximum data rate in the data sheet are that the output impedance of the external driver is less than 50 Ω .

Output Load

It is recommended that a PCB layout with short PCB layout length:

1. Avoid excessive capacitive load triggers ONE-SHOT circuit falsely;
2. It can ensure that the round trip delay of any reflection is less than a single ONE-SHOT duration;
3. Improve signal integrity.

Meanwhile, the pulse width of the ONE-SHOT circuit is approximately 30 ns, which determines the maximum output load capacitance that the chip can drive. For very heavy output capacitive loads, the one-shot accelerator will time-out before the output is fully pulled to high level, at which case the signal transmission will be distorted. So the ONE-SHOT duration design requires a trade-off between dynamic power consumption, capacitive load driving capability and maximum data rate. The signal t_w at the maximum translation rate should be greater than the maximum pulse width of the ONE-SHOT circuit, and the delay caused by the output capacitive load should be less than the maximum pulse width of the ONE-SHOT circuit.

awinic Confidential

Application Information

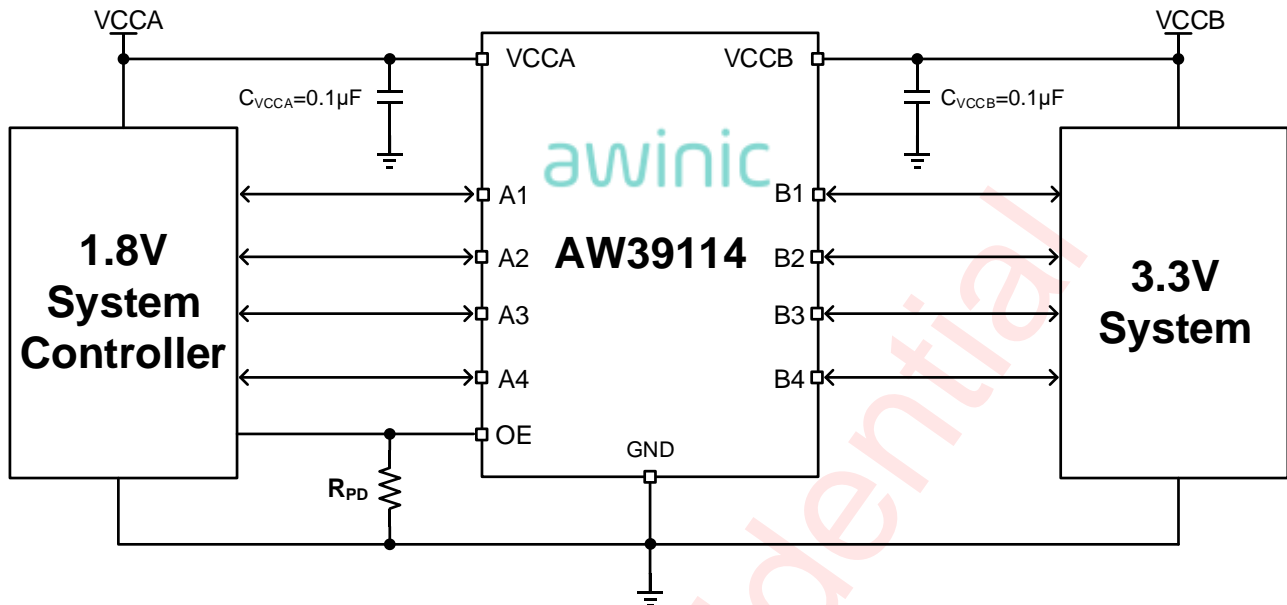

Figure 14 AW39114 Application Circuit

AW39114 is a 4-bit voltage-level translator without direction control signal, which is suitable for interfacing devices or systems operating at different interface voltages with one another. Port A can support I/O voltages from 1.1 V to 3.6 V, while Port B is able to support I/O voltage range from 1.65 V to 5.5 V. Also, 10kΩ pull-up resistors are integrated in the chip, which ensures the chip not only supports push-pull applications but also can be used in open-drain applications directly.

VCC Capacitor Selection

The device is a 4-bit high-performance voltage-level translator that requires adequate power supply decoupling. Place a low equivalent-series-resistance (ESR) ceramic capacitor, recommend 0.1µF or larger than 0.1µF.

R_{PD} Selection

Drive OE pin HIGH to enable the device. If the voltage level of OE pin is low, all I/O are pulled to the supply voltage through a 5MΩ internal pull-up resistor. OE is recommended to be tied to GND through an external pull-down resistor to ensure the ultra-low power-supply quiescent current. OE pin is high impedance without internal pull down resistor, customer can choose the resistor value based on the source drive capability and current consumption.

PCB Layout Consideration

1. Maintain the integrity of the ground plane and avoid being divided by routing signal lines or power lines on the complete ground plane.
2. The input capacitor of the power supply should be close to the pin of the chip to achieve the best filtering effect. The distance between the input capacitor and the pin of the chip is recommended not to exceed 3mm.
3. In order to maintain the integrity of the transmission signal, the length of the signal transmission line should be as short as possible, parallel routing should be avoided when the signal transmission line is routed across layers, and the input and output paths of the signal should be as symmetrical as possible.

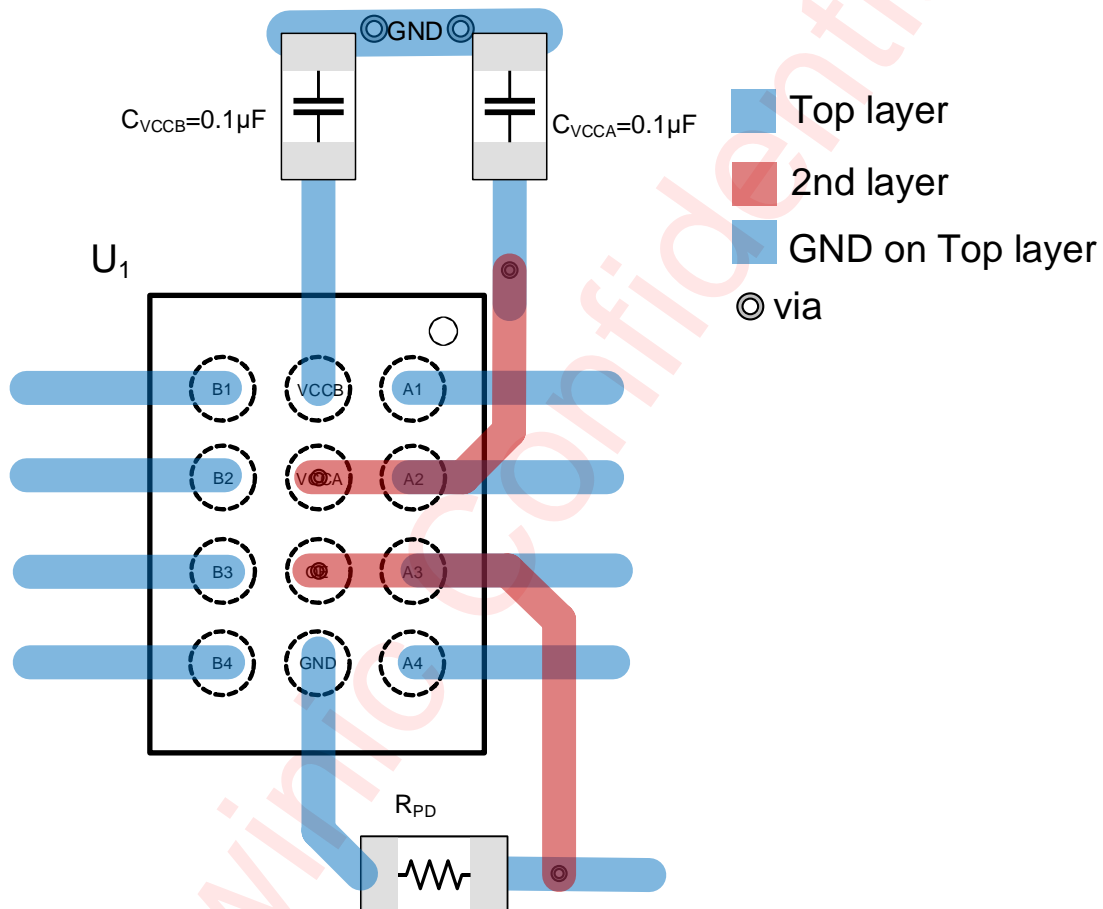
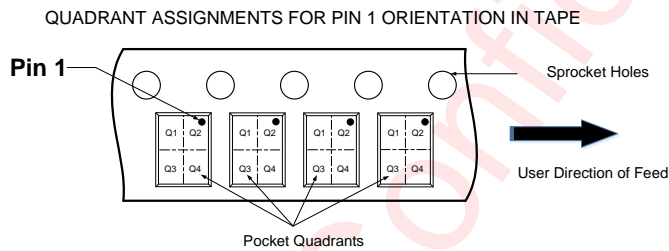
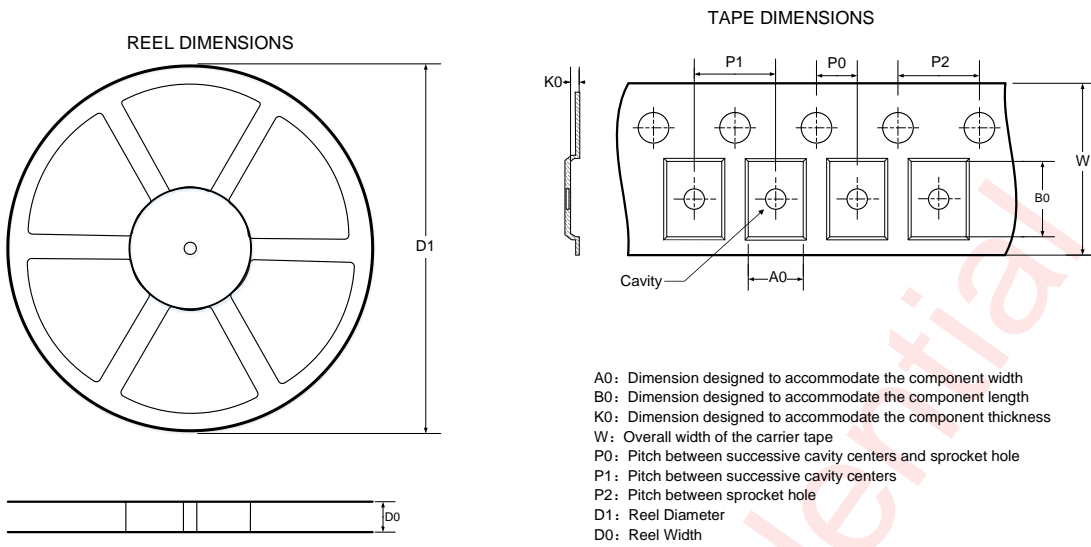

Figure 15 AW39114FOR Layout Example

Tape And Reel Information



Note: The above picture is for reference only. Please refer to the value in the table below for the actual size

DIMENSIONS AND PIN1 ORIENTATION

D1 (mm)	D0 (mm)	A0 (mm)	B0 (mm)	K0 (mm)	P0 (mm)	P1 (mm)	P2 (mm)	W (mm)	Pin1 Quadrant
179.00	9.20	1.49	1.99	0.75	2.00	4.00	4.00	8.00	Q2

All dimensions are nominal

Package Description

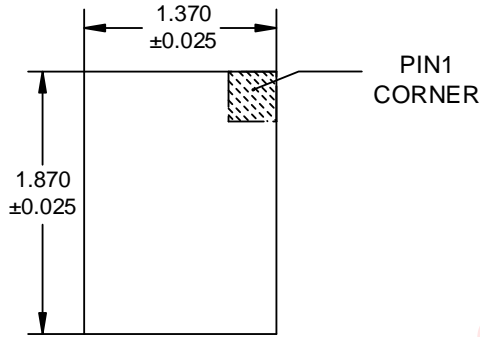

Top View

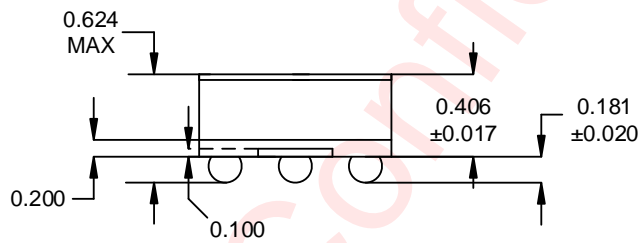

Side View

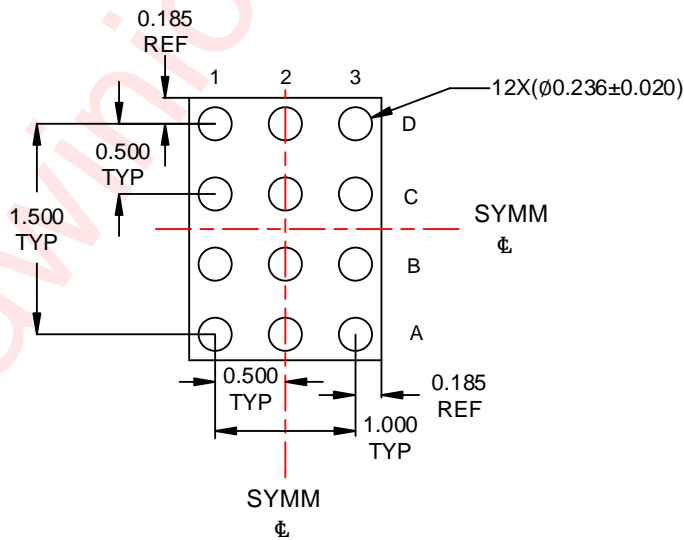

Bottom View

Unit: mm

Land Pattern Data

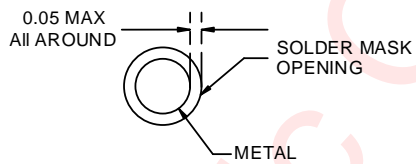
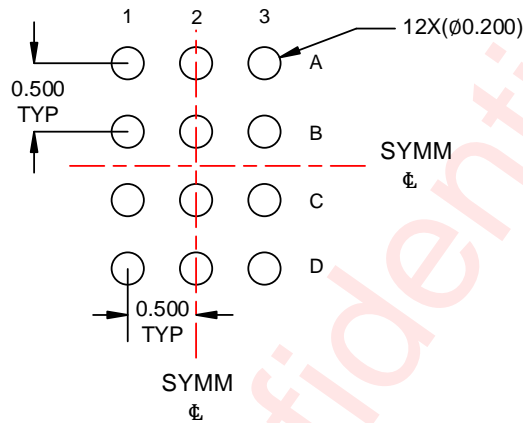

NON-SOLDER MASK DEFINED

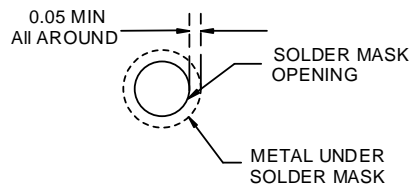

SOLDER MASK DEFINED

Unit: mm

Revision History

Version	Date	Change Record
V1.0	Feb. 2021	Official Released
V1.1	Dec.2021	<ol style="list-style-type: none">1. Modified the position of numbers in Figure(Page 2)2. Added I_{IK} and I_{OK} in Absolute Maximum Ratings(Page 5)3. Modified the test condition of R_{NPASS}(Page 7)4. Added the I_{CCA} and I_{CCB} value at 85°C(Page 7)
V1.2	Apr.2022	<ol style="list-style-type: none">1. Changed the value of V_{IH} for A port (Page 7)2. Modified some formats (Page 18)
V1.3	Jul.2022	<ol style="list-style-type: none">1. Modified some formats2. Added PCB layout consideration (Page17)

awinic Confidential

Disclaimer

Information in this document is believed to be accurate and reliable. However, Shanghai AWINIC Technology Co., Ltd (AWINIC Technology) does not give any representations or warranties, expressed or implied, as to the accuracy or completeness of such information and shall have no liability for the consequences of use of such information.

AWINIC Technology reserves the right to make changes to information published in this document, including without limitation specifications and product descriptions, at any time and without notice. Customers shall obtain the latest relevant information before placing orders and shall verify that such information is current and complete. This document supersedes and replaces all information supplied prior to the publication hereof.

AWINIC Technology products are not designed, authorized or warranted to be suitable for use in medical, military, aircraft, space or life support equipment, nor in applications where failure or malfunction of an AWINIC Technology product can reasonably be expected to result in personal injury, death or severe property or environmental damage. AWINIC Technology accepts no liability for inclusion and/or use of AWINIC Technology products in such equipment or applications and therefore such inclusion and/or use is at the customer's own risk.

Applications that are described herein for any of these products are for illustrative purposes only. AWINIC Technology makes no representation or warranty that such applications will be suitable for the specified use without further testing or modification.

All products are sold subject to the general terms and conditions of commercial sale supplied at the time of order acknowledgement.

Nothing in this document may be interpreted or construed as an offer to sell products that is open for acceptance or the grant, conveyance or implication of any license under any copyrights, patents or other industrial or intellectual property rights.

Reproduction of AWINIC information in AWINIC data books or data sheets is permissible only if reproduction is without alteration and is accompanied by all associated warranties, conditions, limitations, and notices. AWINIC is not responsible or liable for such altered documentation. Information of third parties may be subject to additional restrictions.

Resale of AWINIC components or services with statements different from or beyond the parameters stated by AWINIC for that component or service voids all express and any implied warranties for the associated AWINIC component or service and is an unfair and deceptive business practice. AWINIC is not responsible or liable for any such statements.