

CUSTOMER

REV.	ECN NO.	DESCRIPTION	DATE	DESIGN

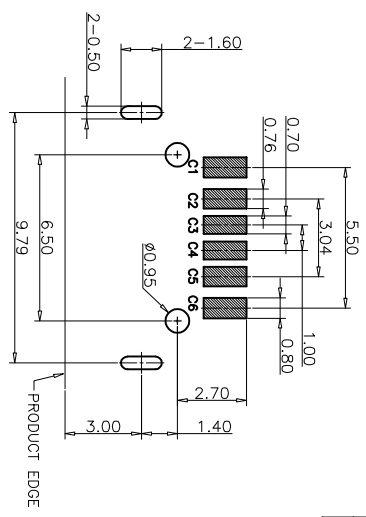

RECOMMEND P.C.B LAYOUT(COMPONENT SIDE)
TOLERANCE FOR PCB LAYOUT IS ±0.05

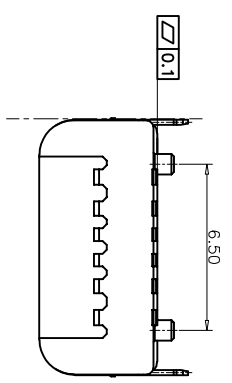
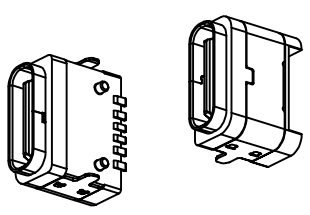
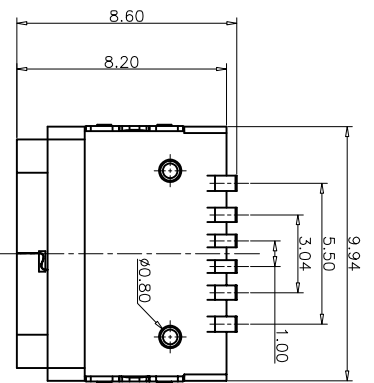
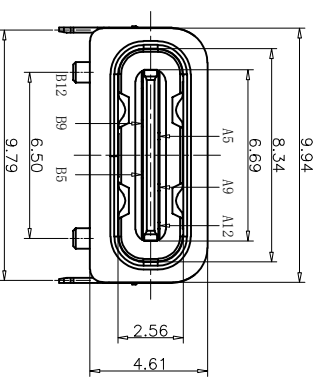
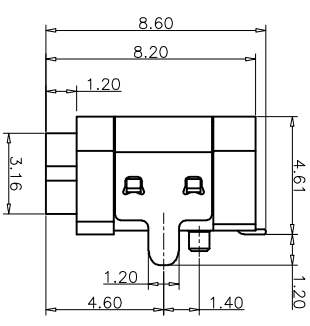
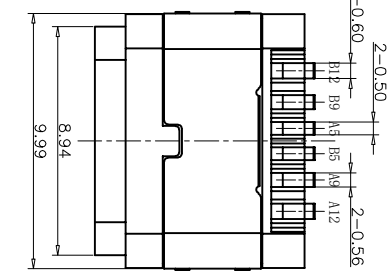

- NOTES:
SPECIFICATION:
1. CURRENT RATING: 3.0A MAX
2. VOLTAGE: 100 VAC
3. TEMPERATURE RANGE: -30°C~+85°C
4. CONTACT RESISTANCE: 40 MILLIONHM MAX
5. INSULATION RESISTANCE: 100 MEGOHMS MIN
6. INSERTION FORCE: 5N~20N
7. UNMATING FORCE: 8N~20N
8. DURABILITY: 10000 CYCLES
9. WATER PROOFNESS: THIS PRODUCT IS BASED ON IPX7.

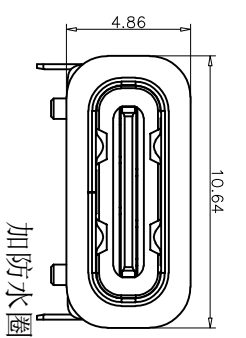

加防水圈示意图

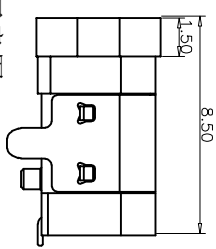

TABLE:

NO	PART	QTY	Material
1	SHELL	1	STAINLESS STEEL,NI PLATED
2	CONTACT	6	COPPER STEEL,TIN/AU/NI PLATED
3	IND PLATE	1	STAINLESS STEEL,NO PLATING
4	IND HOUSING	1	HIGH TEMPERATURE RESISTANT PLASTIC BLACK UL94 V-0
5	2ND HOUSING	1	HIGH TEMPERATURE RESISTANT PLASTIC BLACK UL94 V-0
6	SHIELDING PLATE	1	STAINLESS STEEL,NI PLATED

PIN ASSIGNMENT:

PIN NO	A1&B12	A4&B9	A5	B5	A9&B4	A12&B1
SIGNAL NAME	GND	VBUS	CC1	CC2	VBUS	GND
PCB PAD NO.	C1	C2	C3	C4	C5	C6

TOLERANCE		NAME(INTENDED USE)	
X.X ±0.30	X.X' ±10'	CUSTOMER DRAWING	
XX ±0.20	X.X' ± 8'	DRAWG NO. FY23-011TC61F182-62	
.XXX ±0.10	.XX' ± 5'	TITLE: CF 6P防水六级板上两脚8.2L	
UNITS	mm	DESIGN: ZXM	
MATERILA	---	CHED: ---	
FINISH	---	APPD: ---	

FYFOU 广东富盈兴业精密科技实业有限公司
Guangdong FYFOU Precision Electronic Technology Co.,Ltd.

SCALE SHEET REV. 1:1 1/2 A