

TIBPAL22V10C, TIBPAL22V10AC, TIBPAL22V10AM HIGH-PERFORMANCE *IMPACT*™ PROGRAMMABLE ARRAY LOGIC CIRCUITS

SRPS024A – OCTOBER 1986 – REVISED APRIL 2010

- **Second-Generation PLD Architecture**
- **Choice of Operating Speeds**
 TIBPAL22V10AC . . . 25 ns Max
 TIBPAL22V10AM . . . 30 ns Max
 TIBPAL22V10C . . . 35 ns Max
- **Increased Logic Power – Up to 22 Inputs and 10 Outputs**
- **Increased Product Terms – Average of 12 Per Output**
- **Variable Product Term Distribution Allows More Complex Functions to Be Implemented**
- **Each Output Is User Programmable for Registered or Combinational Operation, Polarity, and Output Enable Control**
- **TTL-Level Preload for Improved Testability**
- **Extra Terms Provide Logical Synchronous Set and Asynchronous Reset Capability**
- **Fast Programming, High Programming Yield, and Unsurpassed Reliability Ensured Using Ti-W Fuses**
- **AC and DC Testing Done at the Factory Utilizing Special Designed-In Test Features**
- **Dependable Texas Instruments Quality and Reliability**
- **Package Options Include Both Plastic and Ceramic Chip Carriers in Addition to Plastic and Ceramic DIPs**
- **Functionally Equivalent to AMDs AMPAL22V10 and AMPAL22V10A**

C SUFFIX . . . NT PACKAGE
M SUFFIX . . . JT OR W PACKAGE
(TOP VIEW)

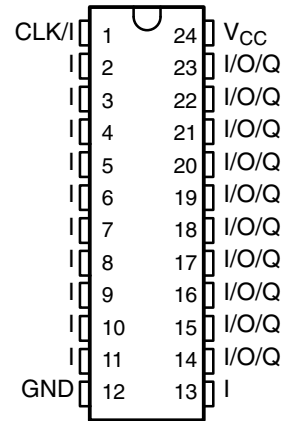

C SUFFIX . . . FN PACKAGE
M SUFFIX . . . FK PACKAGE
(TOP VIEW)

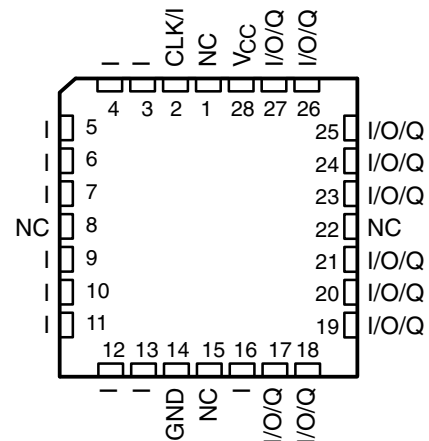

NC – No internal connection
 Pin assignments in operating mode

description

The TIBPAL22V10 and TIBPAL22V10A are programmable array logic devices featuring high speed and functional equivalency when compared to presently available devices. They are implemented with the familiar sum-of-products (AND-OR) logic structure featuring the new concept "Programmable Output Logic Macrocell". These *IMPACT*™ circuits combine the latest Advanced Low-Power Schottky technology with proven titanium-tungsten fuses to provide reliable, high-performance substitutes for conventional TTL logic.

These devices contain up to 22 inputs and 10 outputs. They incorporate the unique capability of defining and programming the architecture of each output on an individual basis. Outputs may be registered or nonregistered and inverting or noninverting as shown in the output logic macrocell diagram. The ten potential outputs are enabled through the use of individual product terms.

These devices are covered by U.S. Patent 4,410,987.
IMPACT is a trademark of Texas Instruments Incorporated.

PRODUCTION DATA information is current as of publication date.
 Products conform to specifications per the terms of Texas Instruments
 standard warranty. Production processing does not necessarily include
 testing of all parameters.



POST OFFICE BOX 655303 • DALLAS, TEXAS 75265

Copyright © 2010, Texas Instruments Incorporated

TIBPAL22V10C, TIBPAL22V10AC, TIBPAL22V10AM HIGH-PERFORMANCE *IMPACT*™ PROGRAMMABLE ARRAY LOGIC CIRCUITS

SRPS024A – OCTOBER 1986 – REVISED APRIL 2010

description (continued)

Further advantages can be seen in the introduction of variable product term distribution. This technique allocates from 8 to 16 logical product terms to each output for an average of 12 product terms per output. This variable allocation of terms allows far more complex functions to be implemented than in previously available devices.

Circuit design is enhanced by the addition of a synchronous set and an asynchronous reset product term. These functions are common to all registers. When the synchronous set product term is a logic 1, the output registers are loaded with a logic 1 on the next low-to-high clock transition. When the asynchronous reset product term is a logic 1, the output registers are loaded with a logic 0. The output logic level after set or reset depends on the polarity selected during programming. Output registers can be preloaded to any desired state during testing. Preloading permits full logical verification during product testing.

With features such as programmable output logic macrocells and variable product term distribution, the TIBPAL22V10 and TIBPAL22V10A offer quick design and development of custom LSI functions with complexities of 500 to 800 equivalent gates. Since each of the ten output pins may be individually configured as inputs on either a temporary or permanent basis, functions requiring up to 21 inputs and a single output or down to 12 inputs and 10 outputs are possible.

A power-up clear function is supplied that forces all registered outputs to a predetermined state after power is applied to the device. Registered outputs selected as active-low power up with their outputs high. Registered outputs selected as active-high power up with their outputs low.

A single security fuse is provided on each device to discourage unauthorized copying of fuse patterns. Once blown, the verification circuitry is disabled and all other fuses will appear to be open.

The TIBPAL22V10C and TIBPAL22V10AC are characterized for operation from 0°C to 75°C. The TIBPAL22V10AM is characterized for operation over the full military temperature range of –55°C to 125°C.



POST OFFICE BOX 655303 • DALLAS, TEXAS 75265

TIBPAL22V10C, TIBPAL22V10AC, TIBPAL22V10AM HIGH-PERFORMANCE *IMPACT*™ PROGRAMMABLE ARRAY LOGIC CIRCUITS

SRPS024A – OCTOBER 1986 – REVISED APRIL 2010

functional block diagram (positive logic)

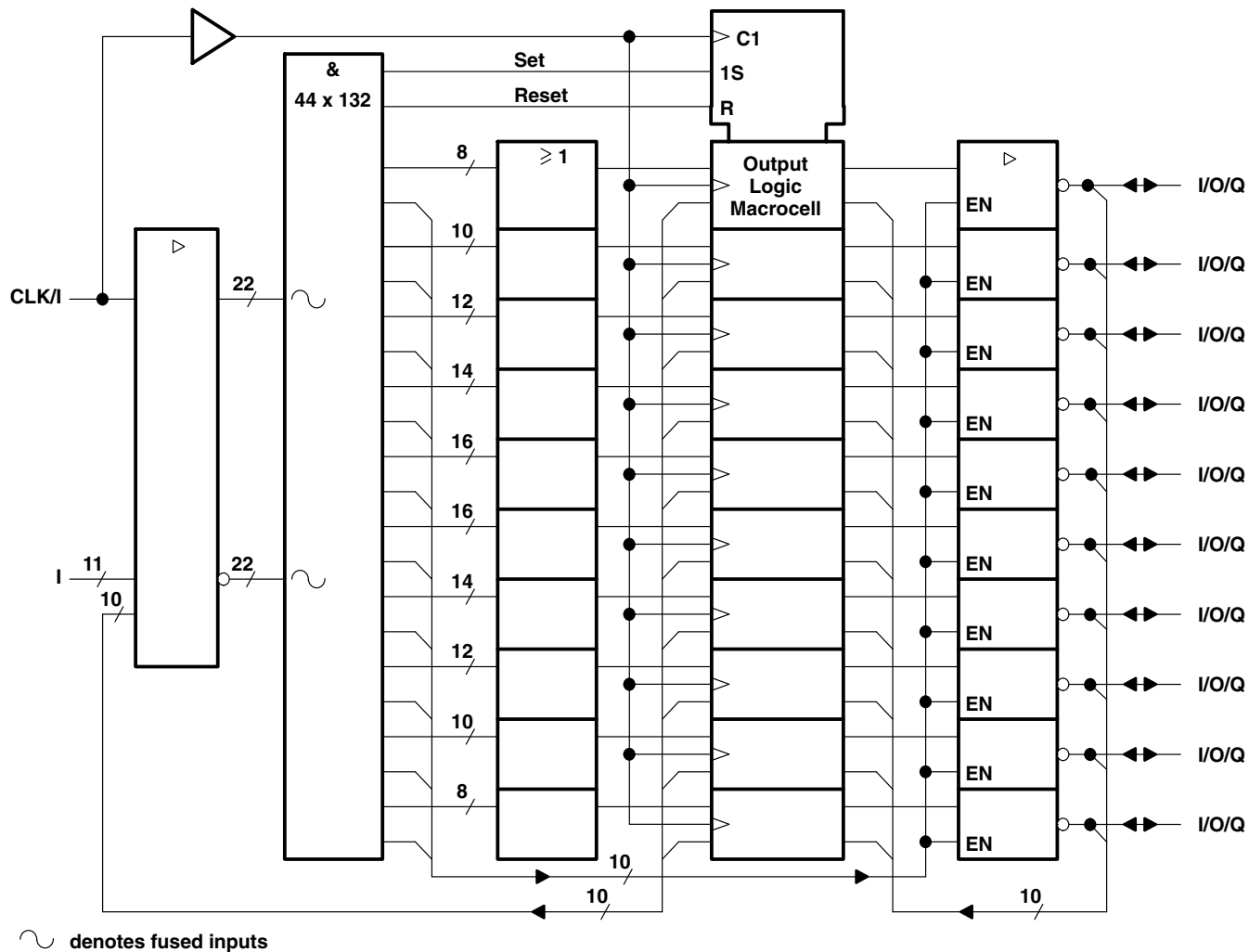

TIBPAL22V10C, TIBPAL22V10AC, TIBPAL22V10AM HIGH-PERFORMANCE *IMPACT*™ PROGRAMMABLE ARRAY LOGIC CIRCUITS

SRPS024A – OCTOBER 1986 – REVISED APRIL 2010

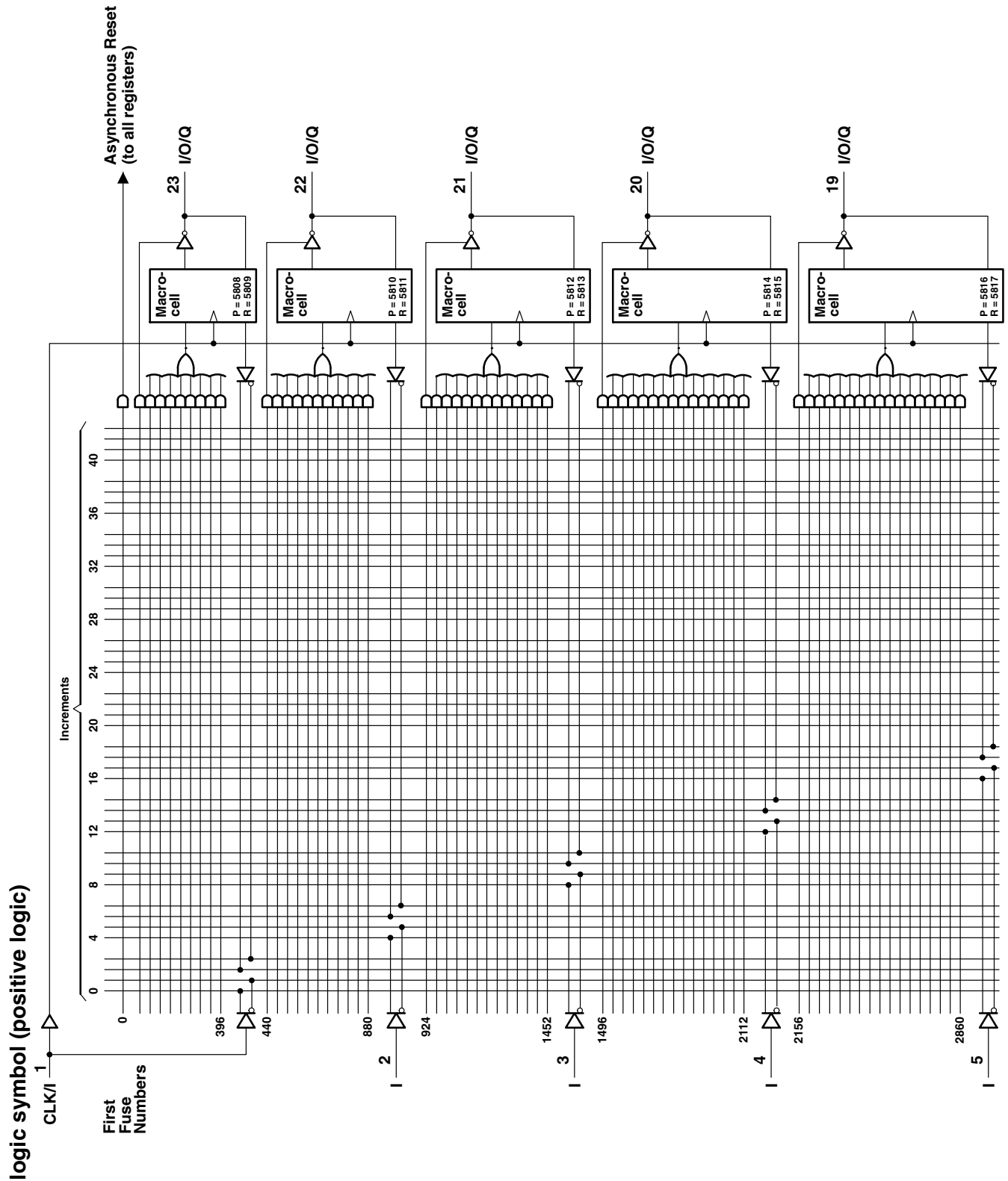

TIBPAL22V10C, TIBPAL22V10AC, TIBPAL22V10AM HIGH-PERFORMANCE *IMPACT*™ PROGRAMMABLE ARRAY LOGIC CIRCUITS

SRPS024A – OCTOBER 1986 – REVISED APRIL 2010

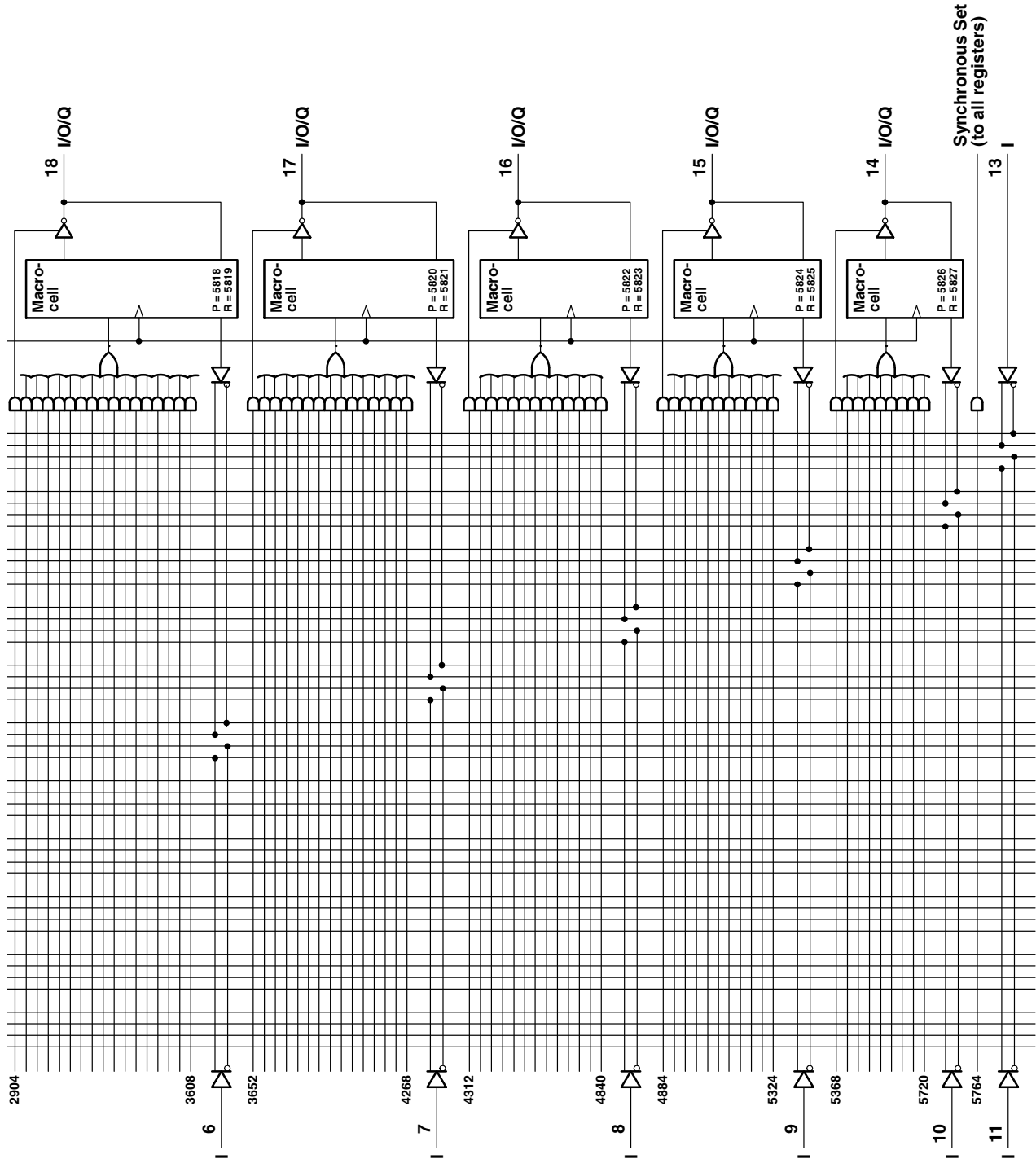

Fuse number = First fuse number + Increment
 Inside each MACROCELL the "P" fuse is the polarity fuse and the "R" fuse is the register fuse.



POST OFFICE BOX 655303 • DALLAS, TEXAS 75265

TIBPAL22V10C, TIBPAL22V10AC, TIBPAL22V10AM HIGH-PERFORMANCE *IMPACT*™ PROGRAMMABLE ARRAY LOGIC CIRCUITS

SRPS024A – OCTOBER 1986 – REVISED APRIL 2010

output logic macrocell diagram

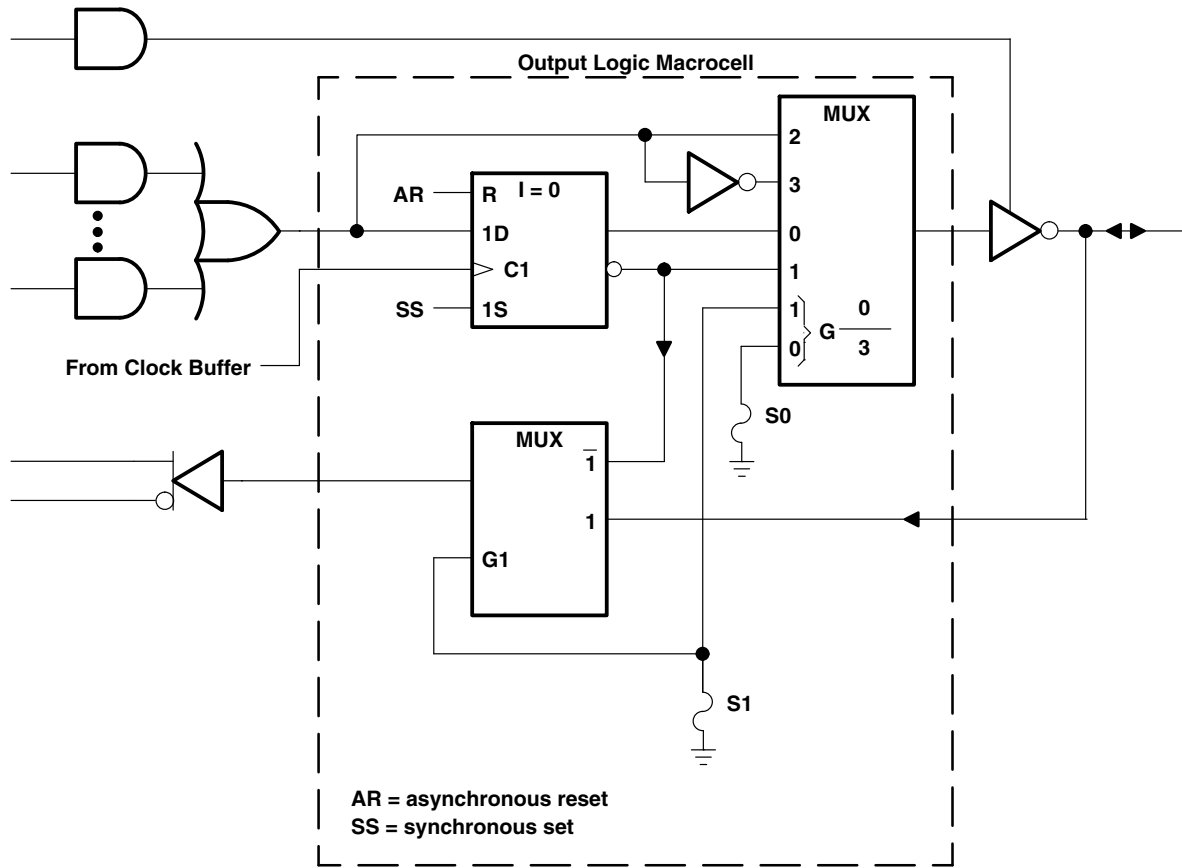

TIBPAL22V10C, TIBPAL22V10AC, TIBPAL22V10AM HIGH-PERFORMANCE *IMPACT*™ PROGRAMMABLE ARRAY LOGIC CIRCUITS

SRPS024A – OCTOBER 1986 – REVISED APRIL 2010

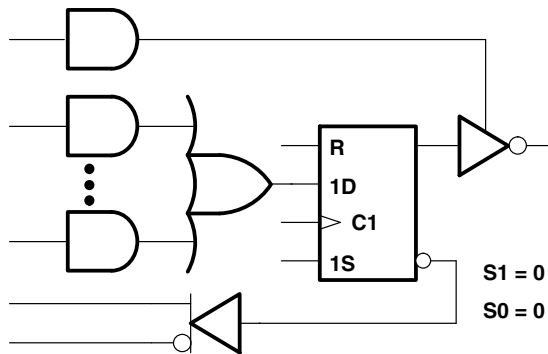

REGISTER FEEDBACK, REGISTERED, ACTIVE-LOW OUTPUT

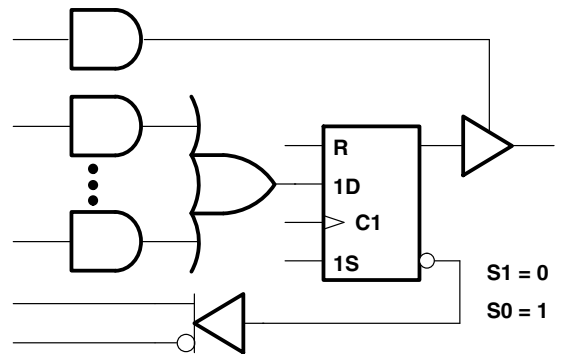

REGISTER FEEDBACK, REGISTERED, ACTIVE-HIGH OUTPUT

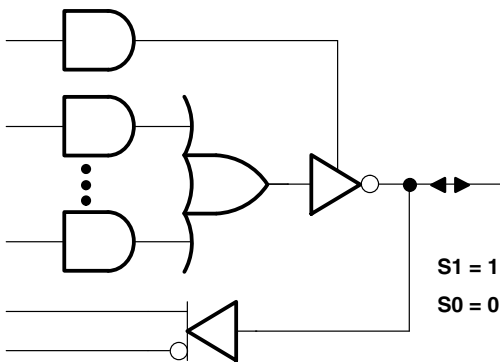

I/O FEEDBACK, COMBINATIONAL, ACTIVE-LOW OUTPUT

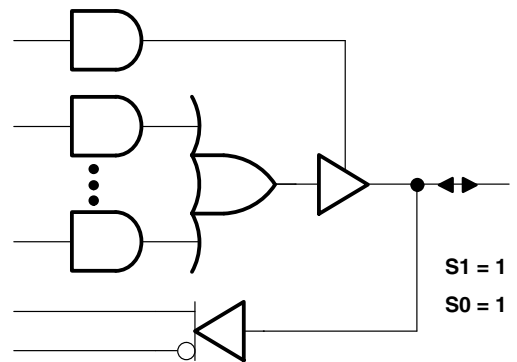

I/O FEEDBACK, COMBINATIONAL, ACTIVE-HIGH OUTPUT

MACROCELL FEEDBACK AND OUTPUT FUNCTION TABLE

FUUSE SELECT		FEEDBACK AND OUTPUT CONFIGURATION		
S1	S0			
0	0	Register feedback	Registered	Active low
0	1	Register feedback	Registered	Active high
1	0	I/O feedback	Combinational	Active low
1	1	I/O feedback	Combinational	Active high

0 = unblown fuse, 1 = blown fuse

S1 and S0 are select-function fuses as shown in the output logic macrocell diagram.

Figure 1. Resultant Macrocell Feedback and Output Logic After Programming

TIBPAL22V10C, TIBPAL22V10AC HIGH-PERFORMANCE *IMPACT*™ PROGRAMMABLE ARRAY LOGIC CIRCUITS

SRPS024A – OCTOBER 1986 – REVISED APRIL 2010

absolute maximum ratings over operating free-air temperature range (unless otherwise noted)

Supply voltage, V_{CC} (see Note 1)	7 V
Input voltage (see Note 1)	-5.5 V
Voltage range applied to disabled output (see Note 1)	5.5 V
Operating free-air temperature range	0°C to 75°C
Storage temperature range	-65°C to 150°C

NOTE 1: These ratings apply except for programming pins during a programming cycle or during a preload cycle.

recommended operating conditions

		TIBPAL22V10C			TIBPAL22V10AC			UNIT
		MIN	NOM	MAX	MIN	NOM	MAX	
V_{CC}	Supply voltage	4.75	5	5.25	4.75	5	5.25	V
V_{IH}	High-level input voltage	2		5.5	2		5.5	V
V_{IL}	Low-level input voltage			0.8			0.8	V
I_{OH}	High-level output current			-3.2			-3.2	mA
I_{OL}	Low-level output current			16			16	mA
f_{clock}	Clock frequency†			18			28.5	MHz
t_w	Pulse duration	Clock high or low		25	15		ns	
		Asynchronous reset high or low		35	25			
t_{su}	Setup time before clock↑	Input		30	20		ns	
		Feedback		30	20			
		Synchronous set		30	25			
		Asynchronous reset low (inactive)		35	25			
t_h	Hold time, input, set, or feedback after clock↑	0			0			ns
T_A	Operating free-air temperature	0			75			°C

$$† f_{clock} \text{ (with feedback)} = \frac{1}{t_{su} + t_{pd}(\text{CLK to Q})}, f_{clock} \text{ (without feedback)} = \frac{1}{t_w(\text{low}) + t_w(\text{high})}$$

TIBPAL22V10C, TIBPAL22V10AC HIGH-PERFORMANCE *IMPACT*™ PROGRAMMABLE ARRAY LOGIC CIRCUITS

SRPS024A – OCTOBER 1986 – REVISED APRIL 2010

electrical characteristics over recommended operating free-air temperature range

PARAMETER	TEST CONDITIONS	TIBPAL22V10C			TIBPAL22V10AC			UNIT
		MIN	TYP†	MAX	MIN	TYP†	MAX	
V _{IK}	V _{CC} = 4.75 V, I _I = -18 mA			-1.2			-1.2	V
V _{OH}	V _{CC} = 4.75 V, I _{OH} = -3.2 mA	2.4	3.5		2.4	3.5		V
V _{OL}	V _{CC} = 4.75 V, I _{OL} = 16 mA		0.35	0.5		0.35	0.5	V
I _{OZH}	V _{CC} = 5.25 V, V _O = 2.7 V			0.1			0.1	mA
I _{IL}	Any output Any I/O V _{CC} = 5.25 V, V _I = 0.4 V			-100			-100	μA
				-250			-250	
I _I	V _{CC} = 5.25 V, V _I = 5.5 V			1			1	mA
I _{IH}	V _{CC} = 5.25 V, V _I = 2.7 V			25			25	μA
I _{IL}	V _{CC} = 5.25 V, V _I = 0.4 V			-0.25			-0.25	mA
I _{OS} ‡	V _{CC} = 5.25 V, V _O = 0.5 V	-30		-90	-30		-90	mA
I _{CC}	V _{CC} = 5.25 V, V _I = GND, Outputs open		120	180		120	180	mA

switching characteristics over recommended ranges of supply voltage and operating free-air temperature (unless otherwise noted)

PARAMETER	FROM (INPUT)	TO (OUTPUT)	TEST CONDITIONS	TIBPAL22V10C			TIBPAL22V10AC			UNIT
				MIN	TYP†	MAX	MIN	TYP†	MAX	
f _{max} ¶	With feedback		R1 = 300 Ω, R2 = 390 Ω, See Figure 4	18			28.5			MHz
t _{pd}	I, I/O	I/O			15	35		15	25	ns
t _{pd}	I, I/O (reset)	Q			15	40		15	30	ns
t _{pd}	CLK	Q			10	25		10	15	ns
t _{en}	I, I/O	I/O, Q			15	35		15	25	ns
t _{dis}	I, I/O	I/O, Q			15	35		15	25	ns

† All typical values are at V_{CC} = 5 V, T_A = 25°C.

‡ Not more than one output should be shorted at a time, and the duration of the short circuit should not exceed one second. V_O is set at 0.5 V to avoid test problems caused by test equipment ground degradation.

$$¶ f_{max} \text{ (with feedback)} = \frac{1}{t_{su} + t_{pd}(\text{CLK to Q})}, f_{max} \text{ (without feedback)} = \frac{1}{t_w(\text{low}) + t_w(\text{high})}$$



TIBPAL22V10AM HIGH-PERFORMANCE *IMPACT*™ PROGRAMMABLE ARRAY LOGIC CIRCUITS

SRPS024A – OCTOBER 1986 – REVISED APRIL 2010

absolute maximum ratings over operating free-air temperature range (unless otherwise noted)

Supply voltage, V_{CC} (see Note 1)	7 V
Input voltage (see Note 1)	-5.5 V
Voltage range applied to disabled output (see Note 1)	5.5 V
Operating free-air temperature range	-55°C to 125°C
Storage temperature range	-65°C to 150°C

NOTE 1: These ratings apply except for programming pins during a programming cycle or during a preload cycle.

recommended operating conditions

		MIN	NOM	MAX	UNIT
V_{CC}	Supply voltage	4.5	5	5.5	V
V_{IH}	High-level input voltage	2		5.5	V
V_{IL}	Low-level input voltage			0.8	V
I_{OH}	High-level output current			-2	mA
I_{OL}	Low-level output current			12	mA
f_{clock}	Clock frequency†			22	MHz
t_w	Pulse duration	Clock high or low		20	ns
		Asynchronous reset high or low		30	
t_{su}	Setup time before clock↑	Input		25	ns
		Feedback		25	
		Synchronous set		25	
		Asynchronous reset low (inactive)		30	
t_h	Hold time, input, set, or feedback after clock↑	0			ns
T_A	Operating free-air temperature	-55		125	°C

$$\dagger f_{clock} \text{ (with feedback)} = \frac{1}{t_{su} + t_{pd}(\text{CLK to Q})}; f_{clock} \text{ (without feedback)} = \frac{1}{t_w(\text{low}) + t_w(\text{high})}$$

TIBPAL22V10AM

HIGH-PERFORMANCE *IMPACT*™ PROGRAMMABLE ARRAY LOGIC CIRCUITS

SRPS024A – OCTOBER 1986 – REVISED APRIL 2010

electrical characteristics over recommended operating free-air temperature range

PARAMETER	TEST CONDITIONS		MIN	TYP†	MAX	UNIT
V _{IK}	V _{CC} = 4.5 V,	I _I = -18 mA			-1.2	V
V _{OH}	V _{CC} = 4.5 V,	I _{OH} = -2 mA	2.4	3.5		V
V _{OL}	V _{CC} = 4.5 V,	I _{OL} = 12 mA		0.25	0.5	V
I _{OZH}	V _{CC} = 5.5 V,	V _O = 2.7 V			0.1	mA
I _{OZL}	V _{CC} = 5.5 V,	V _O = 0.4 V			-100	μA
I _I	V _{CC} = 5.5 V,	V _I = 5.5 V			1	mA
I _{IH}	V _{CC} = 5.5 V,	V _I = 2.7 V			25	μA
I _{IL}	V _{CC} = 5.5 V,	V _I = 0.4 V			-0.25	mA
I _{OS} ‡	V _{CC} = 5.5 V,	V _O = 0.5 V	-30		-90	mA
I _{CC}	V _{CC} = 5.5 V,	V _I = GND, Outputs open		120	180	mA

switching characteristics over recommended ranges of supply voltage and operating free-air temperature (unless otherwise noted)

PARAMETER	FROM (INPUT)	TO (OUTPUT)	TEST CONDITIONS	MIN	TYP†	MAX	UNIT
f _{max} ¶	With feedback		R1 = 390 Ω, R2 = 750 Ω, See Figure 4	22			MHz
t _{pd}	I, I/O	I/O			15	30	ns
t _{pd}	I, I/O (reset)	Q			15	35	ns
t _{pd}	CLK	Q			10	20	ns
t _{en}	I, I/O	I/O, Q			15	30	ns
t _{dis}	I, I/O	I/O, Q			15	30	ns

† All typical values are at V_{CC} = 5 V, T_A = 25°C.

‡ Not more than one output should be shorted at a time, and the duration of the short circuit should not exceed one second. V_O is set at 0.5 V to avoid test problems caused by test equipment ground degradation.

$$¶ f_{max} \text{ (with feedback)} = \frac{1}{t_{su} + t_{pd}(\text{CLK to Q})}, \quad f_{max} \text{ (without feedback)} = \frac{1}{t_{w}(\text{low}) + t_{w}(\text{high})}$$



TIBPAL22V10C, TIBPAL22V10AC, TIBPAL22V10AM HIGH-PERFORMANCE *IMPACT*™ PROGRAMMABLE ARRAY LOGIC CIRCUITS

SRPS024A – OCTOBER 1986 – REVISED APRIL 2010

preload procedure for registered outputs (see Notes 2 and 3)

The output registers can be preloaded to any desired state during device testing. This permits any state to be tested without having to step through the entire state-machine sequence. Each register is preloaded individually by following the steps given below:

- Step 1. With V_{CC} at 5 V and pin 1 at V_{IL} , raise pin 13 to V_{IHH} .
- Step 2. Apply either V_{IL} or V_{IH} to the output corresponding to the register to be preloaded.
- Step 3. Pulse pin 1, clocking in preload data.
- Step 4. Remove output voltage, then lower pin 13 to V_{IL} . Preload can be verified by observing the voltage level at the output pin.

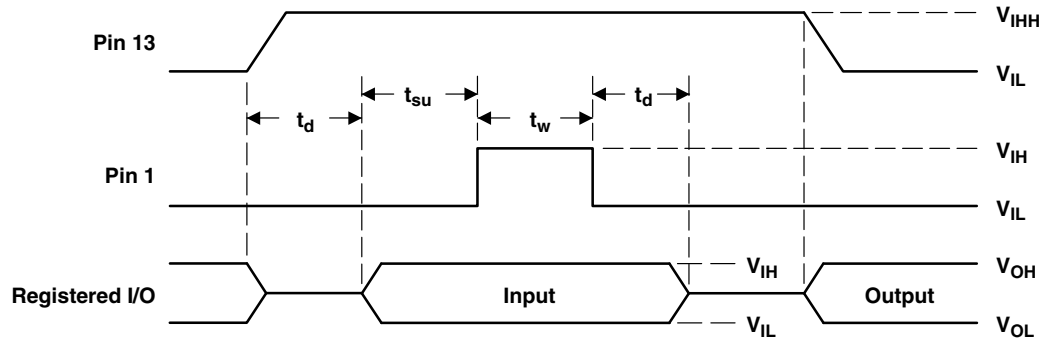

Figure 2. Preload Waveforms

NOTES: 2. Pin numbers shown are for JT and NT packages only. If chip-carrier socket adapter is not used, pin numbers must be changed accordingly.

3. $t_d = t_{su} = t_w = 100$ ns to 1000 ns. $V_{IHH} = 10.25$ V to 10.75 V.

power-up reset

Following power up, all registers are reset to zero. The output level depends on the polarity selected during programming. This feature provides extra flexibility to the system designer and is especially valuable in simplifying state-machine initialization. To ensure a valid power-up reset, it is important that the rise of V_{CC} be monotonic. Following power-up reset, a low-to-high clock transition must not occur until all applicable input and feedback setup times are met.

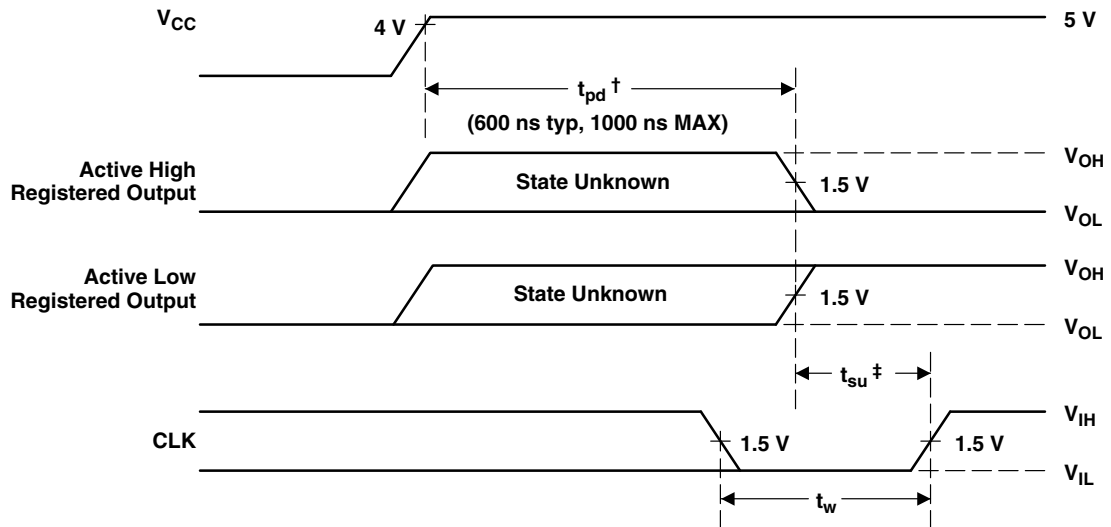

† This is the power-up reset time and applies to registered outputs only. The values shown are from characterization data.

‡ This is the setup time for input or feedback.

Figure 3. Power-Up Reset Waveforms

programming information

Texas Instruments programmable logic devices can be programmed using widely available software and inexpensive device programmers.

Complete programming specifications, algorithms, and the latest information on hardware, software, and firmware are available upon request. Information on programmers capable of programming Texas Instruments programmable logic is also available, upon request, from the nearest TI field sales office, local authorized TI distributor, or by calling Texas Instruments at (214) 997-5666.

PARAMETER MEASUREMENT INFORMATION

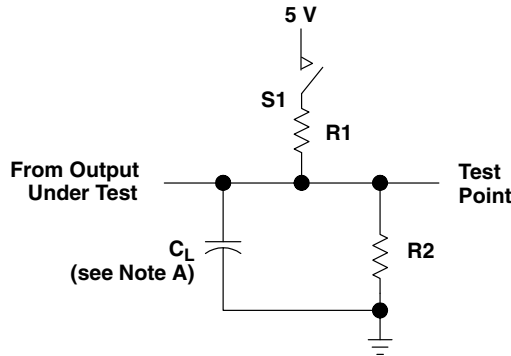

LOAD CIRCUIT FOR 3-STATE OUTPUTS

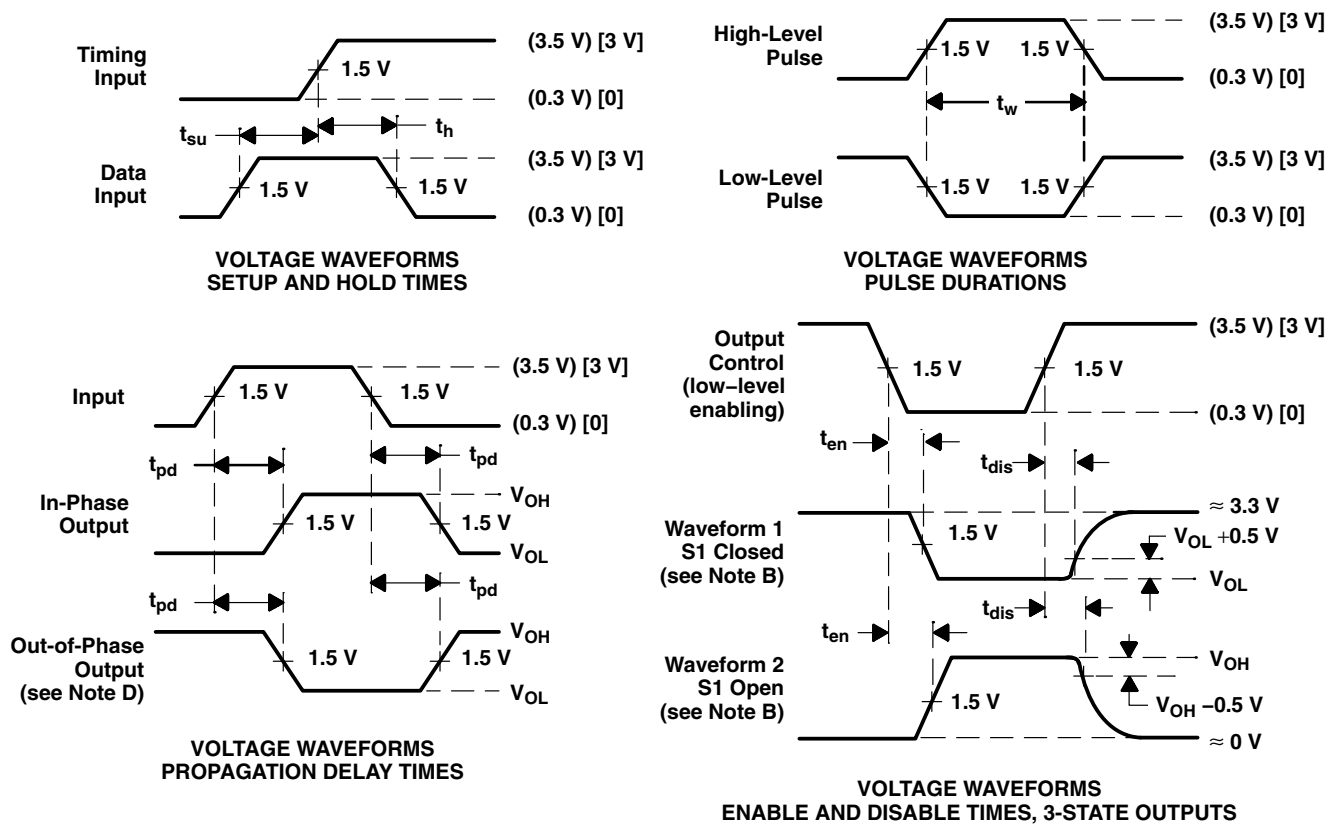

- NOTES: A. C_L includes probe and jig capacitance and is 50 pF for t_{pd} and t_{en} , 5 pF for t_{dis} .
 B. Waveform 1 is for an output with internal conditions such that the output is low except when disabled by the output control. Waveform 2 is for an output with internal conditions such that the output is high except when disabled by the output control.
 C. All input pulses have the following characteristics: For C suffix, use the voltage levels indicated in parentheses (). $PRR \leq 1$ MHz, $t_r = t_f \leq 2$ ns, duty cycle = 50%. For M suffix, use the voltage levels indicated in brackets []. $PRR \leq 10$ MHz, t_r and $t_f \leq 2$ ns, duty cycle = 50%.
 D. When measuring propagation delay times of 3-state outputs, switch S1 is closed.
 E. Equivalent loads may be used for testing.

Figure 4. Load Circuit and Voltage Waveforms

PACKAGING INFORMATION

Orderable Device	Status ⁽¹⁾	Package Type	Package Drawing	Pins	Package Qty	Eco Plan ⁽²⁾	Lead/Ball Finish	MSL Peak Temp ⁽³⁾
5962-86053013A	ACTIVE	LCCC	FK	28	1	TBD	POST-PLATE	N / A for Pkg Type
5962-8605301KA	ACTIVE	CFP	W	24	1	TBD	A42	N / A for Pkg Type
5962-8605301LA	ACTIVE	CDIP	JT	24	1	TBD	A42	N / A for Pkg Type
TIBPAL22V10ACFN	ACTIVE	PLCC	FN	28	37	TBD	CU	Level-1-220C-UNLIM
TIBPAL22V10ACNT	ACTIVE	PDIP	NT	24	15	Pb-Free (RoHS)	CU NIPDAU	N / A for Pkg Type
TIBPAL22V10AMFKB	ACTIVE	LCCC	FK	28	1	TBD	POST-PLATE	N / A for Pkg Type
TIBPAL22V10AMJT	ACTIVE	CDIP	JT	24	1	TBD	A42	N / A for Pkg Type
TIBPAL22V10AMJTB	ACTIVE	CDIP	JT	24	1	TBD	A42	N / A for Pkg Type
TIBPAL22V10AMWB	ACTIVE	CFP	W	24	1	TBD	A42	N / A for Pkg Type

⁽¹⁾ The marketing status values are defined as follows:

ACTIVE: Product device recommended for new designs.

LIFEBUY: TI has announced that the device will be discontinued, and a lifetime-buy period is in effect.

NRND: Not recommended for new designs. Device is in production to support existing customers, but TI does not recommend using this part in a new design.

PREVIEW: Device has been announced but is not in production. Samples may or may not be available.

OBSOLETE: TI has discontinued the production of the device.

⁽²⁾ Eco Plan - The planned eco-friendly classification: Pb-Free (RoHS), Pb-Free (RoHS Exempt), or Green (RoHS & no Sb/Br) - please check <http://www.ti.com/productcontent> for the latest availability information and additional product content details.

TBD: The Pb-Free/Green conversion plan has not been defined.

Pb-Free (RoHS): TI's terms "Lead-Free" or "Pb-Free" mean semiconductor products that are compatible with the current RoHS requirements for all 6 substances, including the requirement that lead not exceed 0.1% by weight in homogeneous materials. Where designed to be soldered at high temperatures, TI Pb-Free products are suitable for use in specified lead-free processes.

Pb-Free (RoHS Exempt): This component has a RoHS exemption for either 1) lead-based flip-chip solder bumps used between the die and package, or 2) lead-based die adhesive used between the die and leadframe. The component is otherwise considered Pb-Free (RoHS compatible) as defined above.

Green (RoHS & no Sb/Br): TI defines "Green" to mean Pb-Free (RoHS compatible), and free of Bromine (Br) and Antimony (Sb) based flame retardants (Br or Sb do not exceed 0.1% by weight in homogeneous material)

⁽³⁾ MSL, Peak Temp. -- The Moisture Sensitivity Level rating according to the JEDEC industry standard classifications, and peak solder temperature.

Important Information and Disclaimer:The information provided on this page represents TI's knowledge and belief as of the date that it is provided. TI bases its knowledge and belief on information provided by third parties, and makes no representation or warranty as to the accuracy of such information. Efforts are underway to better integrate information from third parties. TI has taken and continues to take reasonable steps to provide representative and accurate information but may not have conducted destructive testing or chemical analysis on incoming materials and chemicals. TI and TI suppliers consider certain information to be proprietary, and thus CAS numbers and other limited information may not be available for release.

In no event shall TI's liability arising out of such information exceed the total purchase price of the TI part(s) at issue in this document sold by TI to Customer on an annual basis.

JT (R-GDIP-T**)

CERAMIC DUAL-IN-LINE

24 LEADS SHOWN

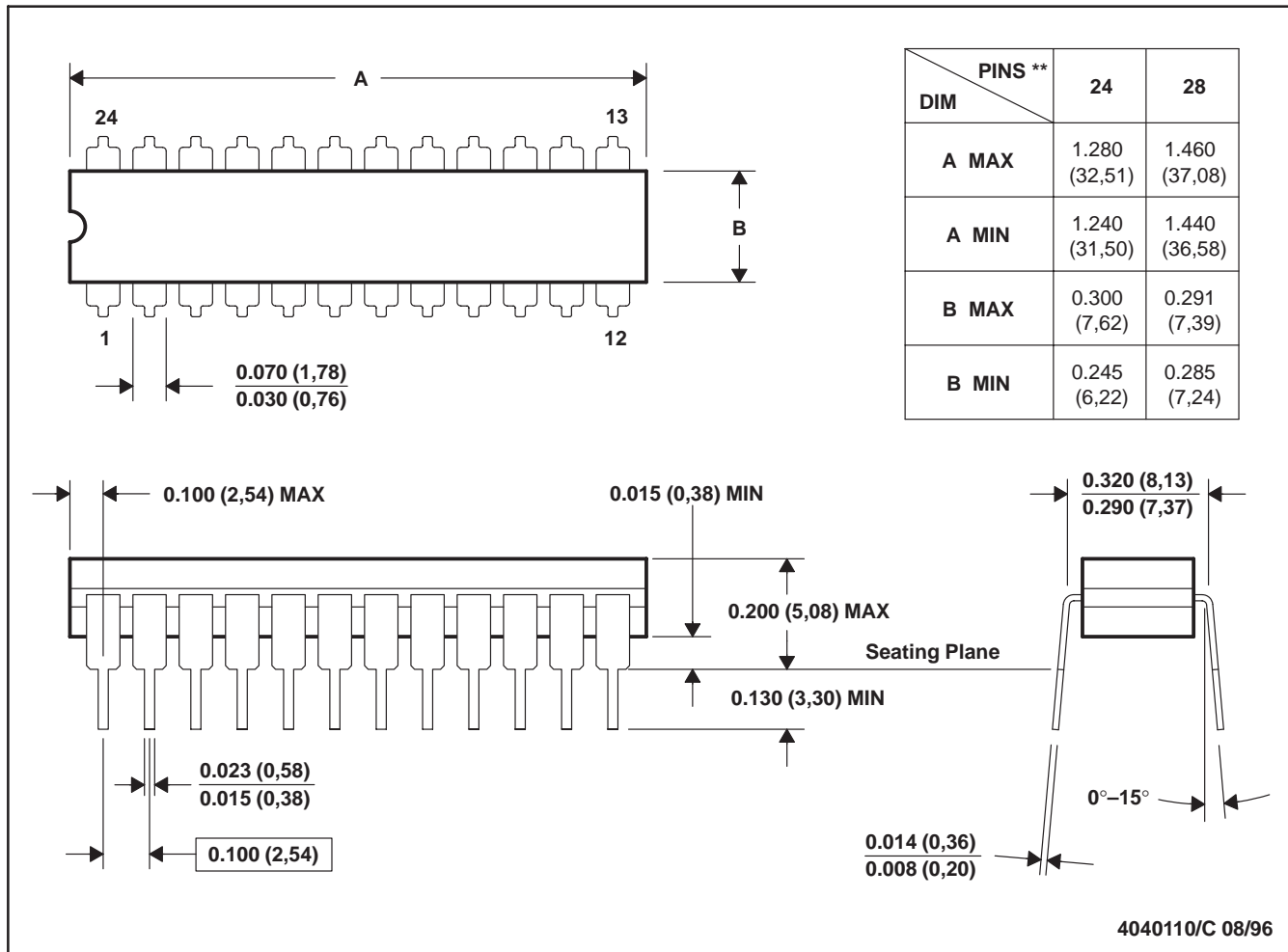

- NOTES: A. All linear dimensions are in inches (millimeters).
 B. This drawing is subject to change without notice.
 C. This package can be hermetically sealed with a ceramic lid using glass frit.
 D. Index point is provided on cap for terminal identification.
 E. Falls within MIL STD 1835 GDIP3-T24, GDIP4-T28, and JEDEC MO-058 AA, MO-058 AB

W (R-GDFP-F24)

CERAMIC DUAL FLATPACK

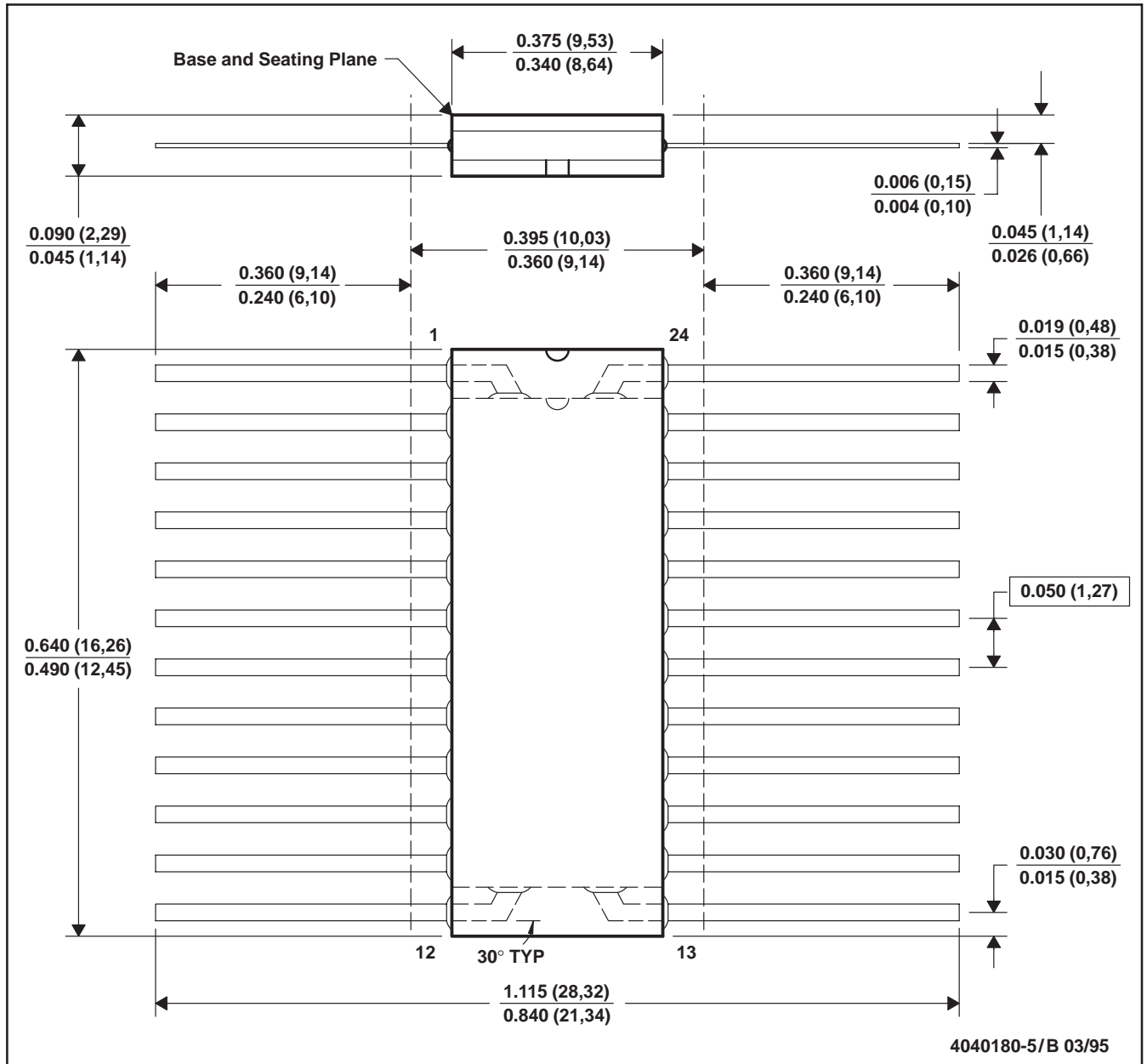

- NOTES:
- A. All linear dimensions are in inches (millimeters).
 - B. This drawing is subject to change without notice.
 - C. This package can be hermetically sealed with a ceramic lid using glass frit.
 - D. Falls within MIL-STD-1835 GDFP2-F24 and JEDEC MO-070AD
 - E. Index point is provided on cap for terminal identification only.

FK (S-CQCC-N**)

LEADLESS CERAMIC CHIP CARRIER

28 TERMINAL SHOWN

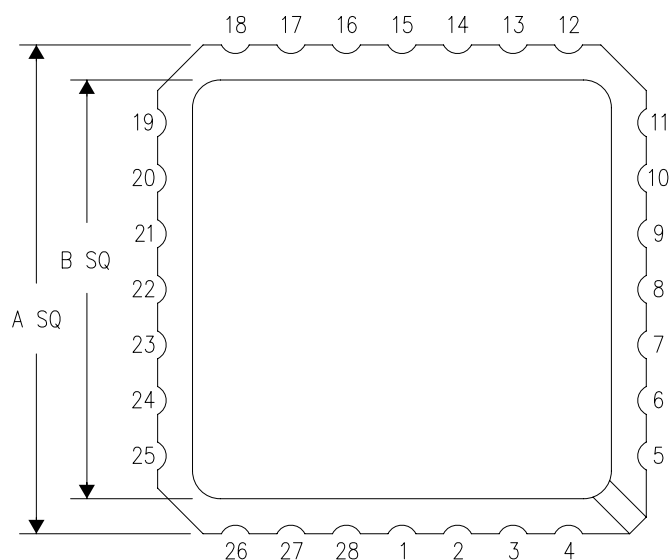

NO. OF TERMINALS **	A		B	
	MIN	MAX	MIN	MAX
20	0.342 (8,69)	0.358 (9,09)	0.307 (7,80)	0.358 (9,09)
28	0.442 (11,23)	0.458 (11,63)	0.406 (10,31)	0.458 (11,63)
44	0.640 (16,26)	0.660 (16,76)	0.495 (12,58)	0.560 (14,22)
52	0.740 (18,78)	0.761 (19,32)	0.495 (12,58)	0.560 (14,22)
68	0.938 (23,83)	0.962 (24,43)	0.850 (21,6)	0.858 (21,8)
84	1.141 (28,99)	1.165 (29,59)	1.047 (26,6)	1.063 (27,0)



4040140/D 01/11

- NOTES:
- All linear dimensions are in inches (millimeters).
 - This drawing is subject to change without notice.
 - This package can be hermetically sealed with a metal lid.
 - Falls within JEDEC MS-004

MECHANICAL DATA

NT (R-PDIP-T**)

PLASTIC DUAL-IN-LINE PACKAGE

24 PINS SHOWN

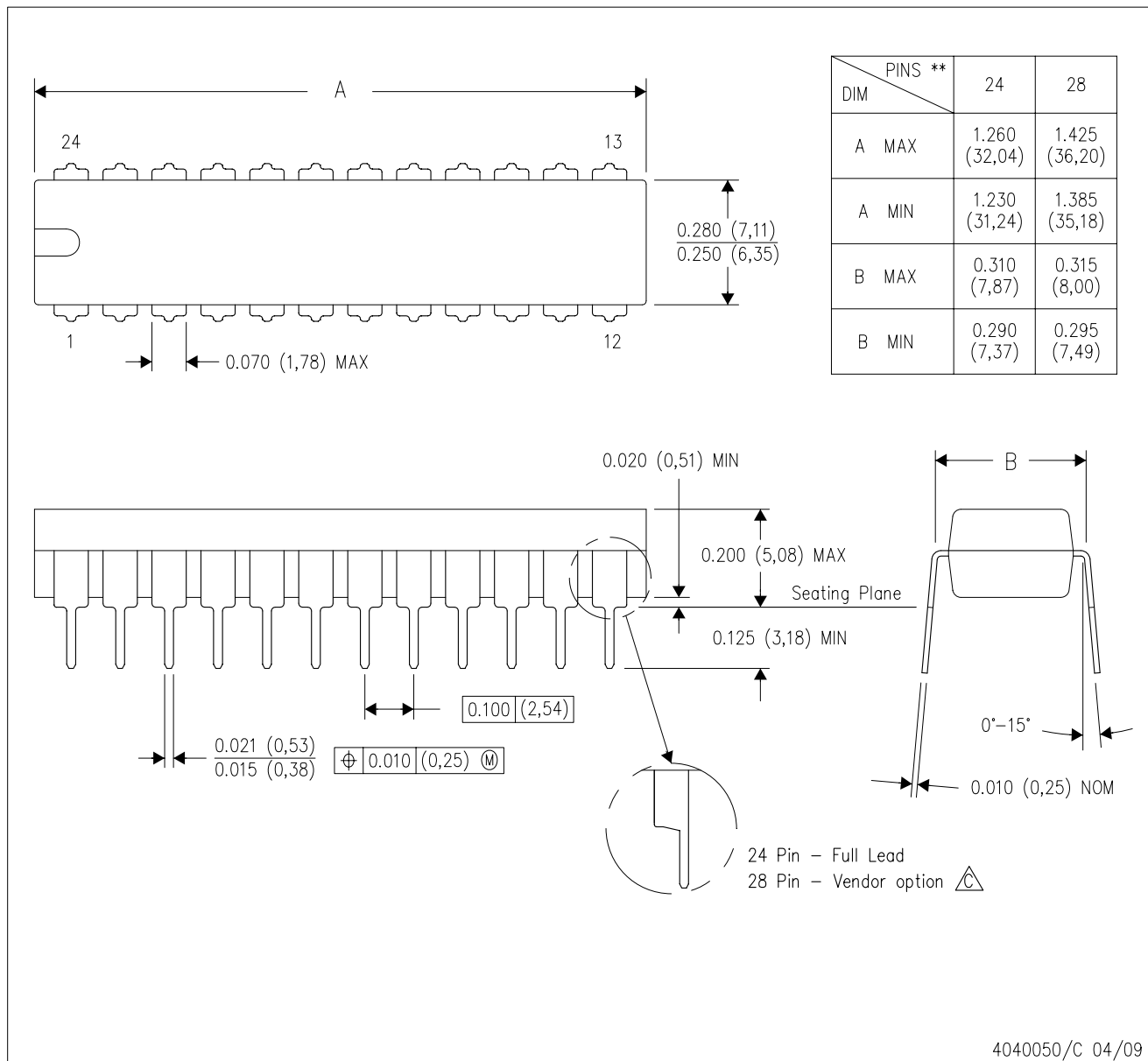

- NOTES:
- A. All linear dimensions are in millimeters. Dimensioning and tolerancing per ASME Y14.5M-1994.
 - B. This drawing is subject to change without notice.
 -  The 28 pin end lead shoulder width is a vendor option, either half or full width.

FN (S-PQCC-J**)

PLASTIC J-LEADED CHIP CARRIER

20 PIN SHOWN

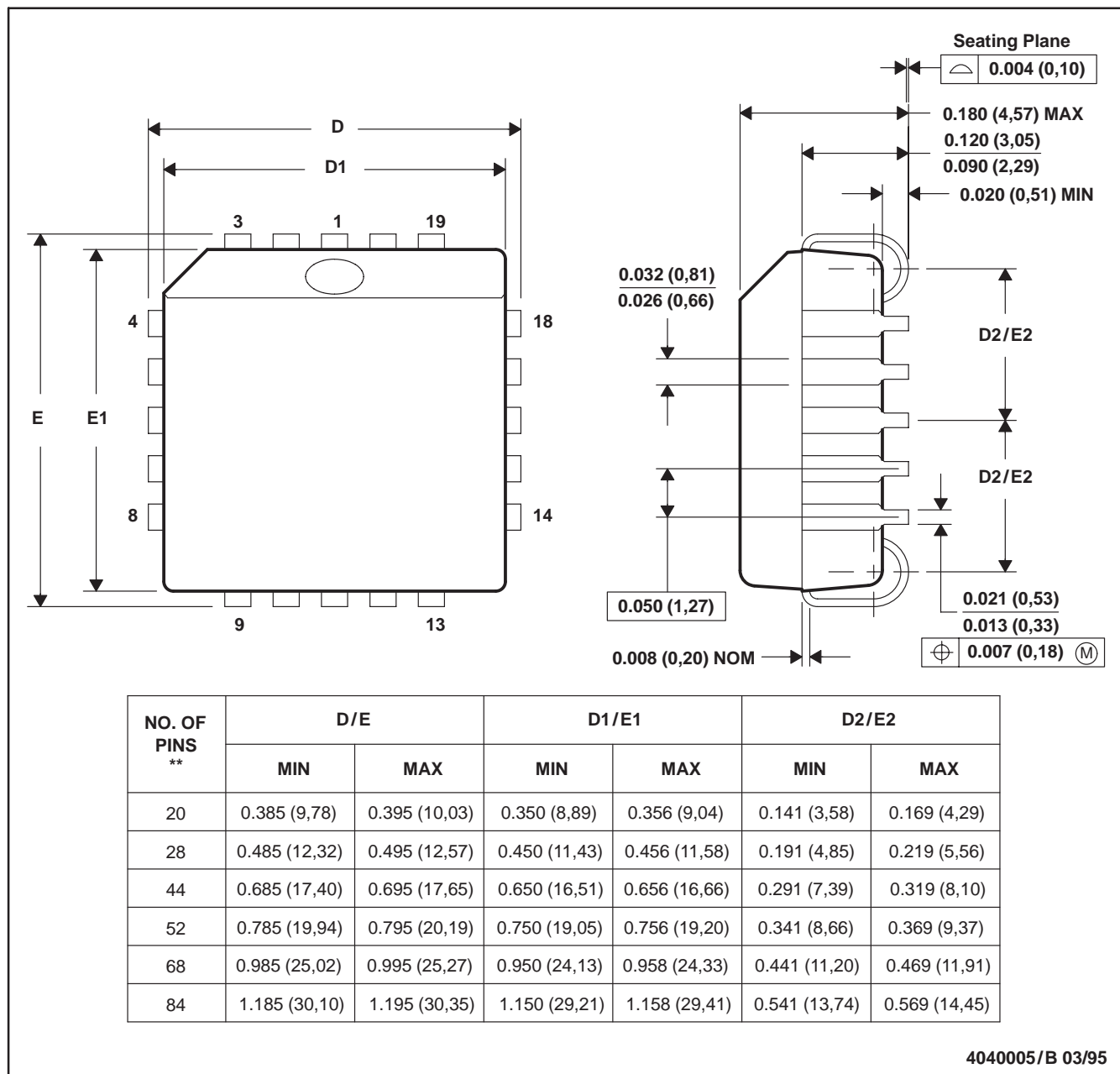

- NOTES: A. All linear dimensions are in inches (millimeters).
 B. This drawing is subject to change without notice.
 C. Falls within JEDEC MS-018

IMPORTANT NOTICE

Texas Instruments Incorporated and its subsidiaries (TI) reserve the right to make corrections, modifications, enhancements, improvements, and other changes to its products and services at any time and to discontinue any product or service without notice. Customers should obtain the latest relevant information before placing orders and should verify that such information is current and complete. All products are sold subject to TI's terms and conditions of sale supplied at the time of order acknowledgment.

TI warrants performance of its hardware products to the specifications applicable at the time of sale in accordance with TI's standard warranty. Testing and other quality control techniques are used to the extent TI deems necessary to support this warranty. Except where mandated by government requirements, testing of all parameters of each product is not necessarily performed.

TI assumes no liability for applications assistance or customer product design. Customers are responsible for their products and applications using TI components. To minimize the risks associated with customer products and applications, customers should provide adequate design and operating safeguards.

TI does not warrant or represent that any license, either express or implied, is granted under any TI patent right, copyright, mask work right, or other TI intellectual property right relating to any combination, machine, or process in which TI products or services are used. Information published by TI regarding third-party products or services does not constitute a license from TI to use such products or services or a warranty or endorsement thereof. Use of such information may require a license from a third party under the patents or other intellectual property of the third party, or a license from TI under the patents or other intellectual property of TI.

Reproduction of TI information in TI data books or data sheets is permissible only if reproduction is without alteration and is accompanied by all associated warranties, conditions, limitations, and notices. Reproduction of this information with alteration is an unfair and deceptive business practice. TI is not responsible or liable for such altered documentation. Information of third parties may be subject to additional restrictions.

Resale of TI products or services with statements different from or beyond the parameters stated by TI for that product or service voids all express and any implied warranties for the associated TI product or service and is an unfair and deceptive business practice. TI is not responsible or liable for any such statements.

TI products are not authorized for use in safety-critical applications (such as life support) where a failure of the TI product would reasonably be expected to cause severe personal injury or death, unless officers of the parties have executed an agreement specifically governing such use. Buyers represent that they have all necessary expertise in the safety and regulatory ramifications of their applications, and acknowledge and agree that they are solely responsible for all legal, regulatory and safety-related requirements concerning their products and any use of TI products in such safety-critical applications, notwithstanding any applications-related information or support that may be provided by TI. Further, Buyers must fully indemnify TI and its representatives against any damages arising out of the use of TI products in such safety-critical applications.

TI products are neither designed nor intended for use in military/aerospace applications or environments unless the TI products are specifically designated by TI as military-grade or "enhanced plastic." Only products designated by TI as military-grade meet military specifications. Buyers acknowledge and agree that any such use of TI products which TI has not designated as military-grade is solely at the Buyer's risk, and that they are solely responsible for compliance with all legal and regulatory requirements in connection with such use.

TI products are neither designed nor intended for use in automotive applications or environments unless the specific TI products are designated by TI as compliant with ISO/TS 16949 requirements. Buyers acknowledge and agree that, if they use any non-designated products in automotive applications, TI will not be responsible for any failure to meet such requirements.

Following are URLs where you can obtain information on other Texas Instruments products and application solutions:

Products

Audio	www.ti.com/audio
Amplifiers	amplifier.ti.com
Data Converters	dataconverter.ti.com
DLP® Products	www.dlp.com
DSP	dsp.ti.com
Clocks and Timers	www.ti.com/clocks
Interface	interface.ti.com
Logic	logic.ti.com
Power Mgmt	power.ti.com
Microcontrollers	microcontroller.ti.com
RFID	www.ti-rfid.com
RF/IF and ZigBee® Solutions	www.ti.com/lprf

Applications

Communications and Telecom	www.ti.com/communications
Computers and Peripherals	www.ti.com/computers
Consumer Electronics	www.ti.com/consumer-apps
Energy and Lighting	www.ti.com/energy
Industrial	www.ti.com/industrial
Medical	www.ti.com/medical
Security	www.ti.com/security
Space, Avionics and Defense	www.ti.com/space-avionics-defense
Transportation and Automotive	www.ti.com/automotive
Video and Imaging	www.ti.com/video
Wireless	www.ti.com/wireless-apps

TI E2E Community Home Page

e2e.ti.com

Mailing Address: Texas Instruments, Post Office Box 655303, Dallas, Texas 75265
Copyright © 2011, Texas Instruments Incorporated