

## PESD5V0S1BBN

### 1. Description

The PESD5V0S1BBN is designed to protect voltage sensitive components from damage or latch-up due to ESD. Excellent clamping capability, low leakage, and fast response time provide best in class protection on designs that are exposed to ESD for board level. Because of its small size and bi-directional design, it is ideal for use in cellular phones, MP3 players, and portable applications that require audio line protection.

### 2. Features

- IEC 61000-4-2 Level 4 ESD Protection
  - ±25kV Contact Discharge
  - ±25kV Air Discharge
- 80W Peak pulse Power (8/20us)
- Low clamping voltage
- Working voltage: 5V
- Low leakage current
- RoHS compliant
- Protecting one bi-directional lines
- Junction capacitance: 15pF Typ.

### 3. Applications

- Cellular handsets and accessories
- Portable digital assistants
- Notebooks & handhelds
- Digital cameras
- MP3 players
- Peripherals

### 4. Ordering Information

Part Number	Package	Marking	Material	Packing	Quantity per reel	Flammability Rating	Reel Size
PESD5V0S1BBN	SOD-523	DT/5XB	Halogen free	Tape & Reel	3,000 PCS	UL 94V-0	7 inches

Table-1 Ordering information



## 5. Pin Configuration and Functions

Pin	Name	Description	Outline	Circuit Diagram
1	IO1	Connect to IO		
2	IO2	Connect to IO		

Table-2 Pin configuration

## 6. Specification

### 6.1. Absolute Maximum rating

Over operating free-air temperature range (unless otherwise noted)

Parameters	Symbol	Min.	Max.	Unit
Peak pulse power (tp=8/20us)@25°C	P <sub>pk</sub>	-	80	W
Peak pulse current (tp=8/20us)@25°C	I <sub>PP</sub>		8	A
ESD (IEC61000-4-2 air discharge) @25°C	V <sub>ESD</sub>	-	±25	kV
ESD (IEC61000-4-2 contact discharge) @25°C	V <sub>ESD</sub>	-	±25	kV
Junction temperature	T <sub>J</sub>	-	125	°C
Operating temperature	T <sub>OP</sub>	-40	85	°C
Storage temperature	T <sub>STG</sub>	-55	150	°C
Lead temperature	T <sub>L</sub>	-	260	°C

Table-3 Absolute Maximum rating

## 6.2. Electrical Characteristics

At TA = 25°C unless otherwise noted

Parameter	Symbol	Conditions	Min.	Typ.	Max.	Units
Reverse Stand-off Voltage	$V_{RWM}$				5	V
Reverse Breakdown Voltage	$V_{BR}$	$I_T=1mA$	5.8			V
Reverse Leakage Current	$I_R$	$V_{RWM}=5V$			1	$\mu A$
Clamping Voltage	$V_C$	$I_{PP}=1A$ ; $t_p=8/20\mu s$		6		V
Clamping Voltage	$V_C$	$I_{PP}=8A$ ; $t_p=8/20\mu s$		10		V
Junction Capacitance	$C_J$	I/O to GND; $V_R=0V$ ; $f=1MHz$		15		pF

Table-4 Electrical Characteristics

Symbol	Parameters
$V_{RWM}$	Peak Reverse Working Voltage
$I_R$	Reverse Leakage Current @ $V_{RWM}$
$V_{BR}$	Breakdown Voltage @ $I_T$
$I_T$	Test Current
$I_{PP}$	Maximum Reverse Peak Pulse Current
$V_C$	Clamping Voltage @ $I_{PP}$
$I_F$	Forward Current
$V_F$	Forward Voltage @ $I_F$

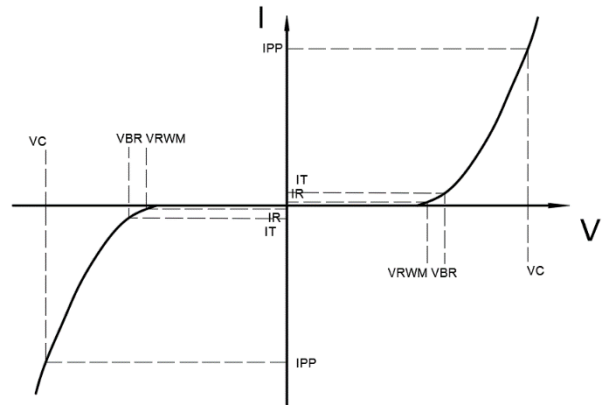



### 7. Typical Characteristic

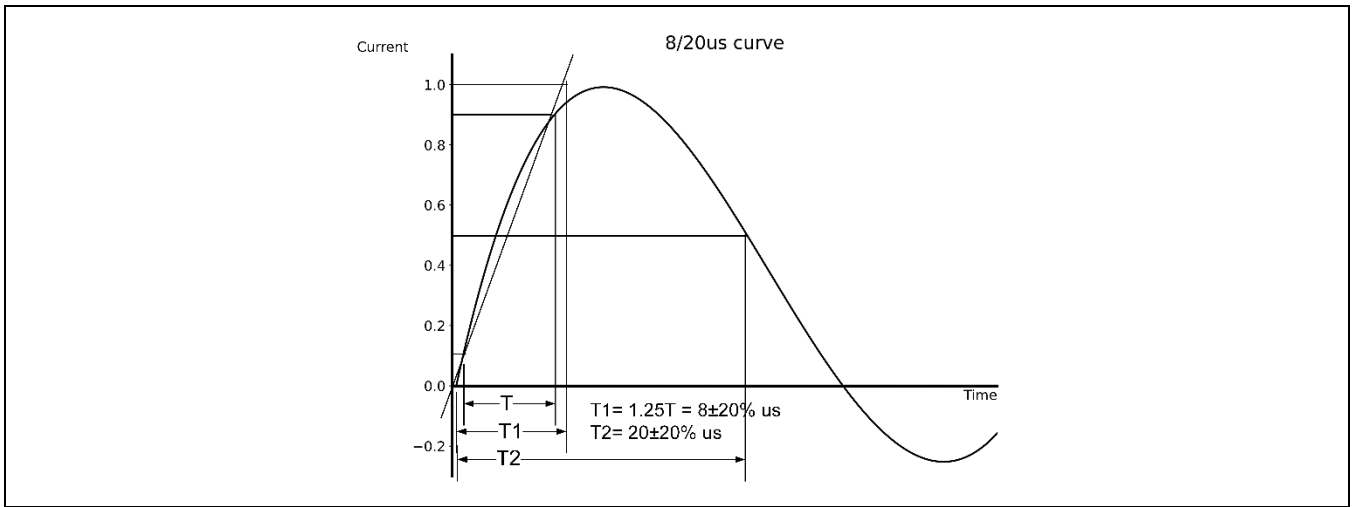

### 8. Typical Application

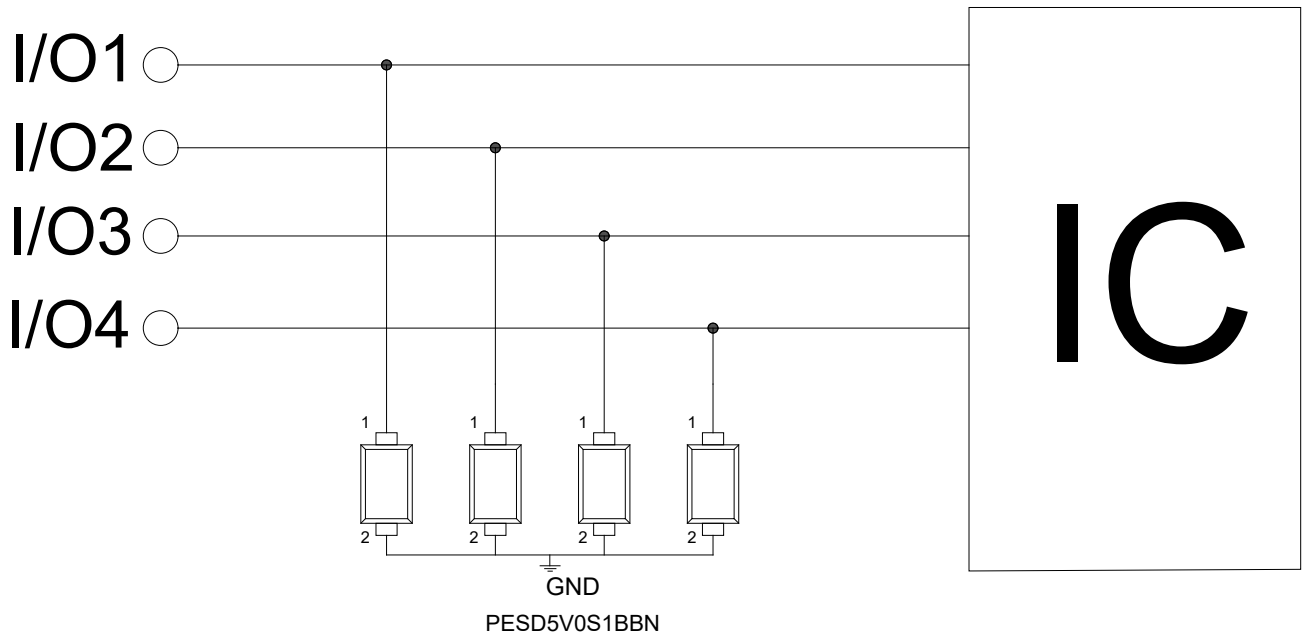

Typical Interface Application



9. Dimension

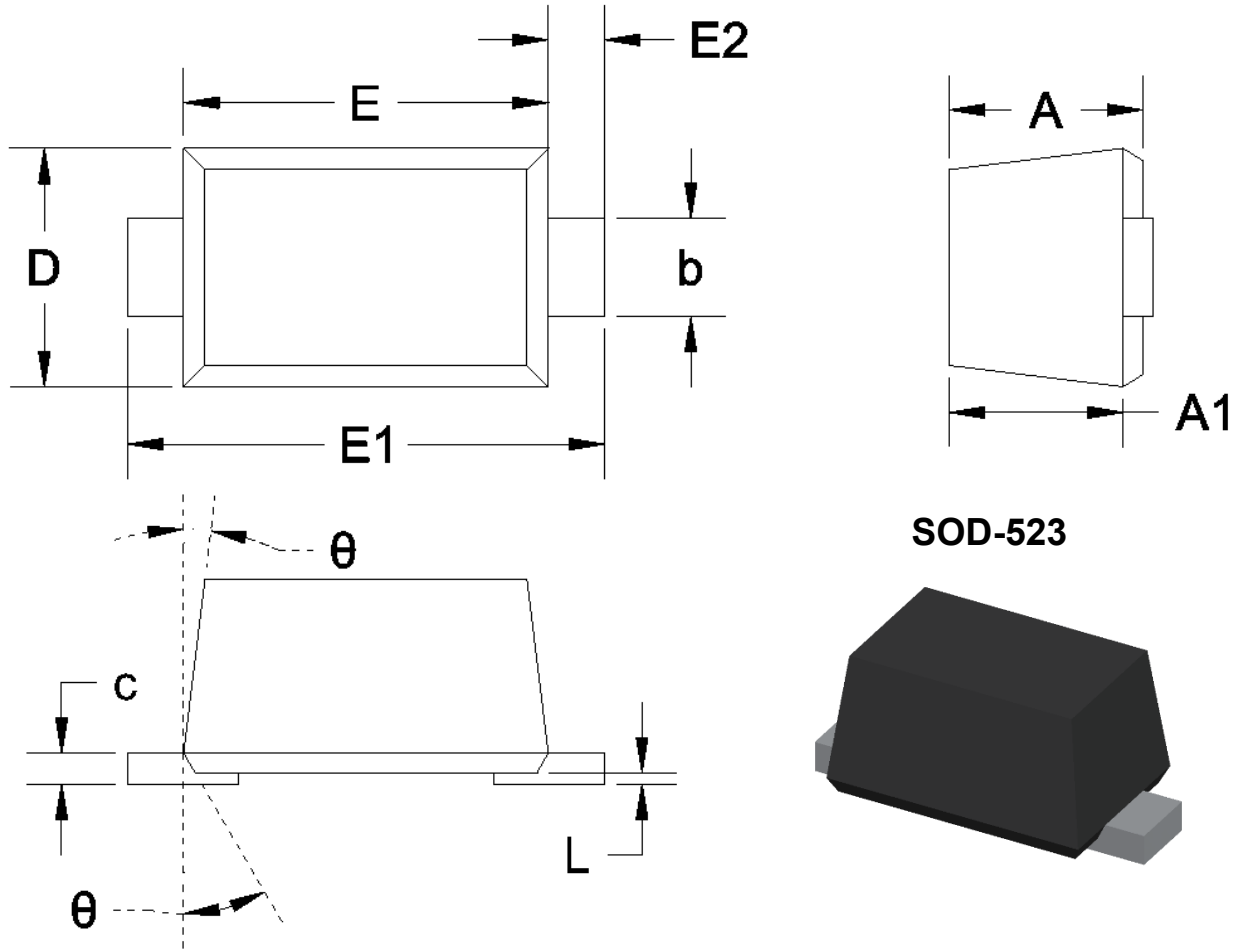

Unit	A	A1	b	c	D	E	E1	E2	L	$\theta$
Max.	0.77	0.70	0.35	0.15	0.85	1.30	1.70	0.20	0.07	7°
Min.	0.51	0.50	0.25	0.08	0.75	1.10	1.50	REF.	0.01	REF.

Table-5 Product dimensions in millimeter



### 10. Recommended Land Pattern

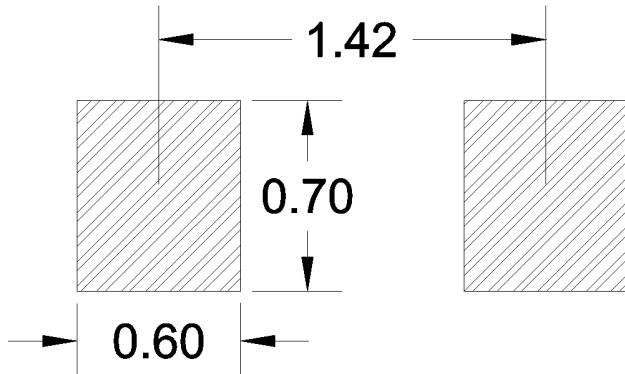

Note:

1. Controlling dimension: in millimeters
2. General tolerance:  $\pm 0.05\text{mm}$
3. The pad layout is for reference only
4. Unit: mm