

Jun.1.2024 Copyright 2024 HIROSE ELECTRIC CO., LTD. All Rights Reserved.  
In case of consideration for using Automotive equipment / device which demand high reliability, kindly contact our sales window correspondents.

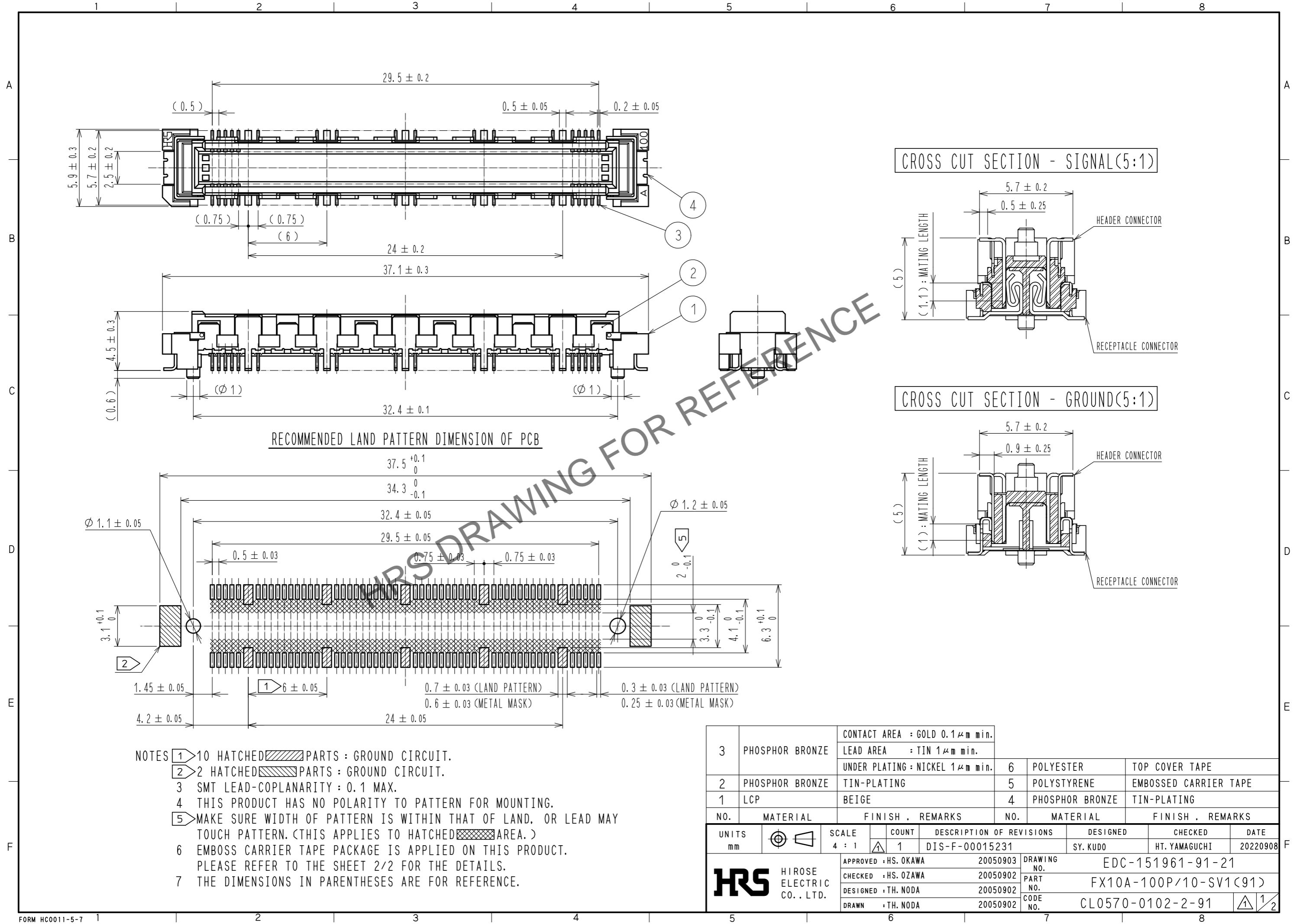

- NOTES
- 1 10 HATCHED PARTS : GROUND CIRCUIT.
  - 2 2 HATCHED PARTS : GROUND CIRCUIT.
  - 3 SMT LEAD-COPLANARITY : 0.1 MAX.
  - 4 THIS PRODUCT HAS NO POLARITY TO PATTERN FOR MOUNTING.
  - 5 MAKE SURE WIDTH OF PATTERN IS WITHIN THAT OF LAND. OR LEAD MAY TOUCH PATTERN. (THIS APPLIES TO HATCHED AREA.)
  - 6 EMBOSS CARRIER TAPE PACKAGE IS APPLIED ON THIS PRODUCT. PLEASE REFER TO THE SHEET 2/2 FOR THE DETAILS.
  - 7 THE DIMENSIONS IN PARENTHESES ARE FOR REFERENCE.

3	PHOSPHOR BRONZE	CONTACT AREA : GOLD 0.1 μm min.	6	POLYESTER	TOP COVER TAPE
		LEAD AREA : TIN 1 μm min.			
		UNDER PLATING : NICKEL 1 μm min.			
2	PHOSPHOR BRONZE	TIN-PLATING	5	POLYSTYRENE	EMBOSSED CARRIER TAPE
1	LCP	BEIGE	4	PHOSPHOR BRONZE	TIN-PLATING
NO.	MATERIAL	FINISH . REMARKS	NO.	MATERIAL	FINISH . REMARKS
UNITS mm		SCALE 4 : 1	COUNT 1	DESCRIPTION OF REVISIONS DIS-F-00015231	
DESIGNED SY. KUDO			CHECKED HT. YAMAGUCHI		
DATE 20220908			DRAWING NO. EDC-151961-91-21		
APPROVED : HS. OKAWA 20050903			PART NO. FX10A-100P/10-SV1(91)		
CHECKED : HS. OZAWA 20050902			CODE NO. CL0570-0102-2-91		
DESIGNED : TH. NODA 20050902			1/2		
DRAWN : TH. NODA 20050902					

Jun.1.2024 Copyright 2024 HIROSE ELECTRIC CO., LTD. All Rights Reserved.  
 In case of consideration for using Automotive equipment / device which demand high reliability, kindly contact our sales window correspondents.

DRAWING FOR PACKING (2:1)

REELED DIMENSION (Free)

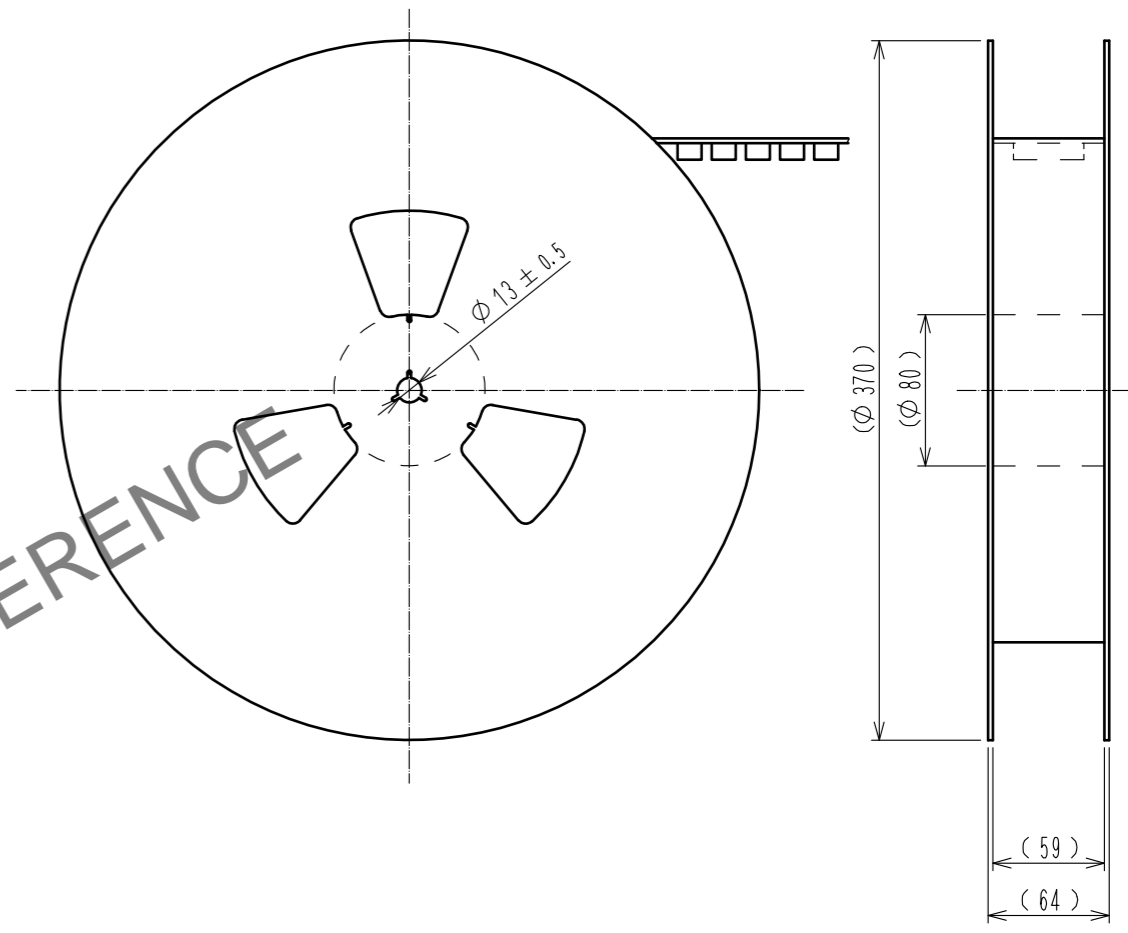
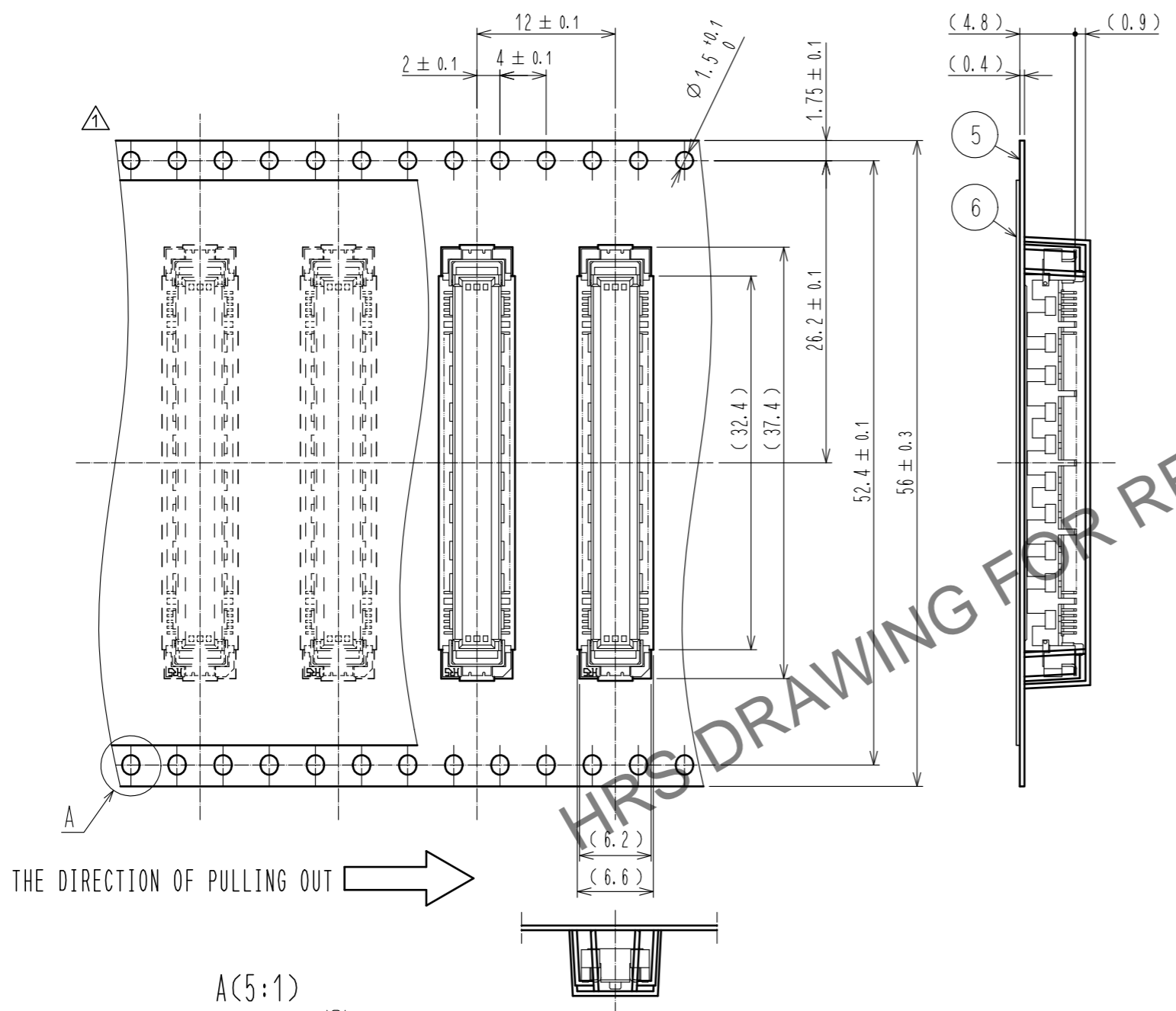

THE DIRECTION OF PULLING OUT

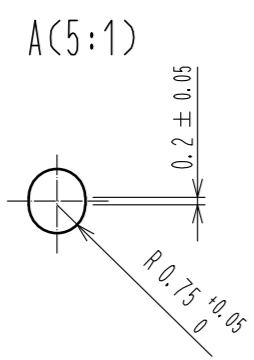

- NOTES 8 1 REEL : 1000 CONNECTORS.  
 9 MINIMUM 10 COMPARTMENTS FROM BOTH REEL ENDS REMAIN EMPTY.  
 10 THIS PRODUCT HAS NO POLARITY TO TAPE AND REEL PACKAGING.  
 11 THE DIMENSIONS IN PARENTHESES ARE FOR REFERENCE.

<b>HRS</b>	DRAWING NO.	EDC-151961-91-21	2/2
	PART NO.	FX10A-100P/10-SV1(91)	
	CODE NO.	CL0570-0102-2-91	