

PULL OUT DIRECTION

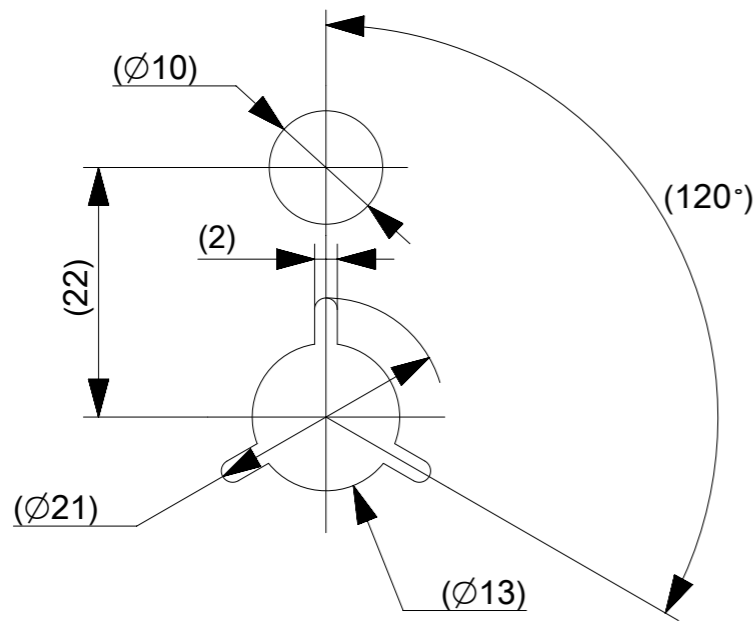
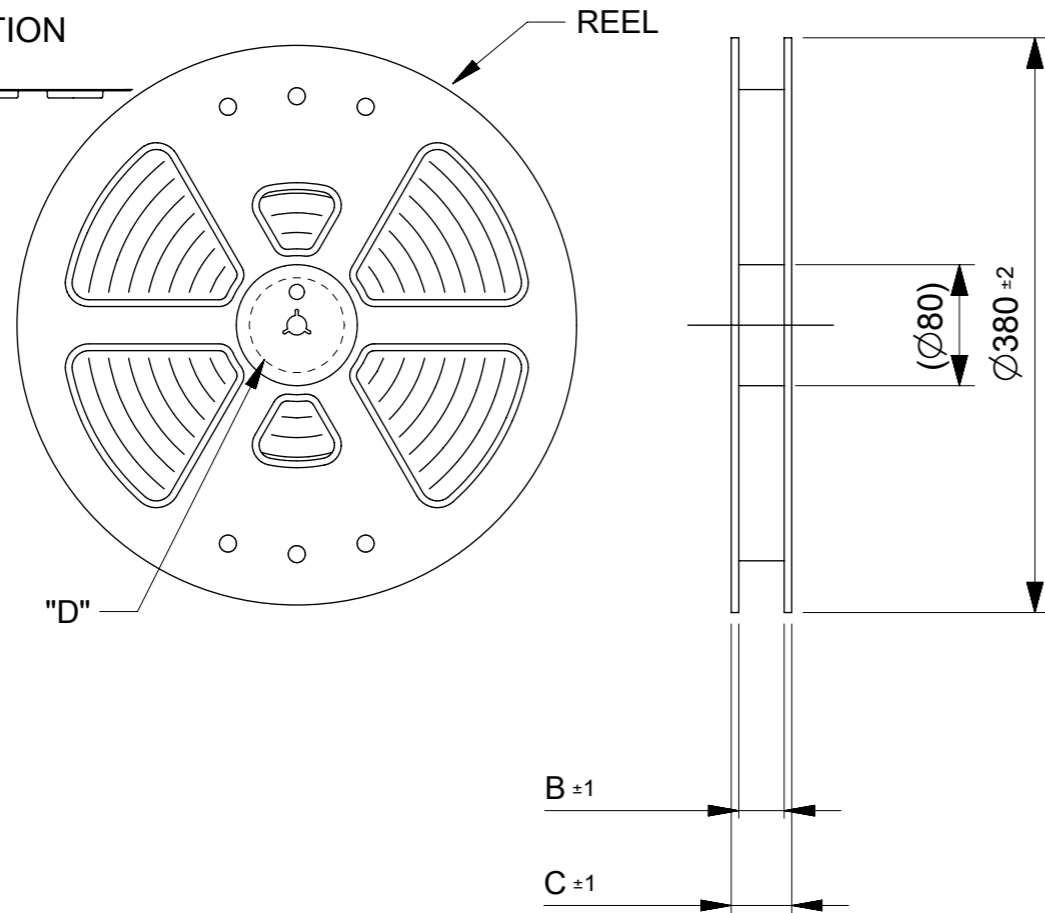

DETAIL "D"

NOTES

1. RE DETAILED DIMENSION, SEE PRODUCT DRAWING.
2. NUMBER OF CONNECTORS : 8000 PCS/REEL.
3. LEAD TAPE LENGTH.

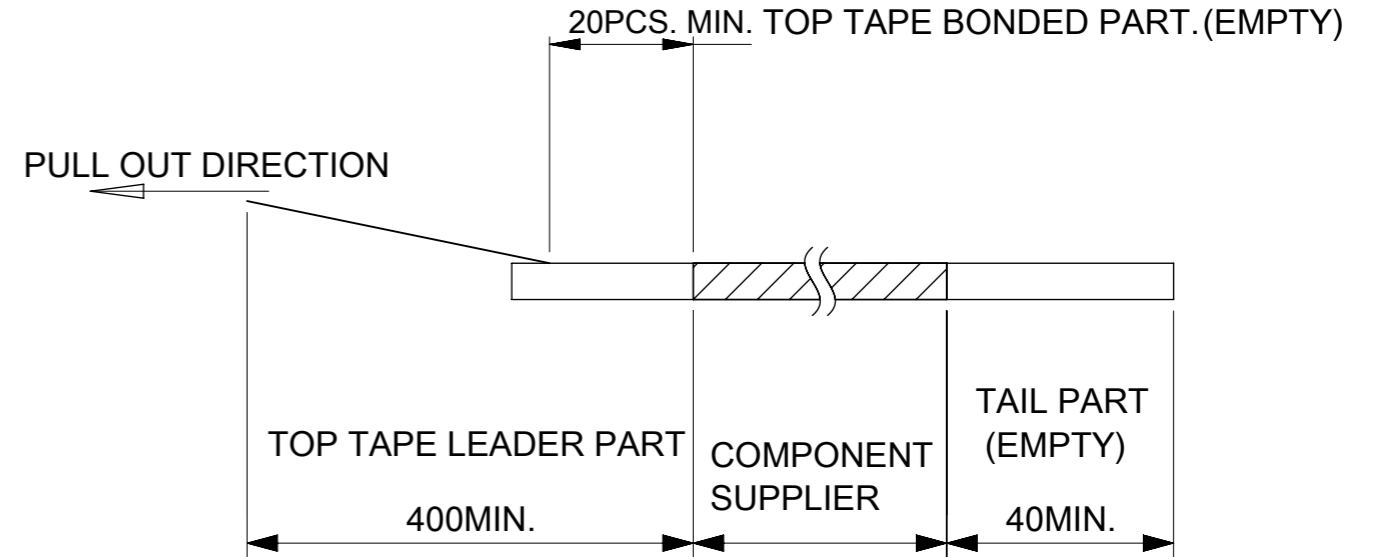

4. TOP TAPE PEEL FORCE IS DEFINED BY IEC60286-3
5. MATERIAL
 CARRER TAPE :POLYSTYRENE
 TOP TAPE :PET , OTHER
 REEL :POLYSTYRENE(PS)(RECYCLE MATERIAL CONTAINED)

MODEL NO. 505066-**22

| | | | | | | |
|---|--|-----------------------------|------------------------|--------------------------|---------|----------------------------|
| THIS DRAWING CONTAINS INFORMATION THAT IS PROPRIETARY TO MOLEX ELECTRONIC TECHNOLOGIES, LLC AND SHOULD NOT BE USED WITHOUT WRITTEN PERMISSION | | CURRENT REV DESC: | | molex | | |
| DIMENSION UNITS | SCALE | EC NO: 730166 | | | | |
| mm | 1:5 | DRWN: RAJAGN 2022/11/28 | | PRODUCT CUSTOMER DRAWING | | |
| GENERAL TOLERANCES (UNLESS SPECIFIED) | | CHK'D: YNUKANOBU 2022/11/30 | | DOCUMENT NUMBER | | |
| ANGULAR TOL ± 1.0° | | APPR: YNAITO 2022/11/30 | | 5050660000 | | DOC TYPE DOC PART REVISION |
| 4 PLACES ± 0.01 | INITIAL REVISION: | | 2017/03/28 | | PSD | 008 |
| 3 PLACES ± 0.03 | DRWN: TNISHIDA02 | | 2017/04/03 | | E | |
| 2 PLACES ± 0.05 | APPR: TKUSUHARA01 | | | | | |
| 1 PLACE ± 0.1 | DRAFT WHERE APPLICABLE MUST REMAIN WITHIN DIMENSIONS | | THIRD ANGLE PROJECTION | DRAWING | SERIES | MATERIAL NUMBER |
| 0 PLACES ± 0.2 | | | | A3-SIZE | 505066 | CUSTOMER |
| | | | | SEE TABLE | GENERAL | SHEET NUMBER |
| | | | | | | 1 OF 3 |

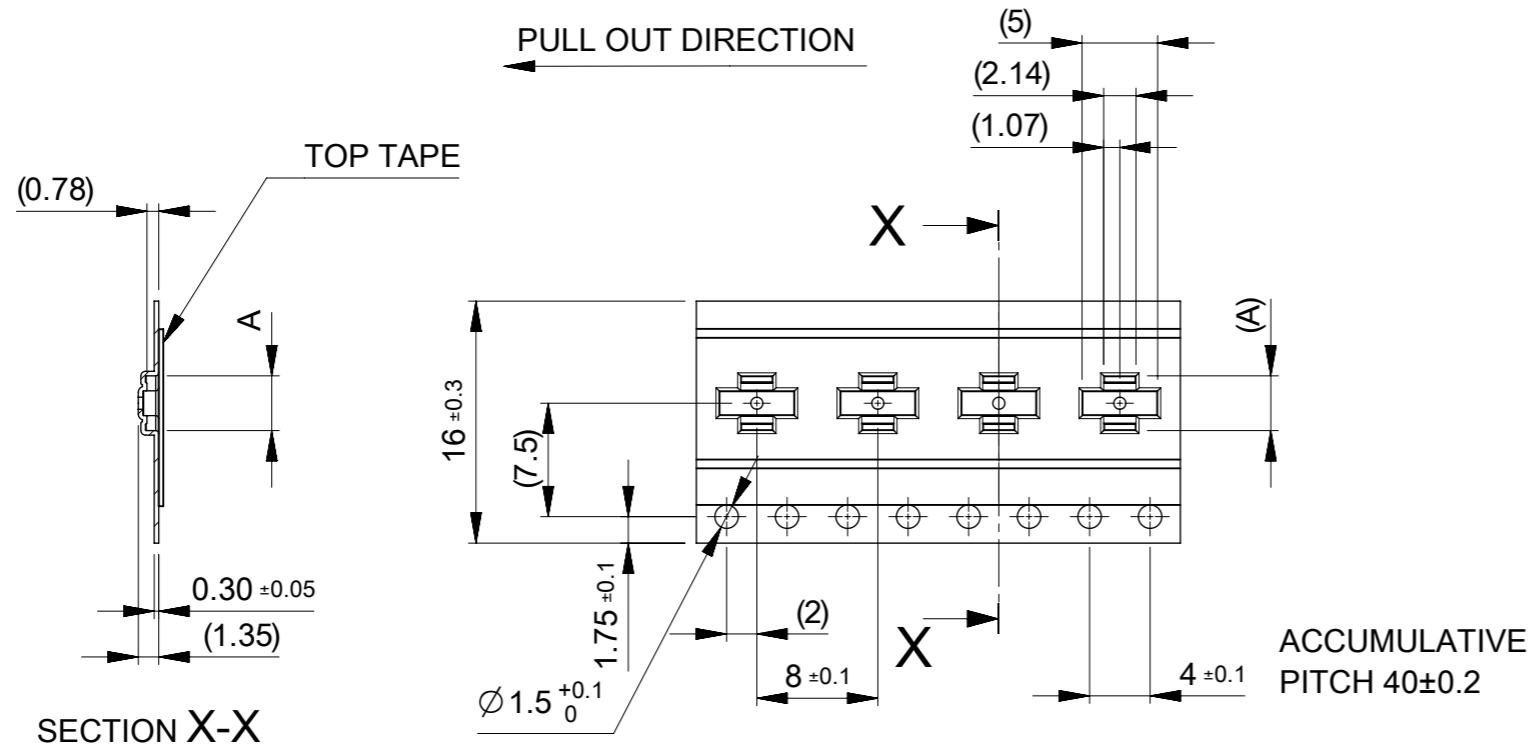

| | | | | | | | |
|--------------------------------|------|------|------|--------------|--------------------|---------------|---------|
| 16 | 21.4 | 17.4 | 7.82 | 505066-3022 | ○ | --- | 30 |
| | | | 6.42 | 505066-2222 | ○ | --- | 22 |
| | | | 6.07 | 505066-2022 | ○ | --- | 20 |
| | | | 5.72 | 505066-1822 | --- | --- | 18 |
| | | | 5.02 | 505066-1422 | ○ | --- | 14 |
| | | | 4.67 | 505066-1222 | ○ | --- | 12 |
| | | | 4.32 | 505066-1022 | ○ | --- | 10 |
| | | | 3.97 | 505066-0822 | ○ | --- | 8 |
| | | | 3.62 | 505066-0622 | ○ | --- | 6 |
| キャリアテープ幅 CARRIER TAPE WIDTH | C | B | (A) | MATERIAL No. | HIGH VOL. TOOL | LOW VOL. TOOL | CIRCUIT |
| | | | | | SAMPLE PREPARATION | | |

THIS DRAWING CONTAINS INFORMATION THAT IS PROPRIETARY TO MOLEX ELECTRONIC TECHNOLOGIES, LLC AND SHOULD NOT BE USED WITHOUT WRITTEN PERMISSION

| | | | | | | | |
|--|--------------|------------------------|---------|-----------------|-----------------|----------|--------------------------------------|
| DIMENSION UNITS mm | SCALE 2:1 | CURRENT REV DESC: | | molex | | | |
| GENERAL TOLERANCES (UNLESS SPECIFIED) | | EC NO: 730166 | | | | | 0.35 BB CONN. H=0.6 SSB6 RP REC ASSY |
| ANGULAR TOL | ± 1.0° | DRWN: RAJAGN | | 2022/11/28 | | | |
| 4 PLACES | ± 0.01 | CHK'D: YNUKANOBU | | 2022/11/30 | | | |
| 3 PLACES | ± 0.03 | APPR: YNAITO | | 2022/11/30 | | | |
| 2 PLACES | ± 0.05 | INITIAL REVISION: | | DOCUMENT NUMBER | | | |
| 1 PLACE | ± 0.1 | DRWN: TNISHIDA02 | | 5050660000 | | DOC TYPE | |
| 0 PLACES | ± 0.2 | APPR: TKUSUHARA01 | | 2017/03/28 | | DOC PART | |
| DRAFT WHERE APPLICABLE MUST REMAIN WITHIN DIMENSIONS | | THIRD ANGLE PROJECTION | DRAWING | SERIES | MATERIAL NUMBER | CUSTOMER | REVISION |
| | | | A3-SIZE | 505066 | SEE TABLE | GENERAL | E |
| | | | | | | | SHEET NUMBER |
| | | | | | | | 2 OF 3 |

PULL OUT DIRECTION

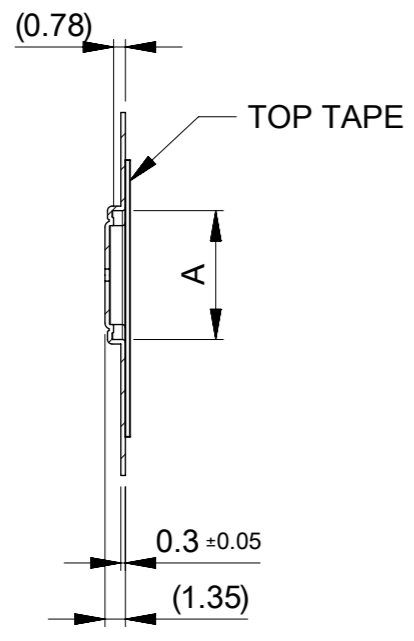

SECTION Y-Y

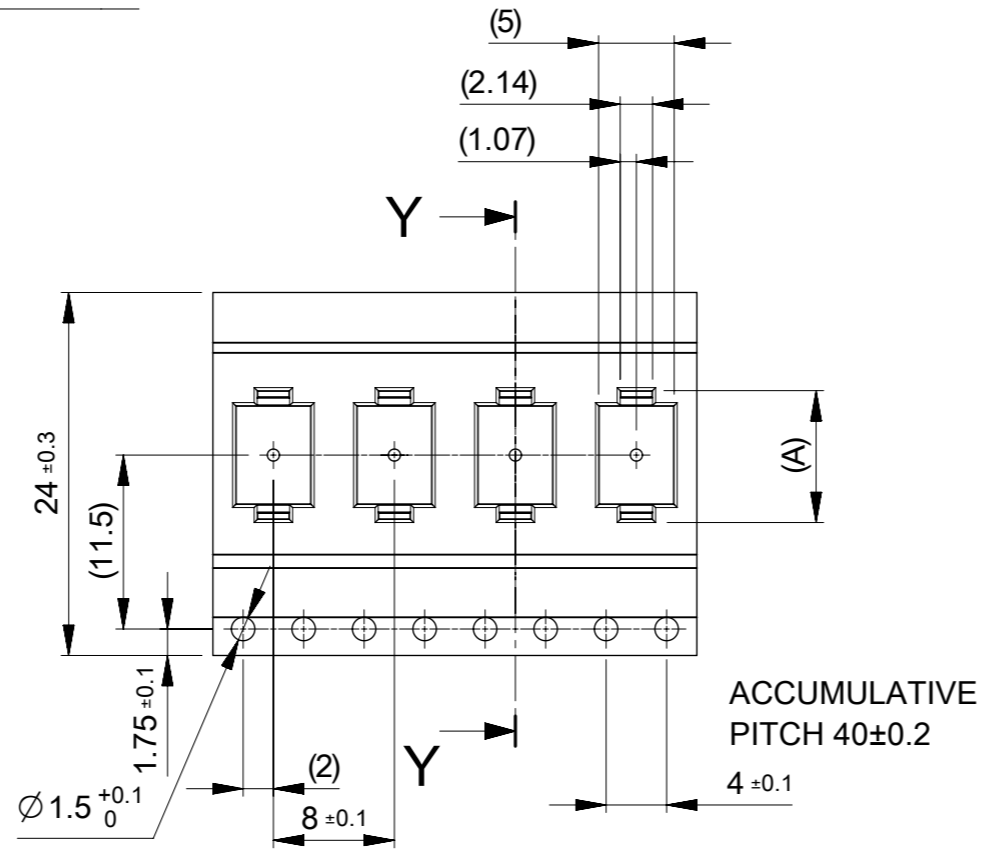

| | | | | | | | |
|--------------------------------|-------------|------|-------|--------------|--------------------|--------------|---------|
| 24 | 29.4 | 25.4 | 13.77 | 505066-6422 | --- | --- | 64 |
| | | | 13.07 | 505066-6022 | --- | --- | 60 |
| | | | 12.02 | 505066-5422 | ○ | --- | 54 |
| | | | 11.32 | 505066-5022 | ○ | --- | 50 |
| | | | 10.99 | 505066-4822 | ○ | --- | 48 |
| | | | 10.62 | 505066-4622 | --- | --- | 46 |
| | | | 9.92 | 505066-4222 | ○ | --- | 42 |
| | | | 9.57 | 505066-4022 | ○ | --- | 40 |
| | | | 8.52 | 505066-3422 | ○ | --- | 34 |
| 8.17 | 505066-3222 | --- | --- | 32 | | | |
| キャリアテープ幅 CARRIER TAPE WIDTH | C | B | (A) | MATERIAL No. | HIGH VOL TOOL | LOW VOL TOOL | CIRCUIT |
| | | | | | SAMPLE PREPARATION | | |

THIS DRAWING CONTAINS INFORMATION THAT IS PROPRIETARY TO MOLEX ELECTRONIC TECHNOLOGIES, LLC AND SHOULD NOT BE USED WITHOUT WRITTEN PERMISSION

| | | | | | | | |
|--|--------------|------------------------|---------|-----------------|-----------------|----------|--------------------------------------|
| DIMENSION UNITS mm | SCALE 2:1 | CURRENT REV DESC: | | molex | | | |
| GENERAL TOLERANCES (UNLESS SPECIFIED) | | EC NO: 730166 | | | | | 0.35 BB CONN. H=0.6 SSB6 RP REC ASSY |
| ANGULAR TOL | ± 1.0° | DRWN: RAJAGN | | 2022/11/28 | | | |
| 4 PLACES | ± 0.01 | CHK'D: YNUKANOBU | | 2022/11/30 | | | |
| 3 PLACES | ± 0.03 | APPR: YNAITO | | 2022/11/30 | | | |
| 2 PLACES | ± 0.05 | INITIAL REVISION: | | DOCUMENT NUMBER | | | |
| 1 PLACE | ± 0.1 | DRWN: TNISHIDA02 | | 5050660000 | | DOC TYPE | |
| 0 PLACES | ± 0.2 | APPR: TKUSUHARA01 | | 2017/03/28 | | DOC PART | |
| DRAFT WHERE APPLICABLE MUST REMAIN WITHIN DIMENSIONS | | THIRD ANGLE PROJECTION | DRAWING | SERIES | MATERIAL NUMBER | CUSTOMER | REVISION |
| | | | A3-SIZE | 505066 | SEE TABLE | GENERAL | E |
| | | | | | | | SHEET NUMBER |
| | | | | | | | 3 OF 3 |

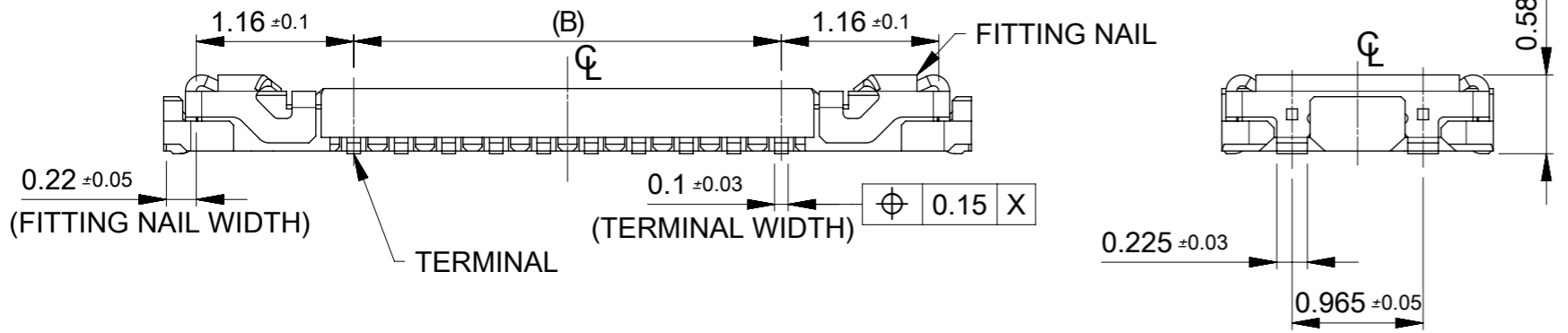
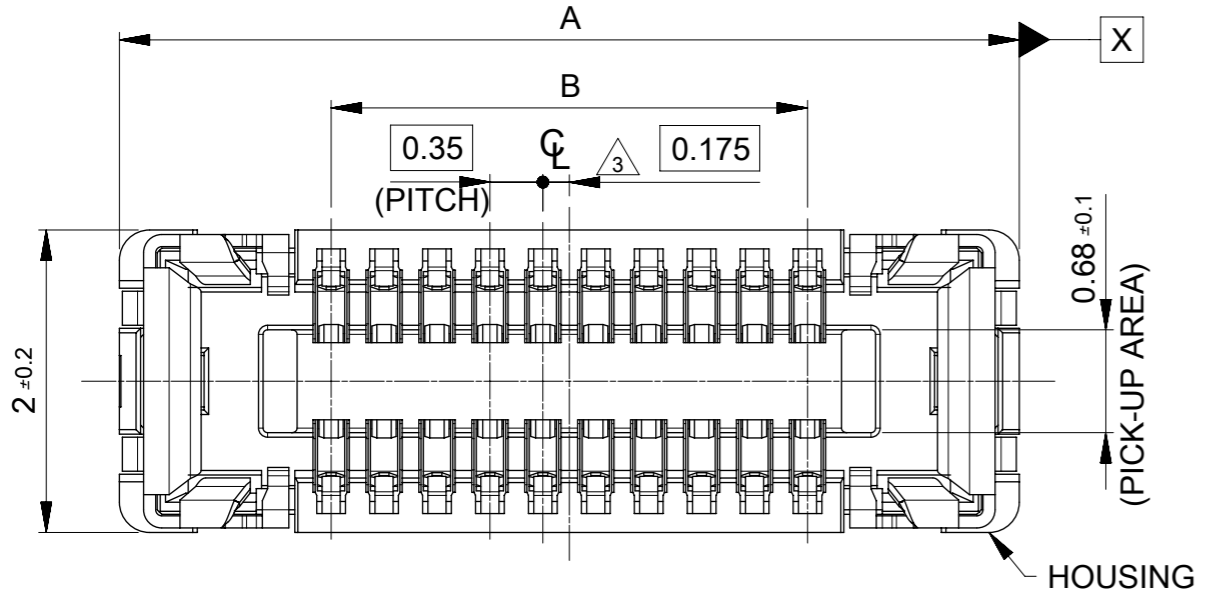

NOTES

- 1 MATERIAL
 WAFER: LIQUID CRYSTAL POLYMER UL94V-0 (COLOR: BLACK)
 TERMINAL: COPPER ALLOY
 FITTING NAIL: COPPER ALLOY
- 2 PLATING
 TERMINAL:
 CONTACT AREA: SEPARATED GOLD PLATING (0.1 MICROMETER MINIMUM).
 SOLDER TAIL AREA: SEPARATED GOLD PLATING.
 UNDERPLATE: NICKEL OVERALL.
 *DIVIDE INTO PARTS THE GOLD PLATING OF THE CONTACT AND THE TAIL PART BY THE NICKEL PLATING.
 FITTING NAIL:
 CONTACT AREA: SEPARATED GOLD PLATING (0.1 MICROMETER MINIMUM).
 SOLDER TAIL AREA: SEPARATED GOLD PLATING.
 UNDERPLATE: NICKEL OVERALL.
 *DIVIDE INTO PARTS THE GOLD PLATING OF THE CONTACT AND THE TAIL PART BY THE NICKEL PLATING.
 *EVEN THOUGH GOLD PLATING ON THE TOP SURFACE OF NAIL MIGHT BE THIN, NO FUNCTIONAL PROBLEM.
- 3 APPLY FOR (CIRCUIT/2)=EVEN.
- 4 MATE WITH : 505070-**22/ 505070-**42
- 5 TAIL AND FITTING NAIL COPLANARITY TO BE 0.08 MAXIMUM.
- 6 PROHIBITED AREA OF PATTERN WIRING AND SOLDER.
 (FOR EACH AREA, THE WIRING THAT TOUCHES ON THE SOLDER CAN BE ATTACHED, THEN COVERED WITH A FILM TO KEEP SOLDER OUT).

| | | | | | |
|-------|-------|-----------------------|--|---------------|---------|
| 11.90 | 14.70 | 505066-7022 | --- | --- | 70 |
| 10.85 | 13.65 | 505066-6422 | --- | --- | 64 |
| 10.15 | 12.95 | 505066-6022 | --- | --- | 60 |
| 9.80 | 12.60 | 505066-5822 | --- | --- | 58 |
| 9.10 | 11.90 | 505066-5422 | ○ | --- | 54 |
| 8.40 | 11.20 | 505066-5022 | ○ | --- | 50 |
| 8.05 | 10.85 | 505066-4822 | ○ | --- | 48 |
| 7.70 | 10.50 | 505066-4622 | --- | --- | 46 |
| 7.00 | 9.80 | 505066-4222 | ○ | --- | 42 |
| 6.65 | 9.45 | 505066-4022 | ○ | --- | 40 |
| 6.30 | 9.10 | 505066-3822 | --- | --- | 38 |
| 5.60 | 8.40 | 505066-3422 | ○ | --- | 34 |
| 5.25 | 8.05 | 505066-3222 | --- | --- | 32 |
| 4.90 | 7.70 | 505066-3022 | ○ | --- | 30 |
| 3.85 | 6.65 | 505066-2422 | ○ | --- | 24 |
| 3.50 | 6.30 | 505066-2222 | ○ | --- | 22 |
| 3.15 | 5.95 | 505066-2022 | ○ | --- | 20 |
| 2.80 | 5.60 | 505066-1822 | --- | --- | 18 |
| 2.45 | 5.25 | 505066-1622 | ○ | --- | 16 |
| 2.10 | 4.90 | 505066-1422 | ○ | --- | 14 |
| 1.75 | 4.55 | 505066-1222 | ○ | --- | 12 |
| 1.40 | 4.20 | 505066-1022 | ○ | --- | 10 |
| 1.05 | 3.85 | 505066-0822 | ○ | --- | 8 |
| 0.70 | 3.50 | 505066-0622 | ○ | --- | 6 |
| B | A | EMBOSSED TAPE PACKAGE | HIGH VOL. TOOL | LOW VOL. TOOL | CIRCUIT |
| | | ORDER NO. | SAMPLE PREPARATION ○ : TOOLED △ : WORK IN PROCESS --- : TOOLING TO BE CONFIRMED | | |

CONNECTOR SERIES No. : 505066-**09

| | | | | | |
|---|---------|------------------------------|---------|-----------------------------|---------|
| THIS DRAWING CONTAINS INFORMATION THAT IS PROPRIETARY TO MOLEX ELECTRONIC TECHNOLOGIES, LLC AND SHOULD NOT BE USED WITHOUT WRITTEN PERMISSION | | CURRENT REV DESC: REVISED | | molex | |
| DIMENSION UNITS | SCALE | EC NO: 612826 | | | |
| mm | 20:1 | DRWN: GSHARMA 2019/02/22 | | 0.35 BB CONN. H=0.6 SSB6 RP | |
| GENERAL TOLERANCES (UNLESS SPECIFIED) | | CHK'D: MSASAO 2019/02/27 | | PRODUCT CUSTOMER DRAWING | |
| ANGULAR TOL | ± 1.0° | APPR: MSASAO 2019/02/27 | | DOCUMENT NUMBER | |
| 4 PLACES | ± 0.001 | INITIAL REVISION: | | 5050661000 | |
| 3 PLACES | ± 0.003 | DRWN: TNISHIDA02 2017/03/28 | | DOC TYPE | |
| 2 PLACES | ± 0.03 | APPR: TKUSUHARA01 2017/04/03 | | PSD | |
| 1 PLACE | ± 0.1 | SERIES | | 016 | |
| 0 PLACES | ± 0.2 | MATERIAL NUMBER | | C | |
| DRAFT WHERE APPLICABLE MUST REMAIN WITHIN DIMENSIONS | | THIRD ANGLE PROJECTION | DRAWING | SHEET NUMBER | 1 OF 2 |
| | | ⊕ | A3-SIZE | 505066 | GENERAL |

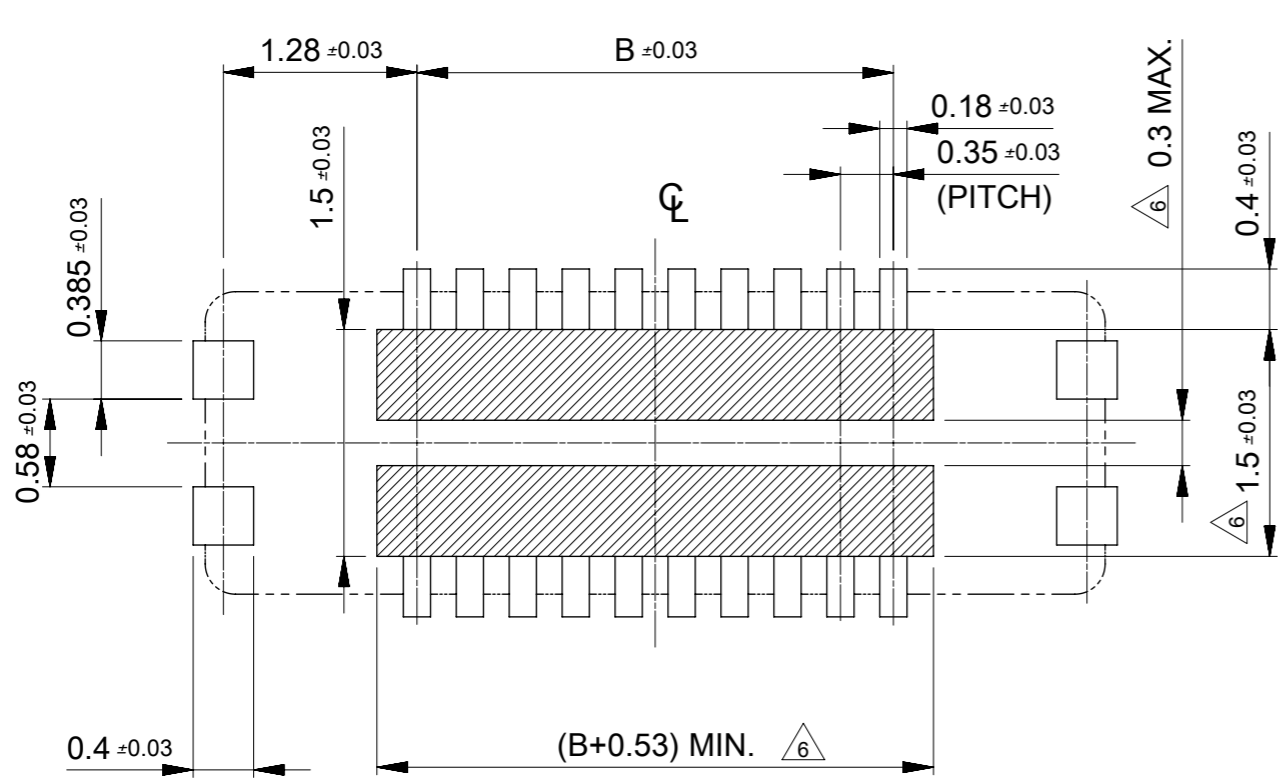

RECOMMENDED P.W. BOARD PATTERN LAYOUT (REFERENCE)

△ 6 PROHIBITED AREA OF PATTERN WIRING AND SOLDER
 (FOR EACH AREA, THE WIRING THAT TOUCHES ON THE SOLDER CAN BE ATTACHED, THEN COVERED WITH A FILM TO KEEP SOLDER OUT)

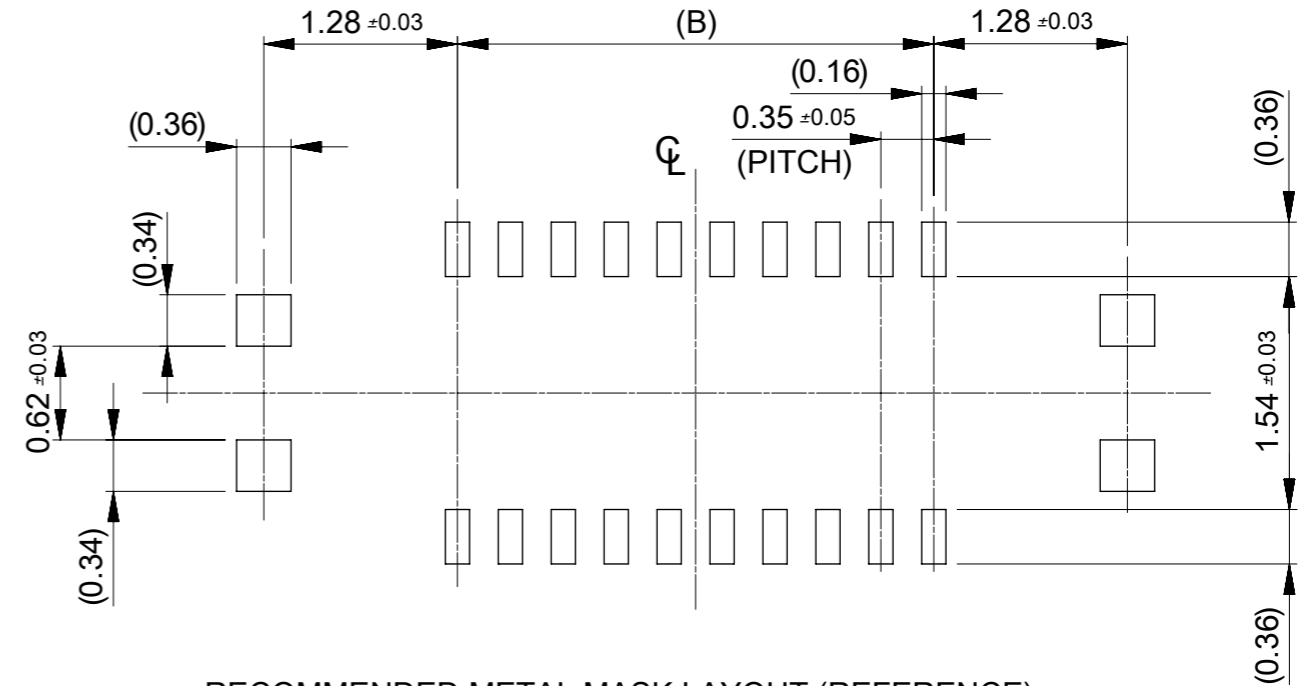

RECOMMENDED METAL MASK LAYOUT (REFERENCE)

RECOMMENDED THICKNESS OF METAL MASK : t=0.08mm

RECOMMENDED OPEN APERTURE RATIO OF METAL MASK : 80%

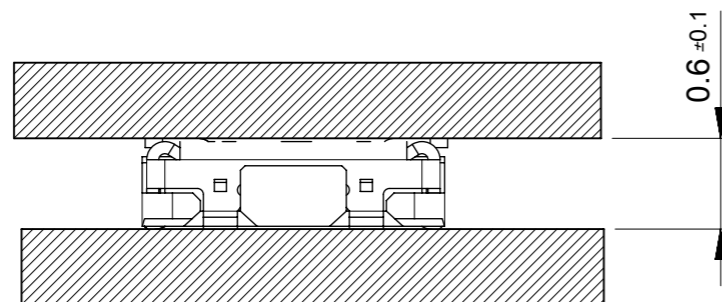

MATED CONDITION

| | | | | | | | | | |
|---|--|------------------------|--|-----------------------------|--|------------------------------|--|----------------------------|--|
| THIS DRAWING CONTAINS INFORMATION THAT IS PROPRIETARY TO MOLEX ELECTRONIC TECHNOLOGIES, LLC AND SHOULD NOT BE USED WITHOUT WRITTEN PERMISSION | | | | | | | | | |
| DIMENSION UNITS mm | | SCALE 20:1 | | CURRENT REV DESC: REVISED | | | | molex | |
| GENERAL TOLERANCES (UNLESS SPECIFIED) | | EC NO: 612826 | | DRWN: GSHARMA 2019/02/22 | | 0.35 BB CONN. H=0.6 SSB6 RP | | | |
| ANGULAR TOL ± 1.0° | | 4 PLACES ± 0.001 | | CHK'D: MSASAO 2019/02/27 | | PRODUCT CUSTOMER DRAWING | | DOCUMENT NUMBER | |
| 3 PLACES ± 0.003 | | 2 PLACES ± 0.03 | | APPR: MSASAO 2019/02/27 | | INITIAL REVISION: | | 5050661000 | |
| 1 PLACE ± 0.1 | | 0 PLACES ± 0.2 | | DRWN: TNISHIDA02 2017/03/28 | | APPR: TKUSUHARA01 2017/04/03 | | DOC TYPE DOC PART REVISION | |
| DRAFT WHERE APPLICABLE MUST REMAIN WITHIN DIMENSIONS | | THIRD ANGLE PROJECTION | | DRAWING | | SERIES | | MATERIAL NUMBER | |
| | | A3-SIZE | | 505066 | | CUSTOMER | | GENERAL | |
| | | | | | | | | SHEET NUMBER | |
| | | | | | | | | 2 OF 2 | |