

10-ohm 0.5%, 1%, 2%, 5% tolerance thick film current sense resistor



features

- RuO₂ thick film resistor element
- Anti-leaching nickel barrier terminations
- Meets or exceeds EIA 575, EIA PDP-100, MIL-R-55342F
- Marking: Three or four digits on indigo protective coat, 1E size: no marking
- Products with lead-free terminations meet RoHS requirements. Pb located in glass material, electrode and resistor element is exempt per Annex 1, exemption 5 of EU directive 2005/95/EC

dimensions and construction

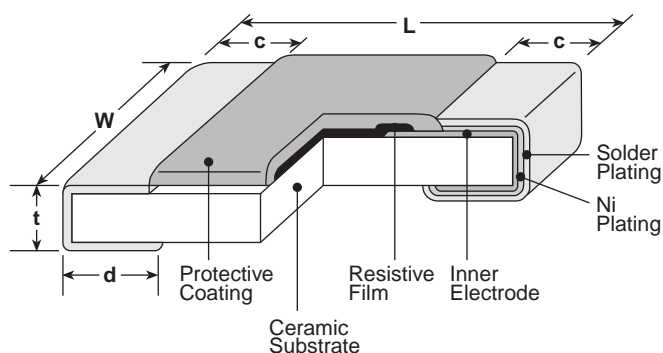

Type (Inch Size Code)	Dimensions inches (mm)				
	L	W	c	d	t
1E (0402)	.039 ^{+0.004} _{-.002} (1.0 ^{+0.1} _{-0.05})	.02 ^{+0.004} _{-.002} (0.5 ^{+0.1} _{-0.05})	.01±.004 (0.25±0.1)	.01±.004 (0.25±0.1)	.014±.002 (0.35±0.05)
1J (0603)	.063±.008 (1.6±0.2)	.031 ^{+0.006} _{-.004} (0.8 ^{+0.15} _{-0.1})	.014±.004 (0.35±0.1)	.014±.004 (0.35±0.1)	.018±.004 (0.45±0.1)
2A (0805)	.079±.008 (2.0±0.2)	.049±.004 (1.25±0.1)	.016±.008 (0.4±0.2)	.012 ^{+0.008} _{-.004} (0.3 ^{+0.2} _{-0.1})	.02±.004 (0.5±0.1)
2B (1206)	.126±.008 (3.2±0.2)	.063±.008 (1.6±0.2)	.02±.012 (0.5±0.3)	.016 ^{+0.008} _{-.004} (0.4 ^{+0.2} _{-0.1})	.024±.004 (0.6±0.1)
2E (1210)		.102±.008 (2.6±0.2)			
2H (2010)	.197±.008 (5.0±0.2)	.098±.008 (2.5±0.2)			
3A (2512)	.248±.008 (6.3±0.2)	.122±.008 (3.1±0.2)			

ordering information

New Part #	SR73	2B	T	TD	1R00	F
Type		Size	Termination Material	Packaging	Nominal Resistance	Tolerance
		1E 1J 2A 2B 2E 2H 3A	T: Sn (Other termination styles may be available, please contact factory for options)	TP: 2mm pitch punched paper (0402, 0603 & 0805) TD: 7" paper tape (0603, 0805, 1206 & 1210) TDD: 10" paper tape (0603, 0805, 1206 & 1210) TE: 7" punched plastic (0805, 1206, 1210, 2010 & 2512) TED: 10" punched plastic (0805, 1206, 1210, 2010 & 2512)	±2%, ±5%: 2 significant figures + 1 multiplier "R" indicates decimal on value <10Ω ±1%: 3 significant figures + 1 multiplier "R" indicates decimal on value <100Ω All values less than 0.1Ω (100mΩ) are expressed in mΩ with "L" as decimal Example: 20mΩ = 20L0	D: ±0.5% F: ±1% G: ±2% J: ±5%

For further information on packaging, please refer to Appendix A.

applications and ratings

Part Designation*	Power Rating @ 70°C	T.C.R. (ppm/°C) Max.	Resistance Range**				Absolute Maximum Working Voltage	Maximum Overload Voltage (5 Secs. Max.)	Operating Temperature Range
			E-24, E-96 (D±0.5%)	E-24, E-96 (F±1%)	E-24 (G±2%)	E-24 (J±5%)			
SR731E (0402)	1/8W (.125W) 1/6W (.166W ²)	±200	—	0.51Ω - 10Ω***	0.51Ω - 10Ω	0.51Ω - 10Ω	1.11V	2.79V	-55°C to +150°C
		±300	—	0.2Ω - 0.47Ω***	0.2Ω - 0.47Ω	0.2Ω - 0.47Ω			
		±500	—	0.1Ω - 0.18Ω***	0.1Ω - 0.18Ω	0.1Ω - 0.18Ω			
SR731J (0603)	1/5W (.2W)	±200	—	0.1Ω - 10Ω	0.1Ω - 10Ω	0.1Ω - 10Ω	1.41V	3.53V	
SR732A (0805)	1/4W (.25W) 1/3W (.33W ²)	±100	0.15Ω - 10Ω	0.1Ω - 10Ω	—	—	1.58V	3.95V	
		±200	—	—	0.1Ω - 10Ω	0.1Ω - 10Ω			
		±500	—	—	—	0.051Ω - 0.091Ω			
		±800	—	—	—	0.030Ω - 0.047Ω			
SR732B (1206)	1/3W (.33W) 1/2W (.5W ²)	±100	0.15Ω - 10Ω	0.1Ω - 10Ω	—	—	1.81V	4.54V	
		±200	—	—	0.1Ω - 10Ω	0.1Ω - 10Ω			
		±500	—	—	—	0.056Ω - 0.091Ω			
		±800	—	—	—	0.030Ω - 0.051Ω			
SR732E (1210)	1/2W (.5W) 2/3W (.66W ²)	±100	—	0.1Ω - 10Ω	—	—	2.23V	5.59V	
		±200	—	—	0.1Ω - 10Ω	0.047Ω - 10Ω			
		±500	—	—	—	0.036Ω - 0.043Ω			
		±1000	—	—	—	0.024Ω - 0.033Ω			
SR732H (2010)	3/4W (.75W)	±100	—	0.1Ω - 10Ω	—	—	2.73V	6.84V	
		±200	—	—	0.1Ω - 10Ω	0.1Ω - 10Ω			
		±500	—	—	—	0.056Ω - 0.091Ω			
		±800	—	—	—	0.033Ω - 0.051Ω			
SR733A (2512)	1W	±100	—	0.1Ω - 10Ω	—	—	3.16V	7.90V	
		±200	—	—	0.1Ω - 10Ω	0.1Ω - 10Ω			
		±500	—	—	—	0.056Ω - 0.091Ω			
		±800	—	—	—	0.039Ω - 0.051Ω			

* Parenthesis indicate EIA package size codes. ** See Appendix D for available decade values. *** 1E (F: ±1%) E-24 values only.

¹ Power Rating for SR731E 0.91Ω - 10Ω = 1/10 (0.1W)

² Please contact factory for limitation of Surface Mount Temp. Rise

environmental applications

Derating Curve

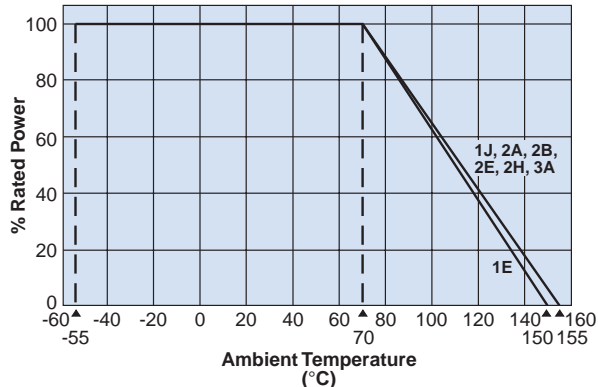

Surface Temperature Rise

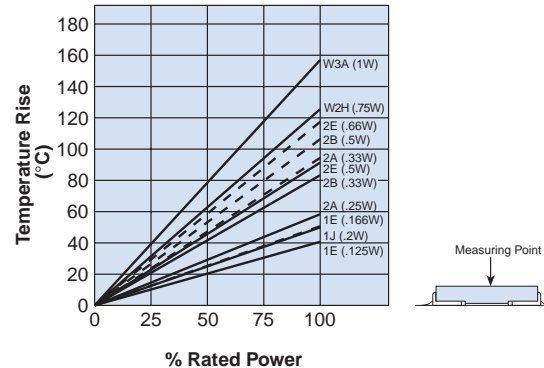

Performance Characteristics

Parameter	Maximum Δ R	Test Method
Thermal Shock	±1.0%	MIL-STD-202, Method 107, -55°C to -150°C, 100 cycles
Low Temperature Operation	±1.0%	MIL-R-55342 π 4.7.4, 1 hour @ -55°C followed by 45 minutes of RCWV*
High Temperature Exposure	±1.0%	MIL-R-55342 π 4.7.6, 100 hours @ -150°C
Short Time Overload	±2.0%	MIL-R-55342 π 4.7.5, 2.5 x RCWV for 5 seconds
Resistance to Solder Heat	±1.0%	MIL-R-55342 π 4.7.7, 260°C for 10 seconds
Terminal Strength-Bend	±1.0%	2mm min. deflection in either direction for 10 seconds
Moisture Resistance	±2.0%	MIL-STD-202, Method 103, 40°C, 90 - 95% RH, 1000 hours
Life	±2.0%	MIL-STD-202, Method 108, 70°C, 1000 hours @ RCWV, 1.5 hr ON, 0.5 hr OFF
Pulse Limitation Curves are available at www.koaspeer.com		
Dielectric Withstanding Voltage 1E, 1J, 2A, 2B, 2E, 2H, 3A	100V, 100V, 400V, 400V, 400V, 400V, 400V	MIL-STD-202, Method 301
Insulation Resistance	10,000 MΩ Minimum	—

* RCWV = Rated Continuous Working Voltage.

Specifications given herein may be changed at any time without prior notice. Please confirm technical specifications before you order and/or use.

10/02/07