

THIS DRAWING IS UNPUBLISHED. RELEASED FOR PUBLICATION
 © COPYRIGHT - By - ALL RIGHTS RESERVED.

REVISIONS				
P	LTR	DESCRIPTION	DATE	APVD
A		REVISED PER ECO-16-018383	14DEC2016	JW SH

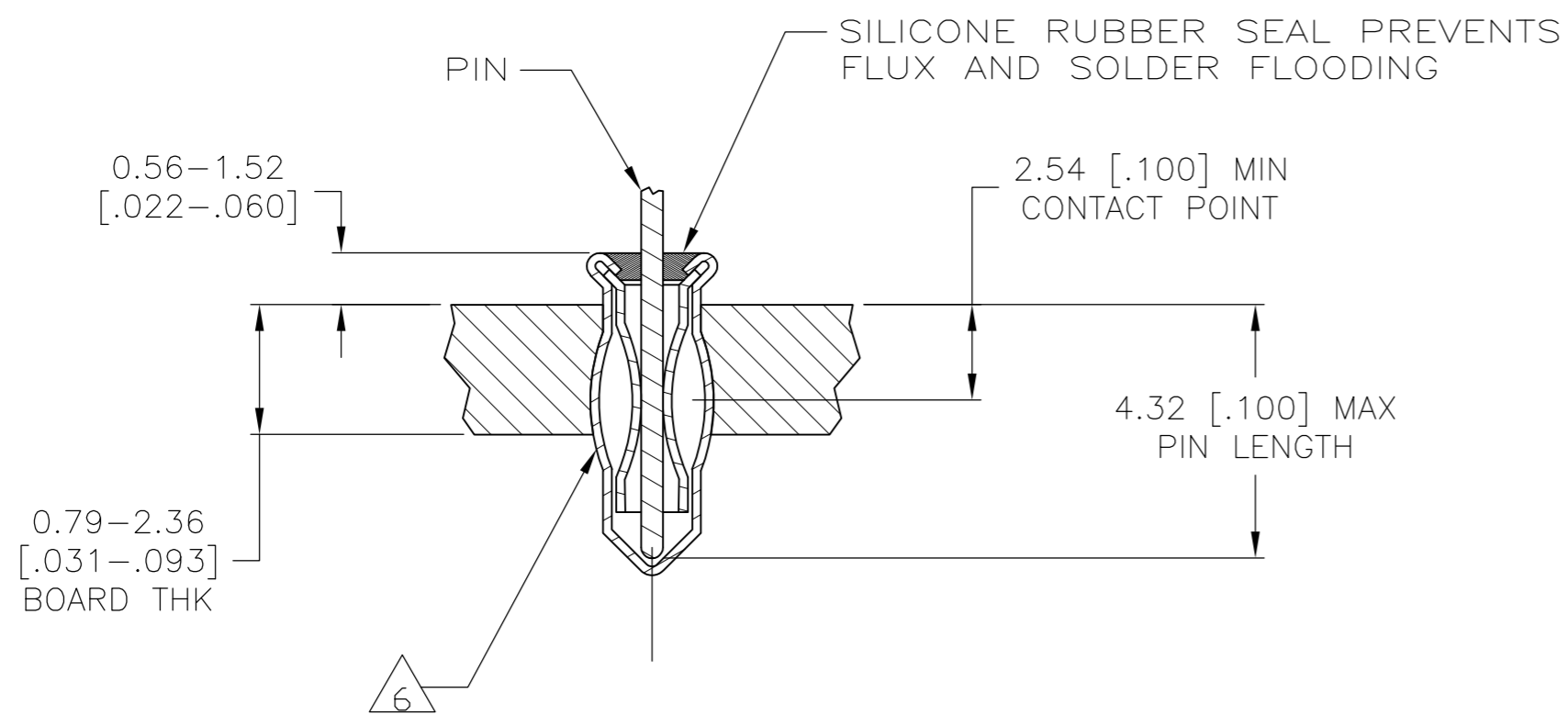
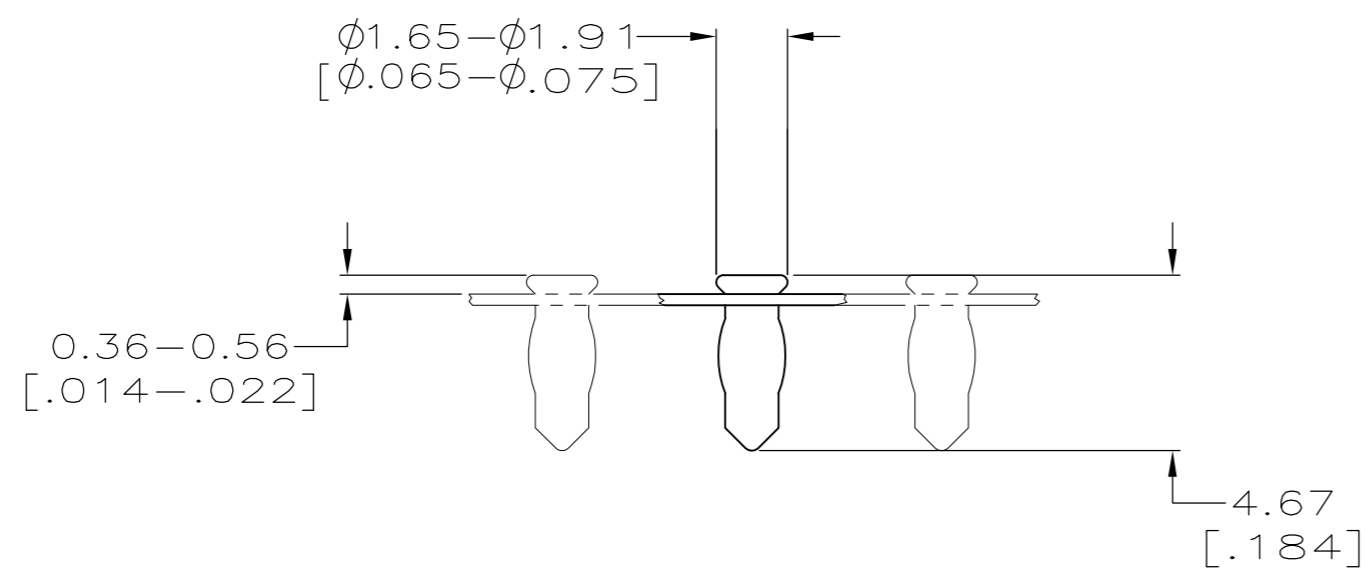
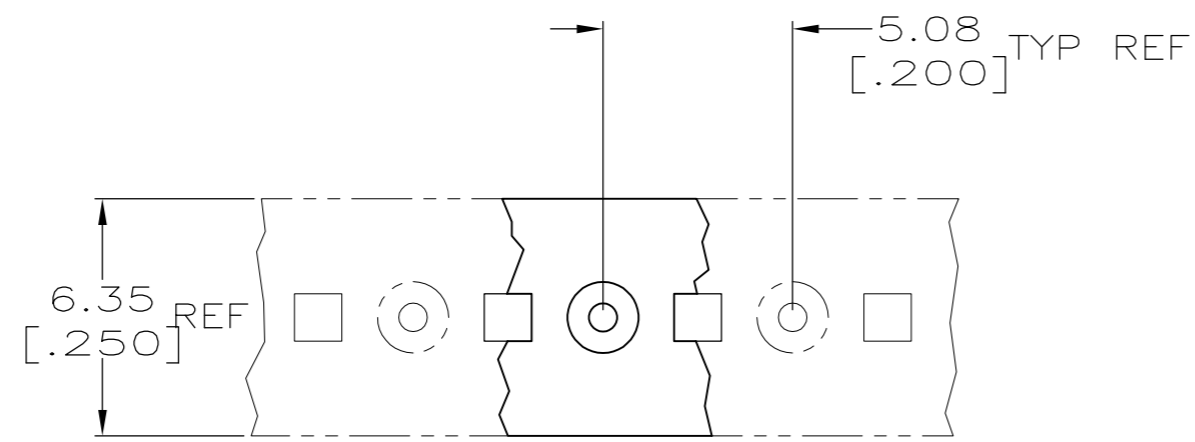

- 1 MATERIAL:
EYELET - COPPER PER ASTM B 152
SPRING - BERYLLIUM COPPER PER ASTM B 194
SEALANT - SILICONE RUBBER
- 2 TIN PLATE PER ASTM B 545, 0.00254 [.000100] MIN THK.
- 3 GOLD PLATE PER ASTM B 488, 0.00076 [.000030] MIN THK ON CONTACT AREA.
- 4 PACKAGED, 50,000 PER REEL
- 5 TO INSURE 1/2 OZ MIN RETENTION DO NOT EXCEED 0.10 [.004] DIFFERENCE IN PIN DIA WHEN CHANGING TO A SMALLER DIA PIN
- 6 PRODUCT IS OVALIZED FOR RETENTION IN THE P.C. BOARD. THE RECOMMENDED HOLE DIAMETER IS 1.32 [0.052] MINIMUM, +0.08 [.003] MAX. PRIOR TO SOLDERING.
- 7 PACKAGED, 10,000 PER REEL
- 8 LOOSE PIECE PACKAGED

2.54-4.32 [.100-.170]	0.36-0.66 [0.014-0.026]	TIN 2	TIN 2	8 2-5645955-1
2.54-4.32 [.100-.170]	0.36-0.66 [0.014-0.026]	GOLD 3	TIN 2	1-5645955-2
2.54-4.32 [.100-.170]	0.36-0.66 [0.014-0.026]	TIN 2	TIN 2	1-5645955-1
2.54-4.32 [.100-.170]	0.36-0.66 [0.014-0.026]	GOLD 3	TIN 2	5645955-2
LENGTH	DIA 5	SPRING	EYELET	PART NO.
PIN		FINISH		

THIS DRAWING IS A CONTROLLED DOCUMENT.		DWN J. POLIGNONE 25JAN06	TE Connectivity			
DIMENSIONS: mm [INCHES]		CHK J. HAVENER 25JAN06				
TOLERANCES UNLESS OTHERWISE SPECIFIED:		APVD J. HAVENER 25JAN06	NAME MINIATURE SPRING SOCKET ASSY SERIES 2 LONG WITH SEALANT			
0 PLC ± -		PRODUCT SPEC 108-14008				
1 PLC ± -		APPLICATION SPEC 114-26004	SIZE A2	CAGE CODE 00779	DRAWING NO C=5645955	RESTRICTED TO -
2 PLC ± -		MATERIAL 1	SCALE 1:1	SHEET 1 OF 1	REV A	
3 PLC ± 0.20[.008]		FINISH SEE TABLE	CUSTOMER DRAWING			
4 PLC ± -						
ANGLES ± A						