

Toggle Switches



Specifications

Electrical:

Maximum contact rating	: Silver : 5 A at 120V AC or 28V DC, 2A at 250V AC, A*
Gold	: 0.4 VA at 20 V (AC or DC), B*
Maximum contact resistance	: 10MΩ
Minimum insulation resistance	: 1,000MΩ at 500V DC
Dielectric strength	: 1,000V RMS

Mechanical:

Life	: 40,000 cycles
------	-----------------

Environmental:

Operating temperature	: -30°C to +85°C
-----------------------	------------------

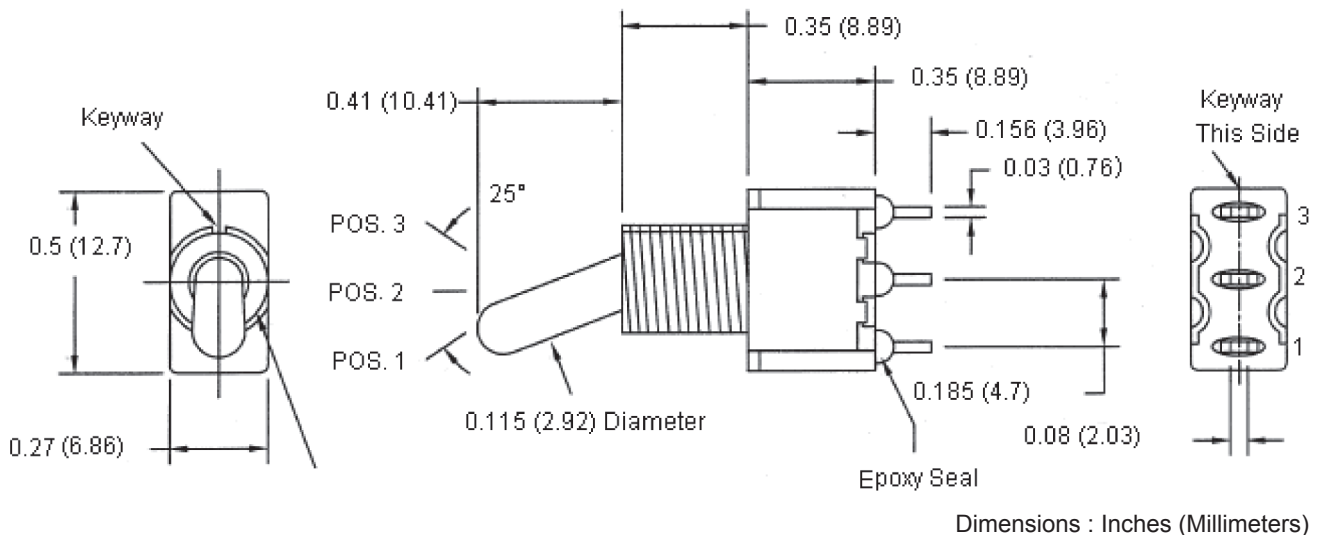

Material:

Case	: DAP
Housing	: Stainless steel
Actuator	: Brass, chrome plated
Bushing	: Brass, nickel plated
Support	: Brass, tin plated
Contact / Terminals	: Copper alloy, silver or gold plated



Toggle Switches

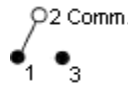

Model No.	Switching Position		
			
SPC21516, SPC21259 SPC21260, SPC21269 SPC21274, SPC21279	On	None	On
SPC21255, SPC21261 SPC21262, SPC21270 SPC21410, SPC21275 SPC21280	On	None	Mom
SPC21256, SPC21263 SPC21264, SPC21271 SPC21276, SPC21281	On	Off	On
SPC21257, SPC21265 SPC21266, SPC21272 SPC21411, SPC21277 SPC21282	Mom	Off	Mom
SPC21258, SPC21267 SPC21268, SPC21273 SPC21278, SPC21283	On	Off	Mom
Conn. Terms	2-3	Open	2-1
Schematic	SPDT 		

For PC Mount Termination Only

PCB Layout
Component Side

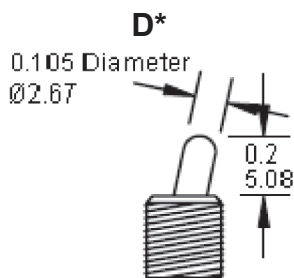
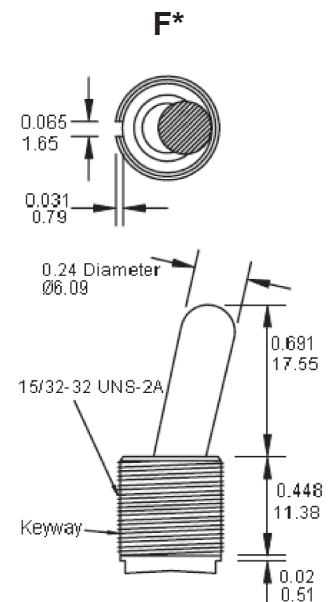
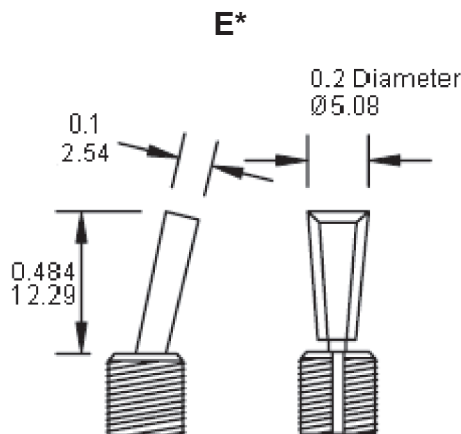
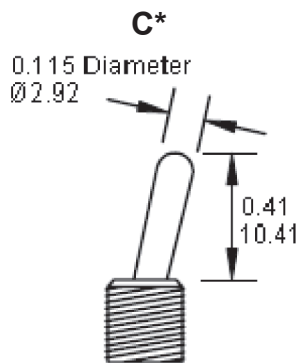
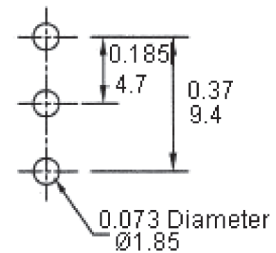

Dimensions : Inches (Millimeters)



Toggle Switches



Bushing Options

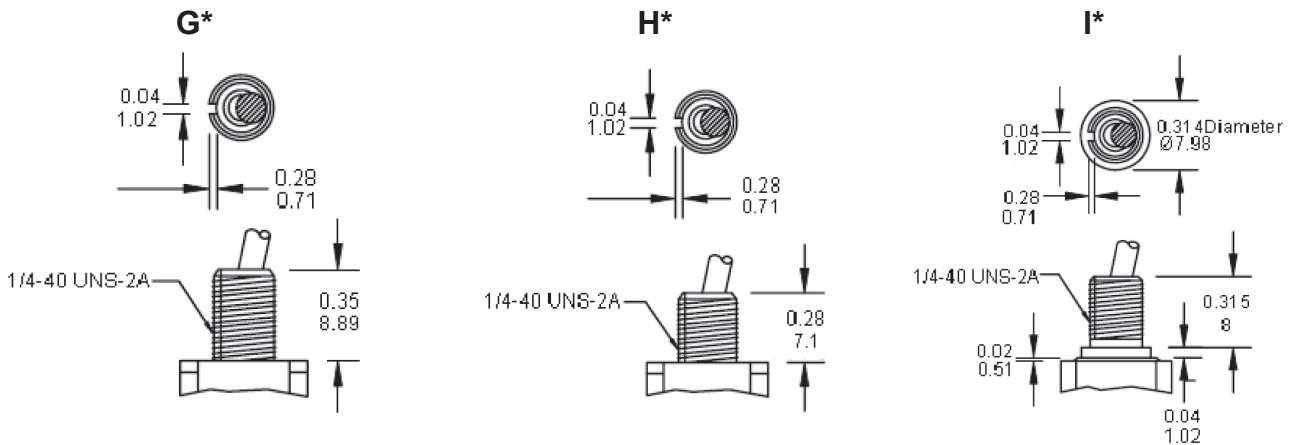

Dimensions : Inches (Millimeters)

Termination Options

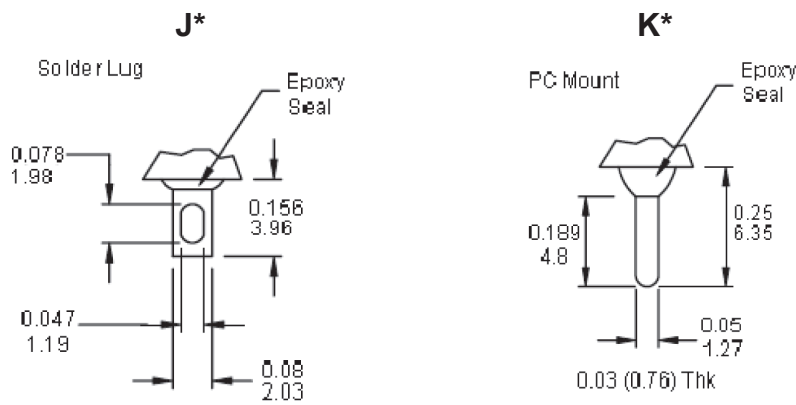

Termination Options

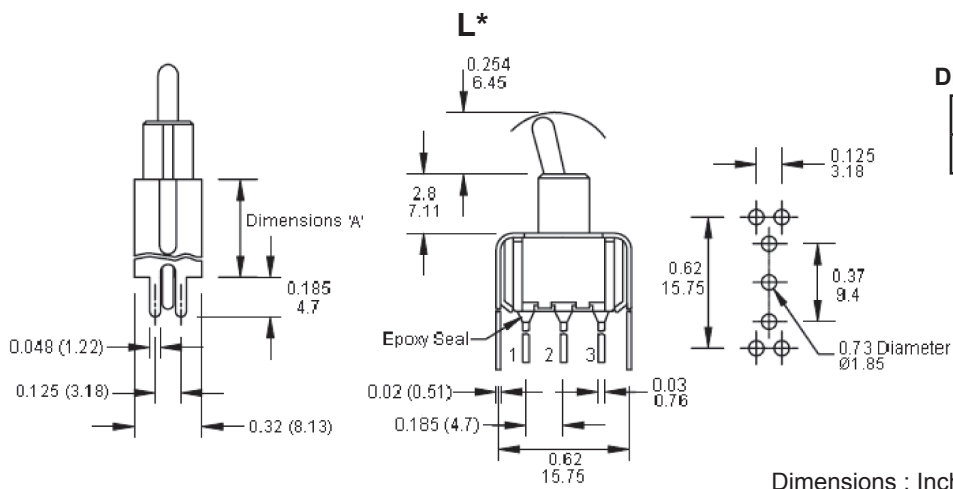

Dimensions : Inches (Millimeters)



Toggle Switches



Standard Nuts

M*

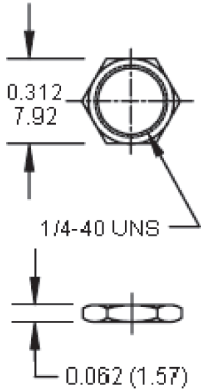

N*

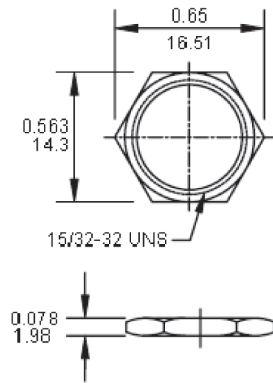

Lock Washer

O*

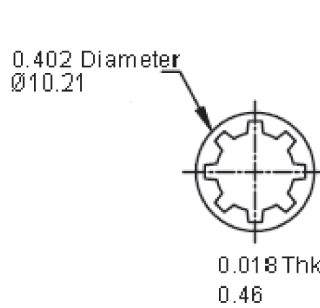

P*

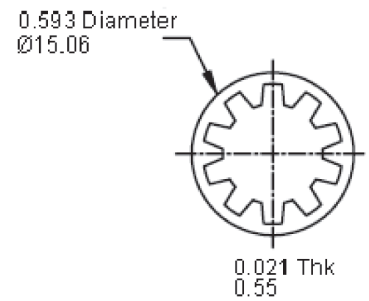

Dimensions : Inches (Millimeters)

Locking Ring

Q*

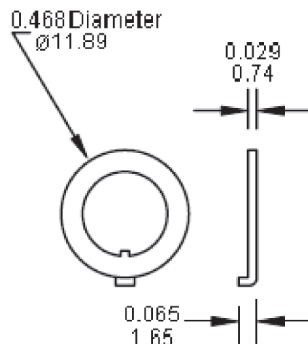

R*

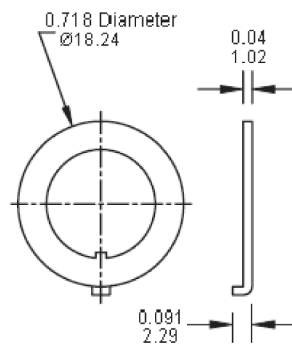

Dimensions : Inches (Millimeters)

Panel Mounting

S*

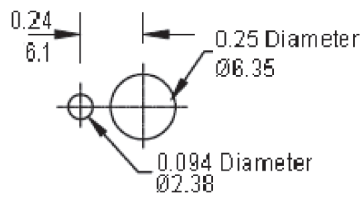
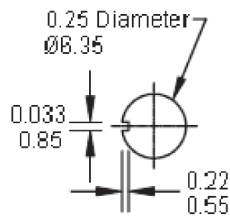

T*

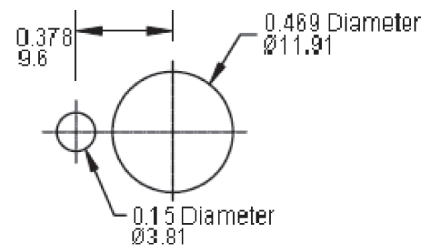
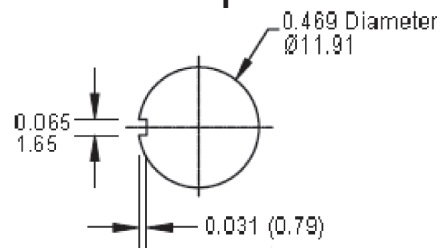

Dimensions : Inches (Millimeters)



Toggle Switches



Part Number Table

Description	Part Number	
Toggle Switch	SPC21255	A*, J*, M*, O*, Q*, S*, C*, G*
	SPC21516	A*, J*, M*, O*, Q*, S*, C*, G*
	SPC21256	A*, J*, M*, O*, Q*, S*, C*, G*
	SPC21257	A*, J*, M*, O*, Q*, S*, C*, G*
	SPC21258	A*, J*, M*, O*, Q*, S*, C*, G*
	SPC21259	A*, K*, M*, O*, Q*, S*, C*, G*
	SPC21260	B*, K*, M*, O*, Q*, S*, C*, G*
	SPC21261	A*, K*, M*, O*, Q*, S*, C*, G*
	SPC21262	B*, K*, M*, O*, Q*, S*, C*, G*
	SPC21263	A*, K*, M*, O*, Q*, S*, C*, G*
	SPC21264	B*, K*, M*, O*, Q*, S*, C*, G*
	SPC21265	A*, K*, M*, O*, Q*, S*, C*, G*
	SPC21266	B*, K*, M*, O*, Q*, S*, C*, G*
	SPC21267	A*, K*, M*, O*, Q*, S*, C*, G*
	SPC21268	B*, K*, M*, O*, Q*, S*, C*, G*
	SPC21269	A*, J*, M*, O*, Q*, S*, E*, G*
	SPC21270	A*, J*, M*, O*, Q*, S*, E*, G*
	SPC21271	A*, J*, M*, O*, Q*, S*, E*, G*
	SPC21272	A*, J*, M*, O*, Q*, S*, E*, G*
	SPC21273	A*, J*, M*, O*, Q*, S*, E*, G*
	SPC21274	A*, J*, L*, P*, R*, T*, N*, F*
	SPC21410	A*, I*, J*, M*, Q*, S*, C*
	SPC21411	A*, I*, J*, M*, Q*, S*, C*
	SPC21275	A*, J*, L*, P*, R*, T*, N*, F*
	SPC21276	A*, J*, L*, P*, R*, T*, N*, F*
	SPC21277	A*, J*, L*, P*, R*, T*, N*, F*
	SPC21278	A*, J*, L*, P*, R*, T*, N*, F*
	SPC21279	B*, H*, K*, Q*, S*, D*
	SPC21280	B*, H*, K*, Q*, S*, D*
	SPC21281	B*, H*, K*, Q*, S*, D*
	SPC21282	B*, H*, K*, Q*, S*, D*
	SPC21283	B*, H*, K*, Q*, S*, D*

Important Notice : This data sheet and its contents (the "Information") belong to the members of the Premier Farnell group of companies (the "Group") or are licensed to it. No licence is granted for the use of it other than for information purposes in connection with the products to which it relates. No licence of any intellectual property rights is granted. The Information is subject to change without notice and replaces all data sheets previously supplied. The Information supplied is believed to be accurate but the Group assumes no responsibility for its accuracy or completeness, any error in or omission from it or for any use made of it. Users of this data sheet should check for themselves the Information and the suitability of the products for their purpose and not make any assumptions based on information included or omitted. Liability for loss or damage resulting from any reliance on the Information or use of it (including liability resulting from negligence or where the Group was aware of the possibility of such loss or damage arising) is excluded. This will not operate to limit or restrict the Group's liability for death or personal injury resulting from its negligence. Multicomp is the registered trademark of the Group. © Premier Farnell plc 2012.

