

AVERY DENNISON MARKETING SPECIFICATION

THE SUBJECT MATTER DISCLOSED HEREIN EMBODIES PROPRIETARY INFORMATION WHICH IS THE CONFIDENTIAL PROPERTY OF THE AVERY DENNISON CO. NONE OF WHICH SHALL BE COPIED, REPRODUCED, DISCLOSED TO OTHERS, PUBLISHED OR USED IN WHOLE OR IN PART, FOR ANY PURPOSE OTHER THAN THAT FOR WHICH IT IS BEING MADE AVAILABLE WITHOUT THE EXPRESS ADVANCE WRITTEN PERMISSION OF A DULY AUTHORIZED AGENT OF THE COMPANY. THIS DOCUMENT IS THE PROPERTY OF THE AVERY DENNISON CO. AND IS TO BE RETURNED TO THE COMPANY ON DEMAND.

HISTORY		DESCRIPTION
REV. H	DATE 06.04.15	REDRAWN IN NEW FORMAT, ADDED UL INFORMATION AND LOGO

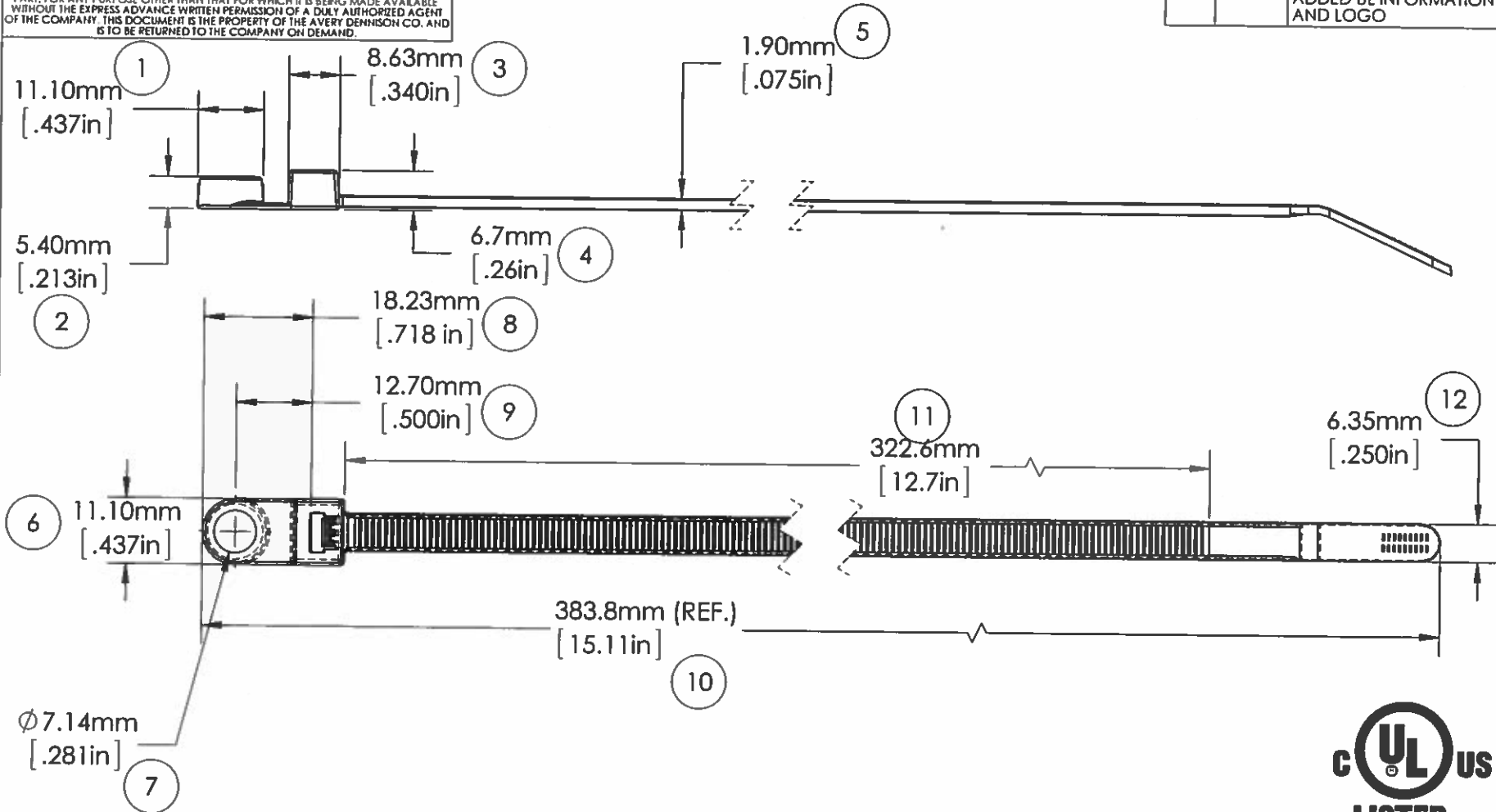

NOTE: THESE CABLE TIES ARE UV RESISTANT AND HAVE A FLAMMABILITY RATING OF V-2



MOUNTING:	1/4" SCREW
LOOP TENSILE STRENGTH:	120 LBF/534 N MIN. PER AS-23190
OPERATING TEMP RANGE:	-40°F (-40°C) TO 176°F (80°C)
MIN. INSTALLATION TEMP:	32°F (0°C)
WEIGHT:	4.89 g. / (0.1663 oz)
BUNDLE DIAMETER:	Ø 26.9mm TO Ø 88.9mm (1.06"-3.5")
TOOL:	TOOL HAND ADJUSTABLE, FOR PLASTIC TIE DOWN STRAP, HEAVY DUTY, PER MS90387-2
TOOL TENSION SETTING:	6-8 ON HEAVY DUTY TOOL
PACKAGING:	100 PACKS IN SEALED BAGS (50 PACKS AVAILABLE)

APPROVALS:	ENG. APPR. <i>[Signature]</i> 06/04/15
	Q.A. APPR. <i>[Signature]</i> 6/4/15

SPECIFIED TOLERANCES ARE:	
.XX ± .03 INCHES	.X ± .7 MM
.XXX ± .010 INCHES	.XX ± .25 MM
ANGULAR: ± 2°	

MATERIAL	NYLON 6/6
COLOR	BLACK, WEATHER RESISTANT

AVERY DENNISON <small>FASTENER DIVISION FITCHBURG, MA 01420 U.S.A. TEL. 1-800-225-5913 FAX. 978-353-8157</small>	DESCRIPTION	STOCK NO.	REV.
	14.5" CABLE TIE, STANDARD 1/4" SCREW MOUNT	10040-0	H

Mouser Electronics

Authorized Distributor

Click to View Pricing, Inventory, Delivery & Lifecycle Information:

[Avery Dennison:](#)

[10040-0](#)