

DATE	DESCRIPTION	REV.

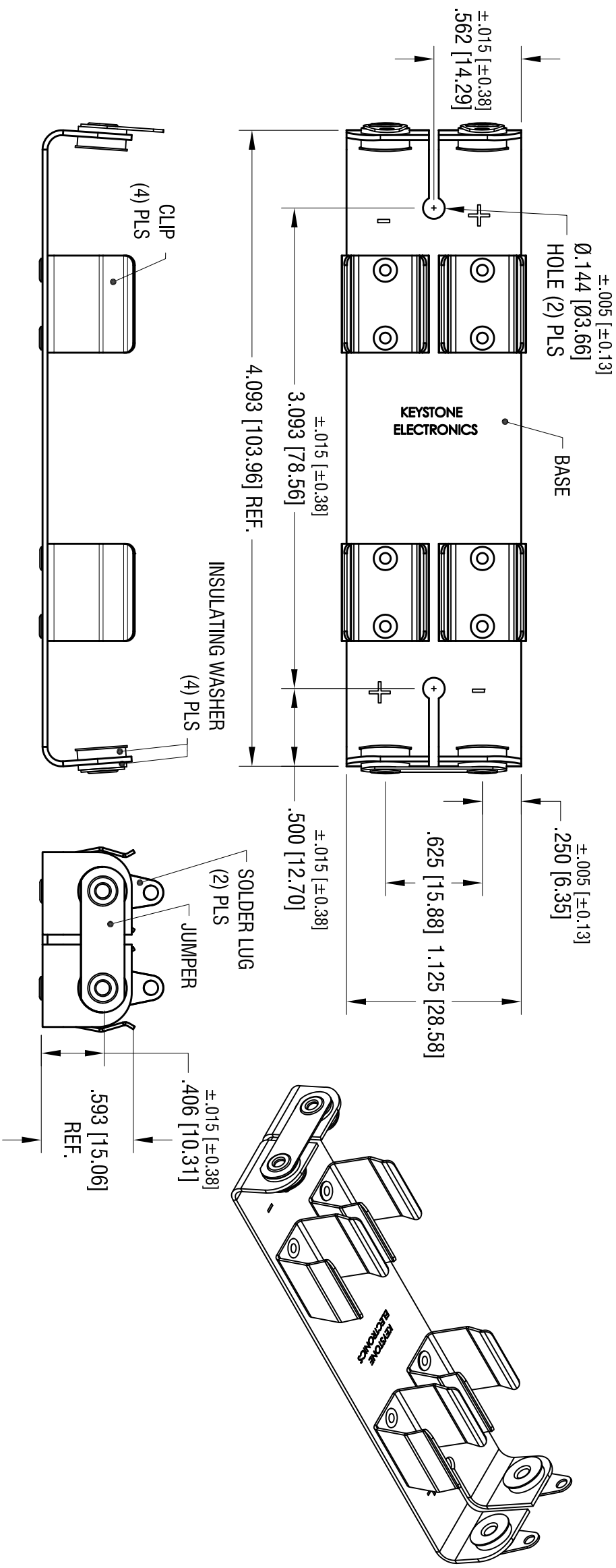

**NOTES:**

1. BASE: MAT'L - .032 [.81] THK ALUMINUM
2. CLIP: MAT'L - .020 [.50] THK ALUMINUM
3. SOLDER LUG: MAT'L - BRASS  
FINISH - TIN PLATE
4. JUMPER: MAT'L - BRASS  
FINISH - TIN PLATE

**KEYSTONE ELECTRONICS CORP.**

www.keystec.com • NEW HYDE PARK, NY 11040 • Tel (516) 328-7500

PART NAME BATTERY HOLDER (4) 'AA'

MATERIAL AS NOTED

FINISH AS NOTED

TOLERANCES	INCH	[MM]	CODE	DWG NO.
DECIMAL	± .010	[± 0.25]	C	148
ANGULAR	± 1°			

THIS DOCUMENT IS THE PROPERTY OF KEYSTONE ELECTRONICS CORP. AND SHALL NOT BE REPRODUCED, DISTRIBUTED OR USED AS A BASIS FOR MANUFACTURE WITHOUT PRIOR WRITTEN PERMISSION FROM KEYSTONE ELECTRONICS CORP.

DRN BY	DATE
BOONE	7.10.07
APP'D	SCALE
RH	1.2X