

# SPECIAL PURPOSE HAND CRIMP TOOL 1716P-1

**DMC** DANIELS  
MANUFACTURING  
CORPORATION  
**DATASHEET**

THIS HAND TOOL MUST NOT BE USED IN ANY POWERED "PRESS" AS DEFINED BY OSHA CFR 1910.211 (46)

SEE REVERSE SIDE FOR IMPORTANT INFORMATION CONCERNING LIMITED WARRANTY, AND LIMITATION OF LIABILITY.

## GENERAL INFORMATION

- \* Model number of tool refers to both the positioner and tool frame as a combined unit.
- \* The tool has a double action ratchet. Note that the tool cannot be opened without completing cycle.

## SPECIFICATIONS

GAGING:		WIRE SIZE:
GO	.073	10-12*
NO-GO	.078	
Contacts:		
M39029/56-527	M39029/58-528	
M39029/106-618	M39029/107-624	
M39029/117-637	M39029/118-649	
M39029/117-643	M39029/118-655	
M39029/121-668	M39029/122-675	
*Recommended to use MS3348-10-12 Crimp Bushing with Size 12 Wire (See AS39029/112 for more info)		

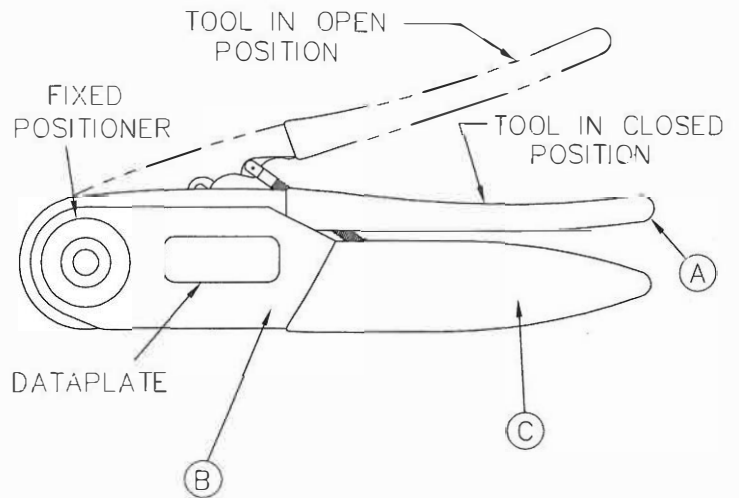

## CRIMPING INSTRUCTIONS

1. With tool in open position, insert contact assembly through indenter opening and into positioner.
2. Squeeze handles together until ratchet releases. Handles will return to open position. Remove crimped contact assembly.

## COLOR CODE

Ⓐ BLUE Ⓑ BLUE Ⓒ BLUE

## GAGING INSTRUCTIONS

### "GO" GAGING

Operate tool to fully closed position. Maintain firm hand pressure on the tool handles. Insert "GO" gage end as shown. Gage must pass freely between indenter tips.

### "NO-GO" GAGING

Operate tool to fully closed position. Maintain firm hand pressure on the tool handles. Insert "NO-GO" gage end as shown. The "NO-GO" gage may partially enter the indenter opening, but must not pass completely through the opening.

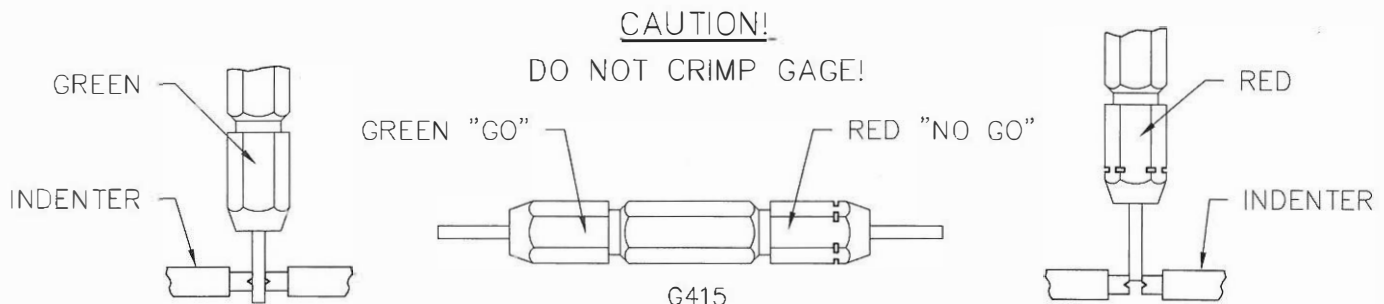

## CARE OF TOOL

It is a good practice to keep indenter tips free of residual color band deposits and other debris. A small wire brush may be used for this purpose.

We strongly recommend that you:

1. DO NOT immerse tools in cleaning solution.
2. DO NOT spray oil into tool to lubricate.
3. DO NOT attempt to disassemble tool or make repairs.

This is a precision hand crimp tool and should be handled as such.

DMC offers complete refurbishing and recalibration services.

DMC specially engineers and manufactures complete tool kits to satisfy individual customer requirements, such as total aircraft support, general shop maintenance or production, on board ship and vehicle service, etc.

## LIMITATION OF LIABILITY

DANIELS MANUFACTURING CORPORATION IS NOT LIABLE FOR CONSEQUENTIAL OR SPECIAL DAMAGES OF ANY NATURE OR KIND RESULTING FROM THE USE, OR MISUSE, OF ANY OF ITS PRODUCTS. OWNERS AND USERS OF DMC PRODUCTS ASSUME FULL RESPONSIBILITY FOR INSTRUCTING THEIR EMPLOYEES IN THE PROPER AND SAFE USE OF SUCH PRODUCTS.

## LIMITED WARRANTY

DMC (Daniels Manufacturing Corporation) warrants each new product sold by it to be free from defects in material and workmanship under normal use and service. DMC's obligation under this warranty is limited to the free correction or, at DMC's option, the refund of the purchase price of any such product which proves defective in normal service within ninety (90) days after delivery to the first user, provided that the product is returned to DMC with all transportation charges prepaid and which shall appear to DMC's satisfaction, after DMC's inspection, to have been defective in material or workmanship, it being understood that DMC products are not consumer products. This warranty shall not cover any damage to any product which, in the opinion of DMC, was caused by normal wear, misuse, improper operation, tampering, neglect or accident. This warranty is in lieu of all other warranties express or implied. No warranty, express or implied, is made or authorized to be made or assumed with respect to products of Daniels Manufacturing Corporation other than those herein set forth.

# Mouser Electronics

Authorized Distributor

Click to View Pricing, Inventory, Delivery & Lifecycle Information:

[Daniels Manufacturing:](#)

[1716P-1](#)