

## RSF124 SERIES

### MINIATURE HORIZONTAL



A miniature horizontal float switch for applications where there is very little space. This short reach switch also has a close differential switch action.

The M12 thread mounting requires access to the inside of the tank, for fitting the switch.

The switch action can be reversed by rotating the device by 180°.

### Features

- Short insertion length (52mm)
- M12 internal mount
- Reversible switch action

## SPECIFICATIONS

### Technical

<b>Material</b>	<b>Stem</b>	Nylon
		<b>Float</b>
<b>Colour</b>		Black/White
<b>Temp. Range</b>	<b>°C</b>	-20/+100
	<b>°F</b>	-4/+212
<b>Min. Fluid SG</b>		0.8
<b>Must Close Level (SG=1)</b>		7mm
<b>Must Open Level (SG=1)</b>		20mm

### Electrical

		25W (Y code)
<b>Contact Form</b>		N/O (N/C)
<b>Switching Power Max</b>	VA	25
<b>Switching Voltage AC Max</b>	V	240
<b>Switching Voltage DC Max</b>	V	120
<b>Switching Current Max</b>	A	0.6

All ratings are for resistive load only.

## STANDARD PARTS

	Stem	Float	Max Power	Leadouts	Gasket
<b>RSF124Y030KC</b>	Nylon	Polypropylene	25VA	30cm AWG22	Nitrile

Custom versions can be made for particular applications. Please contact Sensata with your requirements.



## DIMENSIONS

All dimensions are in millimeters.

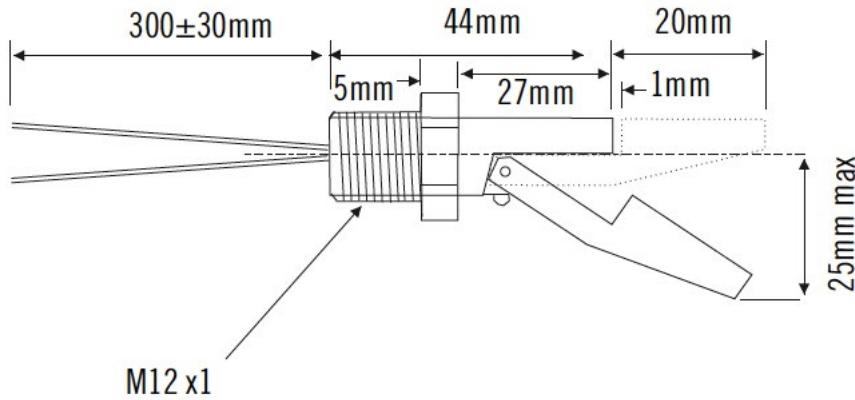

Made in the UK

Page 2

Datasheets provided by Sensata Technologies, Inc., its subsidiaries and/or affiliates ("Sensata") are solely intended to assist third parties ("Buyers") who are developing systems that incorporate Sensata products (also referred to herein as "components"). Buyer understands and agrees that Buyer remains responsible for using its independent analysis, valuation, and judgment in designing Buyer's systems and products. Sensata datasheets have been created using standard laboratory conditions and engineering practices. Sensata has not conducted any testing other than that specifically described in the published documentation for a particular datasheet. Sensata may make corrections, enhancements, improvements, and other changes to its datasheets or components without notice.

Buyers are authorized to use Sensata datasheets with the Sensata component(s) identified in each particular datasheet. HOWEVER, NO OTHER LICENSE, EXPRESS OR IMPLIED, BY ESTOPPEL OR OTHERWISE TO ANY OTHER SENSATA INTELLECTUAL PROPERTY RIGHT, AND NO LICENSE TO ANY THIRD PARTY TECHNOLOGY OR INTELLECTUAL PROPERTY RIGHT, IS GRANTED HEREIN. SENSATA DATASHEETS ARE PROVIDED "AS IS". SENSATA MAKES NO WARRANTIES OR REPRESENTATIONS WITH REGARD TO THE DATASHEETS OR USE OF THE DATASHEETS, EXPRESS, IMPLIED, OR STATUTORY, INCLUDING ACCURACY OR COMPLETENESS. SENSATA DISCLAIMS ANY WARRANTY OF TITLE AND ANY IMPLIED WARRANTIES OF MERCHANTABILITY, FITNESS FOR A PARTICULAR PURPOSE, QUIET ENJOYMENT, QUIET POSSESSION, AND NON-INFRINGEMENT OF ANY THIRD PARTY INTELLECTUAL PROPERTY RIGHTS WITH REGARD TO SENSATA DATASHEETS OR USE THEREOF.

All products are sold subject to Sensata's terms and conditions of sale supplied at [www.sensata.com](http://www.sensata.com). SENSATA ASSUMES NO LIABILITY FOR APPLICATIONS ASSISTANCE OR THE DESIGN OF BUYERS' PRODUCTS. BUYER ACKNOWLEDGES AND AGREES THAT IT IS SOLELY RESPONSIBLE FOR COMPLIANCE WITH ALL LEGAL, REGULATORY, AND SAFETY-RELATED REQUIREMENTS CONCERNING ITS PRODUCTS, AND ANY USE OF SENSATA COMPONENTS IN ITS APPLICATIONS, NOTWITHSTANDING ANY APPLICATIONS-RELATED INFORMATION OR SUPPORT THAT MAY BE PROVIDED BY SENSATA.

Mailing Address: Sensata Technologies, Inc., 529 Pleasant Street, Attleboro, MA 02703, USA

## CONTACT US

+44 (0)1202 897969  
 support@sensata.com  
 Cynergy3 Components Ltd.  
 7 Cobham Road,  
 Ferndown Industrial Estate,  
 Wimborne, Dorset,  
 BH21 7PE, United Kingdom