

# RC880

## RC880 Data Sheet



### Introduction

When using a regulated power supply for a drive, it is very likely that regenerative energy will cause problems when rapidly decelerating a load from a high speed. Under these conditions, the kinetic energy of that load is transferred back through the drive electronics to the power supply connection. This increase in voltage can trip the overvoltage protection of a switching power supply, causing it to shut down. The RC880 regeneration clamp is designed to solve this problem by absorbing the regenerated energy in a capacitor and shunting the excess energy through a power resistor.

Knowing the inertia of the system, along with the change in speed and the time required to decrease speed, will allow for the regenerated power to be calculated. If in doubt, it is a good idea to use the RC880 for test purposes in the first installation. If the “regen” LED on the RC880 never flashes, you may not need the clamp.



Electrical Specifications				
Parameter	Min.	Typ.	Max.	Unit
Power Supply voltage	-	-	80	VDC
Input Current (RMS)	-	-	15	Amps
Output Current (RMS)	7.0(max)/Channel, but no more than 15(max) total			Amps
Clamp circuit activation Voltage	1	1.3	1.6	V (Vout-Vin)
Clamp circuit inactivation Voltage	0.3	0.5	0.7	V (Vout-Vin)
Capacitance	-	3000	-	μF
Resistance	9.9	10	10.1	Ω
Continuous Power Dissipation	-	50	-	W
Peak Power Dissipation	-	800	-	W

Environmental Specifications	
Heat Sinking Method	Natural cooling or fan-forced cooling
Surrounding Air Conditions	Avoid dust, oily mist and corrosive air
Operating Temperature	0 - 40 °C (32 - 104 °F)
Maximum Ambient Humidity	90% non-condensing
Shock	5.9m/s <sup>2</sup> maximum
Storage Temperature	-10 - 70 °C (14 - 158 °F)

**LED Status**  
The RC880 has two LEDs to indicate status. Power is ON when the green LED is solid. The red LED indicates clamp (or shunt) circuit activation.

LED	Status
	Solid
	Flashing or Solid

## Connections

Connect the power supply “V+” terminal to the RC880 terminal labeled “Vin+” and the power supply “V-” terminal to the RC880 terminal labeled “Vin-”. Then, connect the RC880 terminal labeled “Vout+” to the drive terminal “V+” and the RC880 terminal labeled “Vout-” to the drive terminal “V-”. The RC880 has a maximum of 3 channels to allow for connecting up to 3 drives.

Use AWG18 or AWG20 wires for connection.

**BE CAREFUL NOT TO REVERSE THE WIRES.**

**A REVERSE CONNECTION WILL DESTROY YOUR DRIVE.**

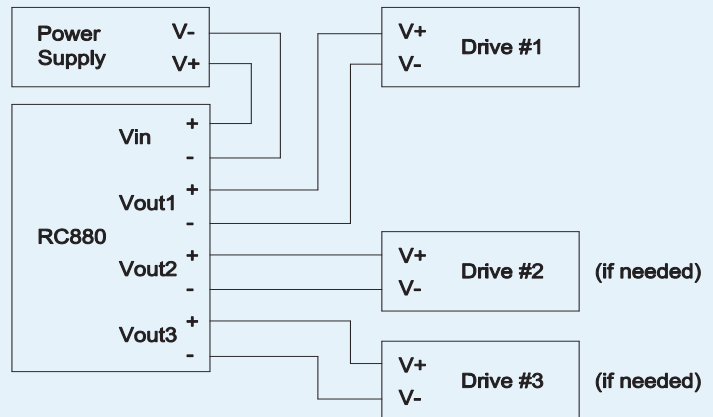
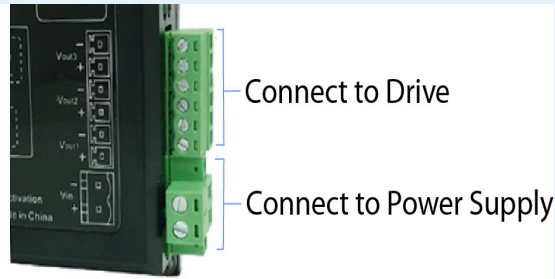

WIRING DIAGRAM

### MECHANICAL OUTLINE (mm)

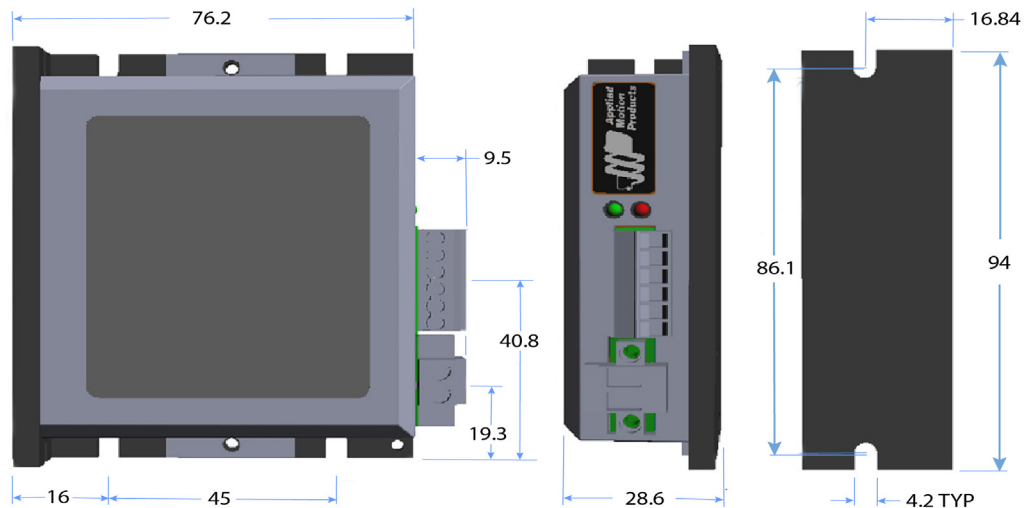

If you have any questions or comments, please call Applied Motion Products Customer Support: (800) 525-1609, or visit us online at [www.applied-motion.com](http://www.applied-motion.com).



404 Westridge Dr.

Watsonville, CA 95076

Tel: 800-525-1609

Fax: 831-761-6544

[www.applied-motion.com](http://www.applied-motion.com)

**RC880 Data Sheet**

925-0018 Rev A

Sht 2 of 2

# Mouser Electronics

Authorized Distributor

Click to View Pricing, Inventory, Delivery & Lifecycle Information:

[Applied Motion:](#)

[RC880](#)