



RS-232 and RS-485 X2-Series Expansion Board

March 2024

Revision 001

X2BS10X43 RS-232 and RS-485 X2-Series Expansion Board



Safety information	4
Qualified personnel	4
Hazard levels	4
Safety instructions	5
General safety instructions	5
Introduction	6
Features	7
Device identification	8
Hardware setup	9
Connections	9
Power and status LEDs	9
Using the RS-232 and RS-485 expansion board	10
RS-232 serial port	10
RS-485 serial port	10
Software configuration and usage	12
I ² C Configuration and control registers map	13
Block diagram	14
Technical specifications	15
Dimensions	16
Disposal	17
Installation and use restrictions	17
Standards and regulations	17
Safety instructions	17
Set-up	17
Conformity Information	18
EU	18
USA	18
CANADA	19
RCM AUSTRALIA / NEW ZEALAND	19

Before opening the Strato Pi Max enclosure, disconnect all power sources and any connection to external devices, including USB and Ethernet cables.

Follow all applicable electrical safety standards, guidelines, specifications and regulations for installation, wiring and operations of Strato Pi Max.

Carefully and fully read this Strato Pi Max user guide before installation.

Strato Pi Max is not authorised for use in safety-critical applications where a failure of the product would reasonably be expected to cause personal injury or death. Safety-critical applications include, without limitation, life support devices and systems, equipment or systems for the operation of nuclear facilities and weapons systems. Strato Pi Max is neither designed nor intended for use in critical military or aerospace applications or environments and for automotive applications or environment. Customer acknowledges and agrees that any such use of Strato Pi Max is solely at Customer's risk, and that Customer is solely responsible for compliance with all legal and regulatory requirements in connection with such use.

Sfera Labs S.r.l. may make changes to specifications and product descriptions at any time, without notice. The product information on the web site or materials is subject to change without notice.

Please download and read the Sfera Labs Terms and Conditions document available at:

<http://www.sferalabs.cc>

Strato and Sfera Labs are trademarks of Sfera Labs S.r.l. Other brands and names may be claimed as the property of others.

Copyright © 2024 Sfera Labs S.r.l. All rights reserved.

Safety information

Carefully and fully read this user guide before installation and retain it for future reference.

Qualified personnel

The product described in this manual must be operated only by personnel qualified for the specific task and installation environment, in accordance with all relevant documentation and safety instructions. A qualified person should be capable of fully identifying all installation and operation risks and avoid potential hazards when working with this product.

Hazard levels

This manual contains information you must observe to ensure your personal safety and prevent damage to property. Safety information in this manual are highlighted by the safety symbols below, graded according to the degree of danger.



Indicates a hazardous situation which, if not avoided, **will** result in death or serious personal injury.



Indicates a hazardous situation which, if not avoided, **may** result in death or serious personal injury.



Indicates a hazardous situation which, if not avoided, can result in minor or moderate personal injury.



Indicates a situation which, if not avoided, can result in damage of property.

Safety instructions

General safety instructions

Protect the unit against moisture, dirt and any kind of damage during transport, storage and operation. Do not operate the unit outside the specified technical data.

Never open the housing. If not otherwise specified, install in closed housing (e.g. distribution cabinet). Earth the unit at the terminals provided, if existing, for this purpose. Do not obstruct cooling of the unit. Keep out of the reach of children.



Life threatening voltages are present within and around an open control cabinet.

When installing this product in a control cabinet or any other areas where dangerous voltages are present, always switch off the power supply to the cabinet or equipment.



Risk of fire if not installed and operated properly.

Follow all applicable electrical safety standards, guidelines, specifications and regulations for installation, wiring and operations of this product.

The expansion board could generate a substantial amount of heat, particularly when subject to a significant amount of electrical load.



The connection of expansion devices to this product may damage the product and other connected systems, and may violate safety rules and regulations regarding radio interference and electromagnetic compatibility.

Use only appropriate tools when installing this product. Using excessive force with tools may damage the product, alter its characteristics or degrade its safety.

Introduction

The X2-Series X2BS10X43 RS-232 and RS-485 expansion board provides one galvanically isolated RS-485 serial port and one RS-232 serial port with hardware flow control. Both ports are interfaced to the Compute module via an integrated FTDI FT2232HQ Hi-speed USB 2.0 Slave to Dual Channel UART / Serial Converter.

This manual generally refers to Strato Pi Max XL and Strato Pi Max XS as Strato Pi Max.

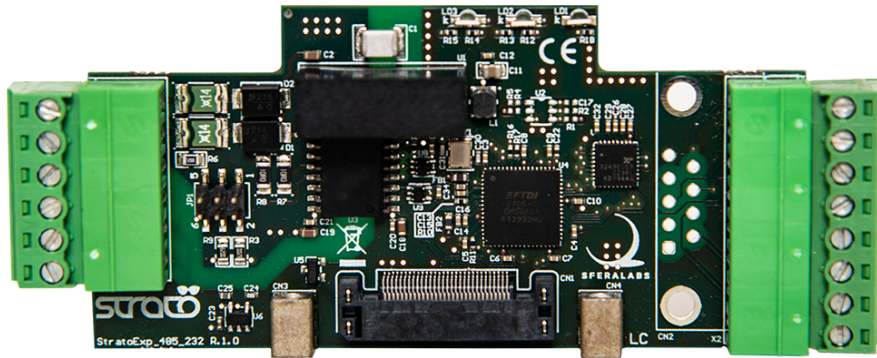

X2BS10X43 RS-232 AND RS-485 X2-SERIES EXPANSION BOARD

Features

- ✓ standard RS-232 interface with hardware flow-control support and electrostatic discharge protection, up to 115.200 bps
- ✓ standard RS-485 interface, with opto-isolator and electrostatic discharge protection, up to 115.200 bps
- ✓ Configurable local TX/RX echo on the RS-485 interface
- ✓ front panel LEDs show board power supply, RS-232 RX and TX activity, RS-485 RX and TX activity.

Device identification

The circuit board is identified by the "**StratoExp_485_232 R.1.0**" markings on the lower left corner of the circuit board (front view). One or more alphanumeric characters may be printed after the version number.

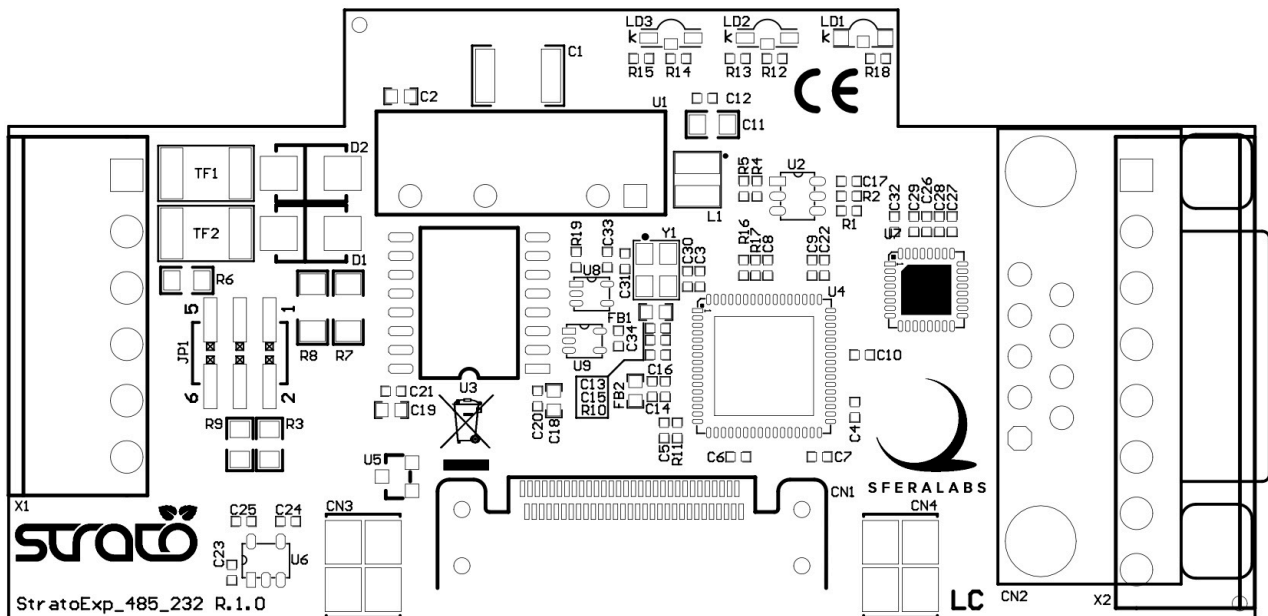

CIRCUIT BOARD IDENTIFICATION MARKINGS

Hardware setup

Connections

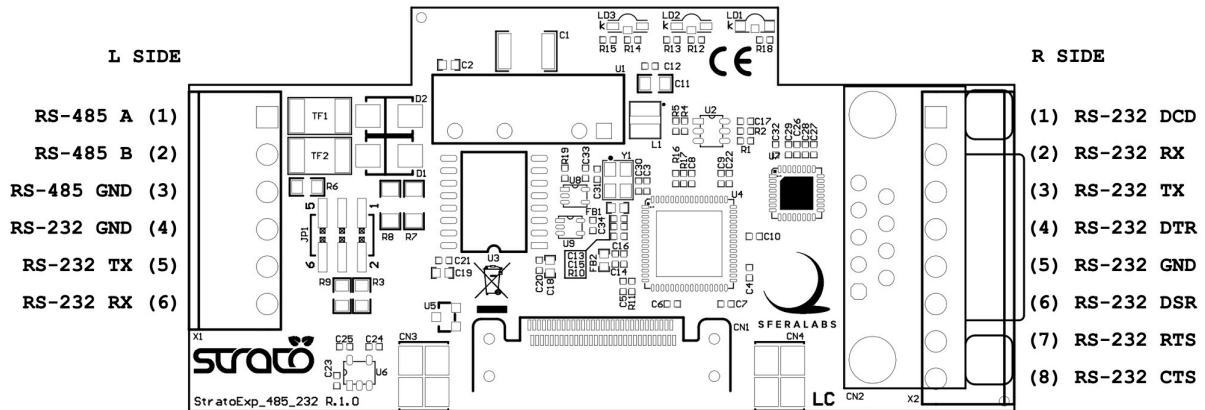

TERMINAL BLOCKS CONNECTIONS

In order to install or remove the expansion board, the plastic DIN rail enclosure must be removed

NOTICE

Before opening the Strato Pi Max enclosure, disconnect all power sources and any connection to external devices, including USB and Ethernet cables.

Follow the Strato Pi Max User Guide installation instructions.

This expansion board must be installed in any slot, and up to 4 boards can be fitted in Strato Pi Max XL.

Carefully align the board-to-board connectors and gently push the board in place. Note that the connectors could be damaged if not properly aligned during insertion or removal.

Use the two screws provided with the expansion board to lock the board in place.

Power and status LEDs

This expansion board has three LEDs, visible through the front panel:

- A. Blue: on when the expansion board is powered
- B. Red: RS-485 RX activity. Green: RS-485 TX activity
- C. Red: RS-232 RX activity. Green: RS-232 TX activity.

Using the RS-232 and RS-485 expansion board

RS-232 serial port

This expansion board provides one RS-232 serial port with hardware flow control. The serial port is interfaced to the Compute module via an integrated FTDI FT2232HQ Hi-speed USB 2.0 Slave to Dual Channel UART / Serial Converter.

For convenience, the RX, TX and RS-232 GND lines are available on both terminal blocks. The hardware flow control lines are only available on the H-side terminal block.

RS-485 serial port

This expansion board provides one galvanically isolated RS-485 serial port. The serial port is interfaced to the Compute module via an integrated FTDI FT2232HQ Hi-speed USB 2.0 Slave to Dual Channel UART / Serial Converter.

The RS-485 port is galvanically isolated using a dedicated isolated differential line transceiver and a high-efficiency DC-DC converter. This configuration should prevent ground loops between devices connected through this port.

The RS-485 GND terminal is the isolated ground reference for the RS-485 serial lines. Always use this line, not RS-232 GND, for the RS-485 connection.

The RS-485 TX/RX switching is implemented automatically in the FT2232HQ, and is completely transparent to the software on Raspberry Pi.

Local echo of transmitted data can be enabled or disabled (default) via the RP2040.

The RS-485 line has 620 Ohm pull-up and pull-down resistors on lines A and B. The biasing resistors ensure that, during idle periods the data lines are kept at a stable voltage level and prevent false triggering of receiver input. These resistors can be disabled by removing jumpers JP1A and JP1B respectively.

A 100 Ohm termination resistor between A and B is connected when the JP1C jumper is inserted.

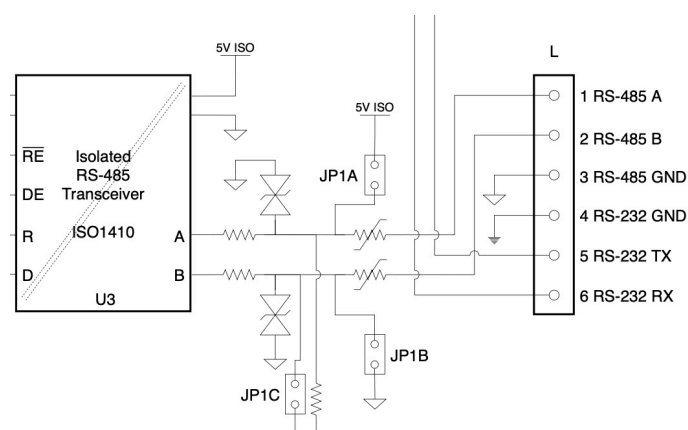

RS-485 JUMPERS SCHEMATIC

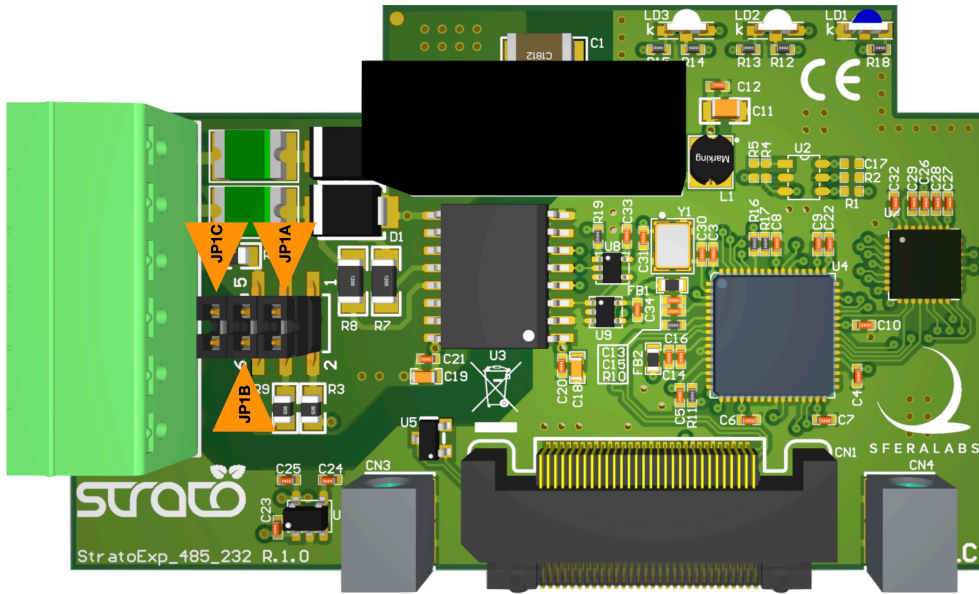

RS-485 JUMPERS POSITION

Software configuration and usage

All features of the expansion board can be used with any operating system for which standard FTDI drivers¹ are provided.

On Linux the drivers emulate a standard serial port for each of the two (RS-232 and RS-485) interfaces, available under the path `/dev/ttyUSB<n>`. Enumeration order is not guaranteed within the Linux kernel, therefore, to add static paths to each interface on each installed expansion board, the 'udev' device manager shall be used.

Following is an example udev configuration.

Create a file named `99-x2-232-485-ftdi.rules` in `/etc/udev/rules.d/` with the following content:

```
SUBSYSTEMS=="usb", KERNEL=="ttyUSB[0-9]*", ATTRS{interface}=="Dual RS232-HS",
ATTRS{bInterfaceNumber}=="00", SYMLINK+="x2-rs485-%b"
```

```
SUBSYSTEMS=="usb", KERNEL=="ttyUSB[0-9]*", ATTRS{interface}=="Dual RS232-HS",
ATTRS{bInterfaceNumber}=="01", SYMLINK+="x2-rs232-%b"
```

Reload the systems udev rules:

```
$ sudo udevadm control --reload-rules && udevadm trigger
```

The following device paths will become available.

Expansion slot 1:

```
/dev/x2-rs485-1-1.5.4:1.0
/dev/x2-rs232-1-1.5.4:1.1
```

Expansion slot 2:

```
/dev/x2-rs485-1-1.5.3:1.0
/dev/x2-rs232-1-1.5.3:1.1
```

Expansion slot 3:

```
/dev/x2-rs485-1-1.5.2:1.0
/dev/x2-rs232-1-1.5.2:1.1
```

Expansion slot 4:

```
/dev/x2-rs485-1-1.5.1:1.0
/dev/x2-rs232-1-1.5.1:1.1
```

The RS-485 local echo configuration can be enabled via I²C as described below.

¹ <https://ftdichip.com/drivers/>

I²C Configuration and control registers map

Installing one or more RS-232 and RS-485 Expansion Boards on Strato Pi Max adds the following registers to its I²C map.

ADDR	BYTE 1								BYTE 0							
	15	14	13	12	11	10	9	8	7	6	5	4	3	2	1	0
89													ECHO 4	ECHO 3	ECHO 2	ECHO 1

Register 89 (RW)

- Bit 1 **ECHO1**: Slot 1 RS-485 local echo control
 0 = disabled (default)
 1 = enabled
- Bit 2 **ECHO2**: Slot 2 RS-485 local echo control
 0 = disabled (default)
 1 = enabled
- Bit 3 **ECHO3**: Slot 3 RS-485 local echo control
 0 = disabled (default)
 1 = enabled
- Bit 4 **ECHO4**: Slot 4 RS-485 local echo control
 0 = disabled (default)
 1 = enabled

Block diagram

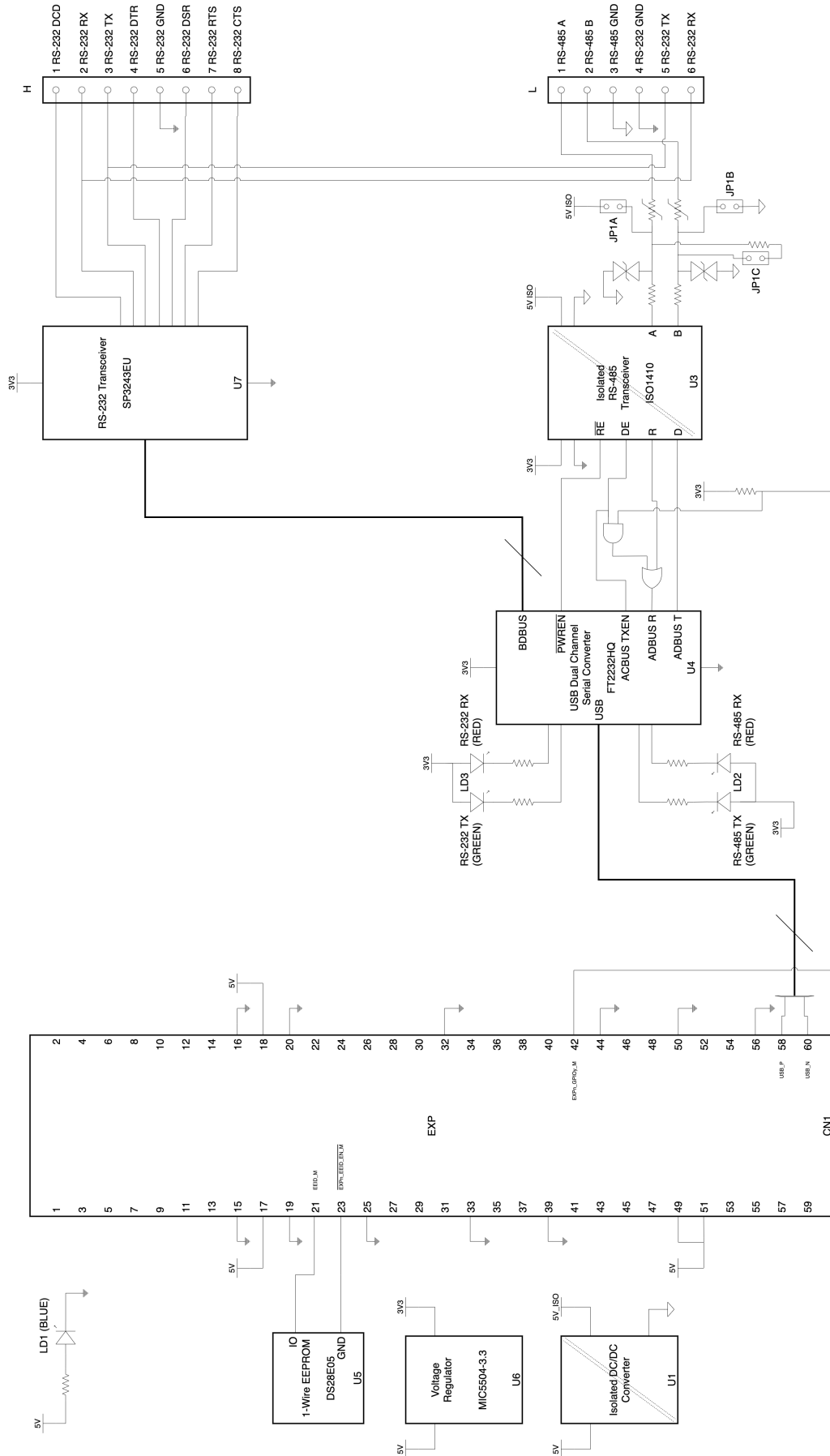

SFERA LABS SRL - X2BS10X43 V.1.0 BLOCK DIAGRAM R.02 - 15 MAR 2024 - COPYRIGHT 2024 SFERA LABS SRL ITALY ALL RIGHTS RESERVED

Technical specifications

Note: all values typical, at +25 °C and under normal operating conditions.

COMMUNICATION PORTS	
Serial communication ports	RS-485 Half-Duplex with automatic data direction management RS-232 Full-Duplex, with hardware flow control
Baud rates on COMM ports	1200 to 115200
ESD protection on RS-232 TX/RX	±15 kV human body model ±8 kV contact discharge
ESD protection on RS-485 A/B	±30 kV human body model ±16 kV IEC 61000-4-2 contact discharge ±4 kV IEC 61000-4-4 fast transients
EMI IMMUNITY STANDARDS	
Electromagnetic immunity compliance	EN 61000-4-2 (ESD) EN 61000-4-3 (Radiated RF Field) EN 61000-4-4 (Burst/fast transient) EN 61000-4-5 (Surge) EN 61000-4-6 (Conducted) EN 61000-4-8 (Power frequency magnetic field)
ENVIRONMENTAL	
Operating temperature	-20...+60 °C
Storage temperature	-30...+80 °C
Altitude	Up to 2000 m
Humidity	5% to 95% RH noncondensing
Protection degree	IP20
MECHANICAL	
3.81 mm pitch terminal block characteristics	Maximum conductor cross section: 1.3 mm ² (16AWG), or 0.5 mm ² when using ferrules (highly recommended) Recommended stripping length: 6 mm Screw thread: M2 Maximum screws tightening torque: 0.3 Nm
Dimensions	width: 84.3 mm height: 41.1 mm depth: 14.5 mm
Weight	25 g (including terminal blocks and screws)

Dimensions

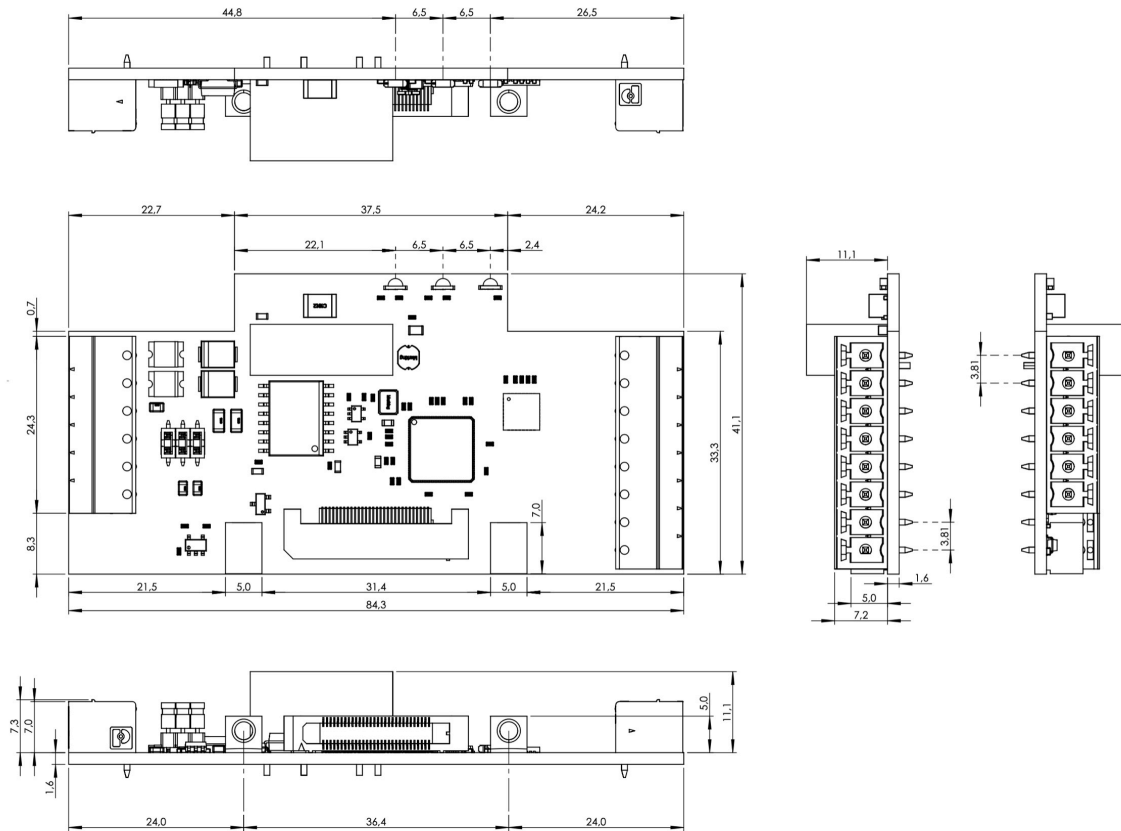

DIMENSIONS (mm)

Disposal

Waste Electrical & Electronic Equipment

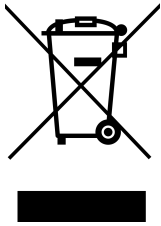

(Applicable in the European Union and other European countries with separate collection systems). This marking on the product, accessories or literature indicates that the product should not be disposed of with other household waste at the end of their working life. To prevent possible harm to the environment or human health from uncontrolled waste disposal, separate these items from other types of waste and recycle them responsibly to promote the sustainable reuse of material resources.

Household users should contact either the retailer where they purchased this product, or their local government office, for details of where and how they can take these items for environmentally safe recycling. This product and its electronic accessories should not be mixed with other commercial wastes for disposal.

Strato Pi Max contains a small non rechargeable manganese dioxide lithium coin battery.

In the Strato Pi Max, the battery is not accessible from the outside. You should first remove the case body to gain access to the Strato Pi Max circuit boards. Always remove the battery before disposing of this product.

Installation and use restrictions

Standards and regulations

The design and the setting up of electrical systems must be performed according to the relevant standards, guidelines, specifications and regulations of the relevant country. The installation, configuration and programming of the devices must be carried out by trained personnel.

The installation and wiring of connected devices must be performed according to the recommendations of the manufacturers (reported on the specific data sheet of the product) and according to the applicable standards.

All the relevant safety regulations, e.g. accident prevention regulations, law on technical work equipment, must also be observed.

Safety instructions

Carefully read the safety information section at the beginning of this document.

Set-up

For the first installation of the device proceed according to the following procedure:

- ✓ make sure all power supplies are disconnected
- ✓ install and wire the device according to the schematic diagrams on the specific product user guide
- ✓ after completing the previous steps, switch on the power supply and other related circuits.

Conformity Information

EU

This device complies with the following applicable European Community harmonised standards:

- ✓ 2014/30/EU - Electromagnetic Compatibility Directive (EMC)
- ✓ 2011/65/EU and 2015/863/EU - Restriction of the use of certain hazardous substances in electrical and electronic equipment (RoHS 3)

The following harmonised standards have been used to demonstrate conformity to these directives:

- ✓ EN61000-6-2: 2019 - EMC Immunity standard for industrial environments
- ✓ EN 61000-6-3: 2021 - EMC Emission standard for residential, commercial and light-industrial environments

The declaration of conformity is available at: <https://www.sferalabs.cc>

USA

This equipment has been tested and found to comply with the limits for a Class B digital device, pursuant to part 15 of the FCC Rules. These limits are designed to provide reasonable protection against harmful interference in a residential installation. This equipment generates, uses and can radiate radio frequency energy and, if not installed and used in accordance with the instructions, may cause harmful interference to radio communications. However, there is no guarantee that interference will not occur in a particular installation. If this equipment does cause harmful interference to radio or television reception, which can be determined by turning the equipment off and on, the user is encouraged to try to correct the interference by one or more of the following measures:

- Reorient or relocate the receiving antenna
- Increase the separation between the equipment and receiver
- Connect the equipment into an outlet on a circuit different from that to which the receiver is connected
- Consult the dealer or an experienced radio/TV technician for help.

Shielded cables must be used with this equipment to maintain compliance with FCC regulations.

This device complies with Part 15 of the FCC Rules. Operation is subject to the following two conditions: (1) this device may not cause harmful interference, and (2) this device must accept any interference received, including interference that may cause undesired operation.

CANADA

This Class B digital apparatus complies with Canadian ICES-003.

Cet appareil numérique de la classe B est conforme à la norme NMB-003 du Canada.

RCM AUSTRALIA / NEW ZEALAND

This product meets the requirements of the standard EN 61000-6-3: 2021 - Emission for residential, commercial and light-industrial environments.