

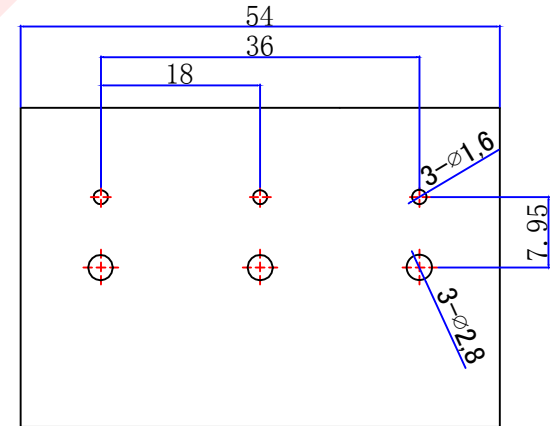

PrOduct NO.		DOSIN-801-0007		
REV	DESCRIPTION	DWN	DATE	APPROVEN
A	First issue	Mr. chen	18/06/06	John kine
B				

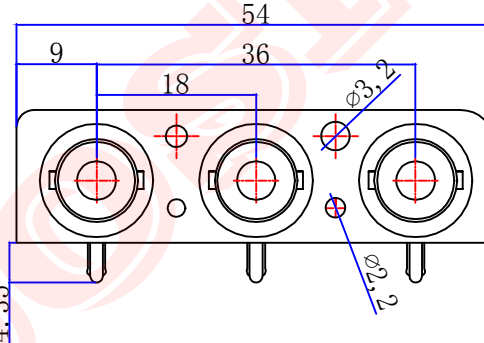
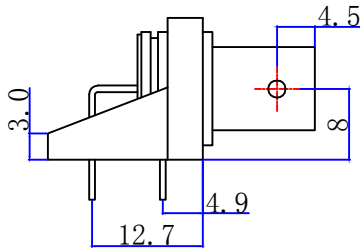
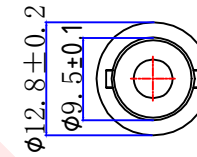
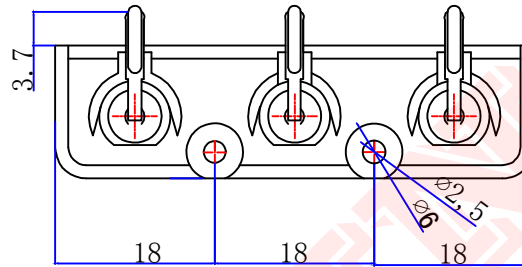
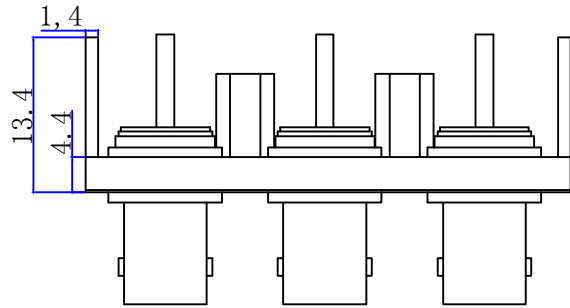

**Specification:**

Impedance: 50 Ohms  
 VSWR: 1.3MAX  
 Frequency range: DC~4G  
 Working Voltage: 500V rms @ sea level  
 Insulation resistance: 5000 Ohms min  
 Temperature range: -55°C TO +155°C  
 Relative temperature: ≤95% (40° C ±2° C)  
 Drawings products are in line with ROHS standards.

1	BODY	Zinc	NI:80-120u"	3
2	PIN	Brass	NI:80-120u"	3
3	PANEL	ABS	BLACK	1
4	IRON PLATES	IRON	NI:80-120u"	1
5	SOLDER COLUMN	IRON	NI:80-120u"	3
6				
7				
8				
9				
10				
NO	Component Number	Material	Finish	QTY

NOTE:	
DRAWN	2012/04/06
Zelin. Zhang	
CHECKED	
APPROVALS	07/04.2012
John	

Tolerance	X. ±0.15 X.X ±0.10 X.XX ±0.05 Angular ±5°
View	
UNIT	MM
SCALE	1:1

<b>Dosing Industrial(H.K)Co.Ltd</b> 东莞市德索五金电子制品有限公司 <b>Dosing Hardware Electronics Co.,Ltd</b>		E-mail: dosin2005@163.com dosin2005@dosin-china.com Web: http://www.china-guan.com TEL: (0086)769-81153906 FAX: (0086)769-81875836	
Name: BNC JACK 1x3 Port 90° PCB Mount			
SIZE	Product NO.	REV	
A	DOSIN-801-0007	A	
DateTime	CAD FILE	SHEET: 1 OF 1	
2018/06/06	D/company drawings/BD		