

Explore the next sense



Getting Started Guide A121 Lens Evaluation Kit LH112/120/132/122

December 2023

Getting Started Guide

The Lenses are delivered as kits with two different lenses, a cover and a holder. The holder comes in four versions: LH112 used for XS121, LH120 used for XE121, LH132 for XE125 and LH122 for XM126. This getting started guide will show you how to setup the lens evaluation kit.

We assume that you already have a sensor evaluation kit (EVK) XC120 + XE121 + XS121 or a module EVK XE125 or XE126 (XM126+XB122) and that you are familiar with how to use it.

Acconeer reference lenses are made of Polyamide PA12. They are solid.

Kit content

The Lens Kit from Acconeer is delivered including 4 parts.

1. Lens and PCB holder
2. HBL Lens (Hyperbolic Lens)
3. FZP Lens (Fresnel Zone Plate)
4. Flat cover

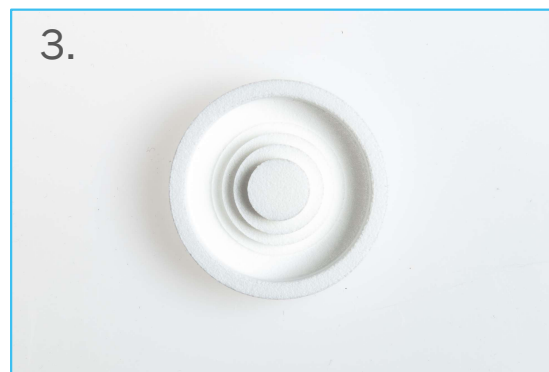
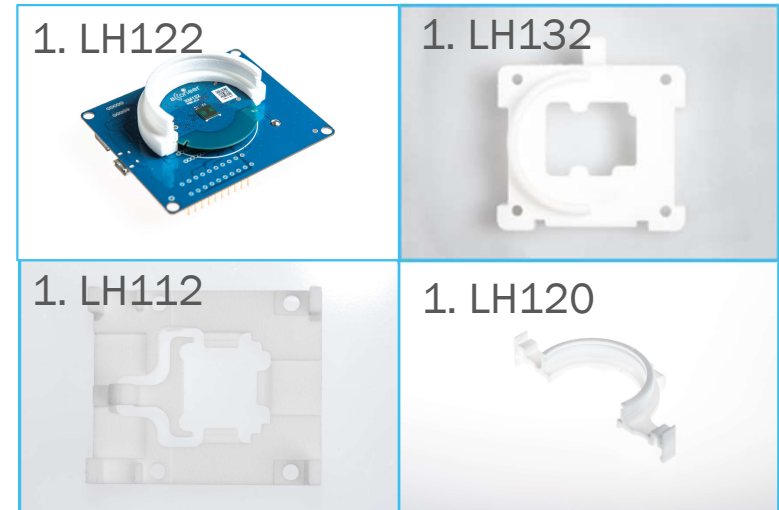

How to Assemble LH112

First thing you need to do is to fit the PCB into the holder. The exact sensor position in relation to the lens is important for optimal performance.

XS121 in the holder



How to Assemble LH120

First thing you need to do is to fit the PCB into the holder. After XE121 is securely fit you can easily connect it to your XC120 breakout board. *Be careful to not try to fit the holder to XE121 when it is connected to the XC120 PCB.* The exact sensor position in relation to the lens is important for optimal performance.

XE121 in the holder, mounted on XC120, with HBL lens in the lower picture.

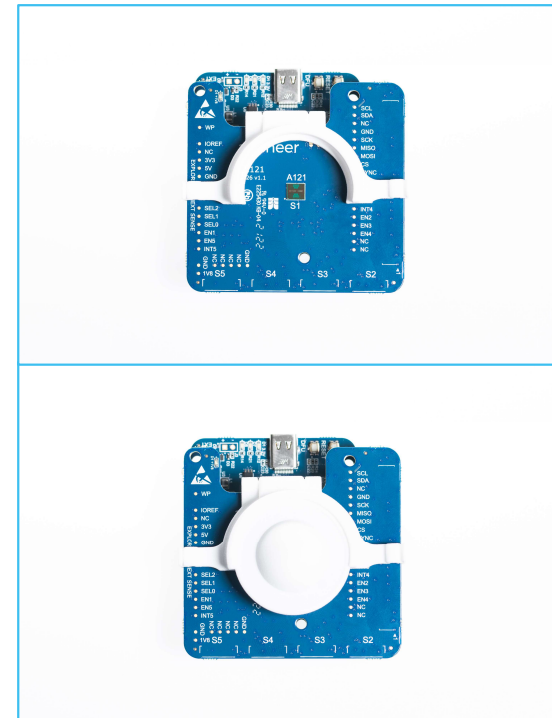

How to Assemble LH132

XE132 in the holder



First thing you need to do is to fit the PCB into the holder. (To the left.) We recommend to screw the PCB to the holder. The exact sensor position in relation to the lens will be important for optimal performance. The PCB only fits one way into the holder without obstructing the USB.

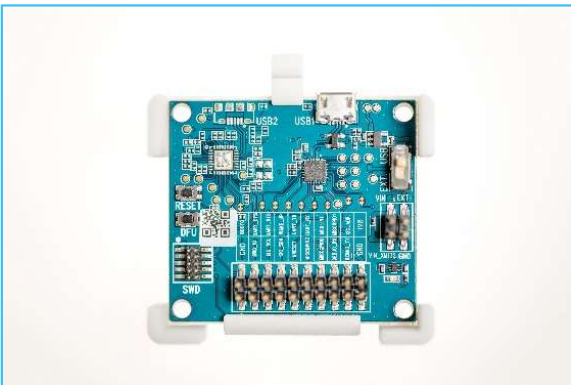

The pictures illustrates XE/XM132 in the LH132 holder, but XE/XM125 has the same form factor and is mounted the same way in the holder.

How to Assemble LH122

XM122/XM126 in the holder

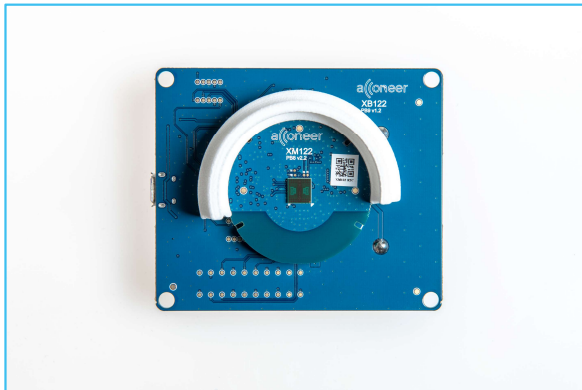

First thing you need to do is to fit the PCB into the Holder. After XM122/XM126 is securely fit you can easily connect it to your XB122 breakout board if needed. *Be careful not to fit the holder to XM122/XM126 when it is connected to the XB card. The connector is sensitive and can break.*

The exact sensor position in relation to the lens will be important for optimal performance.

To the right is an example how to NOT place the sensor. Ensure that the BT antenna always is placed in the gap of the holder to ensure best performance.

XM122/XM126 suboptimal placement



Distance from PCB to Lens for LH112 /120 /132/122

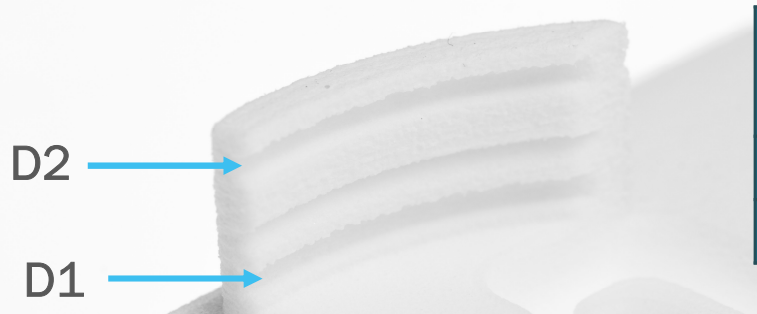

	LH112			LH120			LH132			LH122		
	XS121			XE121			XE125			XM126		
	FZP	HBL	Cover	FZP	HBL	Cover	FZP	HPL	Cover	FZP	HBL	Cover
D1[mm]	3.1	3.1	4.5	3	3	5	3	3	5	3	3	5
D2[mm]	8.2	8.3	N/A	8.2	8.2	N/A	8.2	8.2	N/A	8.2	8.2	N/A

Both lenses can be fit in the holder in two different positions: D1 or D2. The positioning numbering is identical for all lens kits.

The cover (see page 3) is only used in D1.

The two positions will give you slightly different performance.

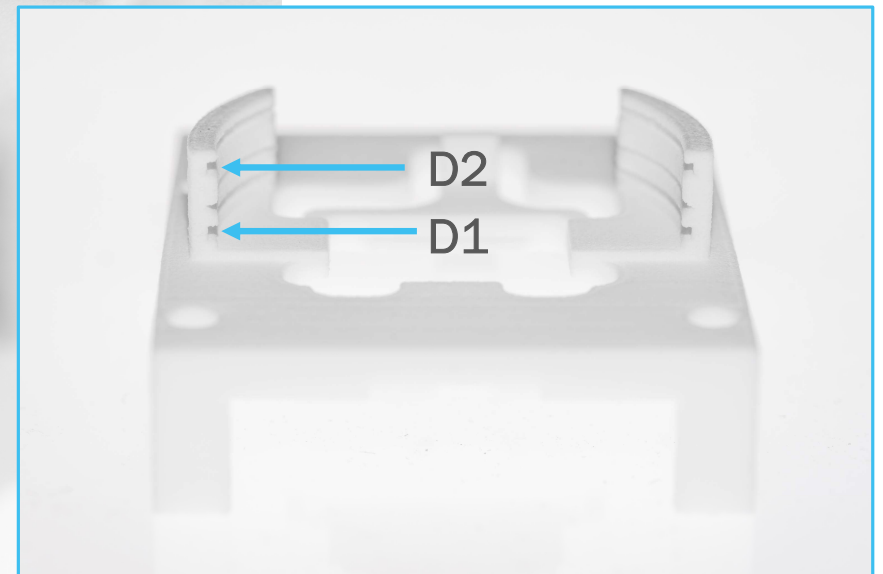

Performance Tables

On the following pages, the expected performance of the lenses, cover and holders are summarized. The performance is defined by the following parameters:

- Maximum Radar Loop Gain (Max RLG)
- Radar Loop Gain Half Power Beamwidth (RLGHPBW)

Definitions:

The Max RLG is the maximum value of the received power measured by the radar itself, meaning that it is the sum of the gain in the radar TX and RX path. The Max RLG is normalized to the Radar Loop Gain of Free Space Sensor Boresight.

The RLGHPBW includes the attenuation in both the TX and RX radar path and is defined as the angular separation between the two points at which the gain has decreased by 3dB relative to the maximum main lobe value, when the radar itself is used to measure the reflected power. The Radar Loop Gain Radiation Pattern is normalized to Free Space Sensor Boresight. For details regarding the measurement setup, refer to HW and Physical integration guideline, chapter 1.2.

Performance Tables

Below is an example of the measured parameters (XE121 Radar Loop Gain Radiation Pattern in H-plane with LH120 and Hyperbolic lens placed at distance D1):

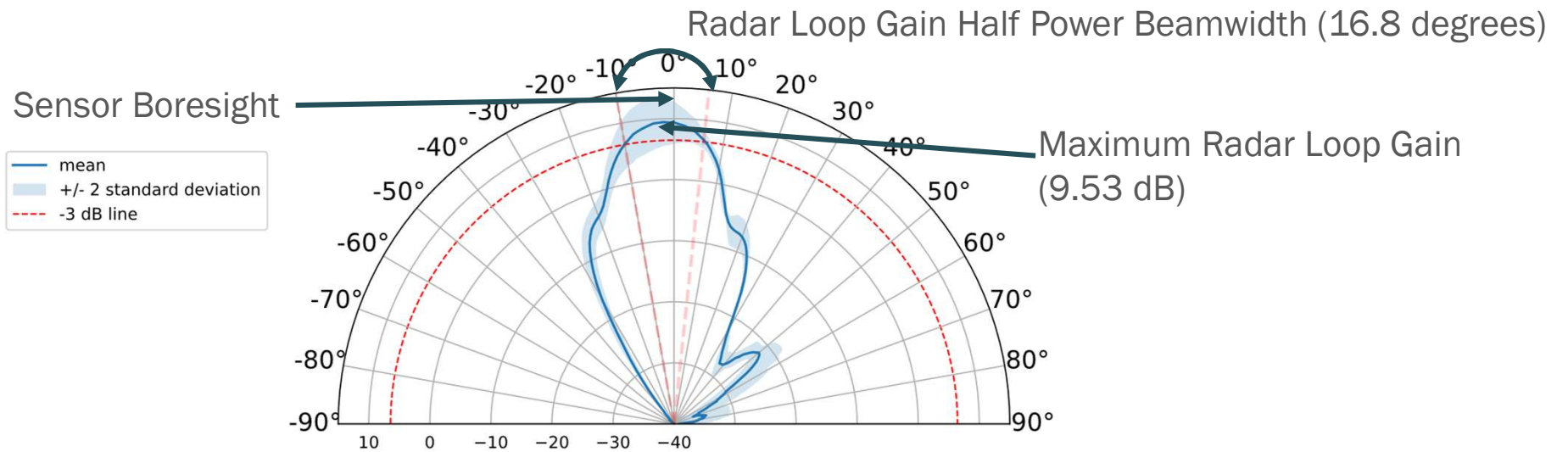

Performance Table LH112 + XS121

Acconeer has verified both lenses on both EVK variants. The expected performance can be viewed in the table to the right.

XS121 with LH112 holder	Max RLG (dB)		RLGHPBW-E (degree)		RLGHPBW-H (degree)	
	D1	D2	D1	D2	D1	D2
HBL	10.93+/-1.66	18.11+/-1.77	13.8+/-1.5	8.8+/-0.8	11.20+/-0.8	8.8+/-1.5
FZP	10.97+/-1.7	16.81+/-1.32	11.80+/-1.5	8.20+/-0.80	11.0+/-1.26	7.60+/-0.98

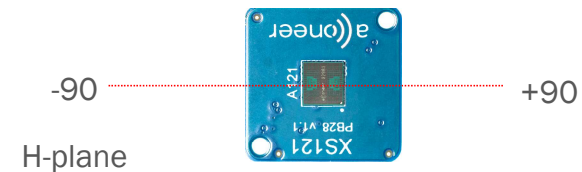
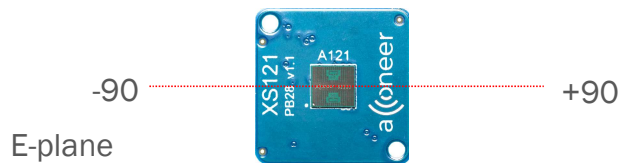

Max RLG is relative to the free-space boresight scenario.
 RLGHPBW= mean +/- 2 standard deviation over measured devices
 RLGHPBW measurement setup tolerance= +/- 2 degrees

XS121 – Free space

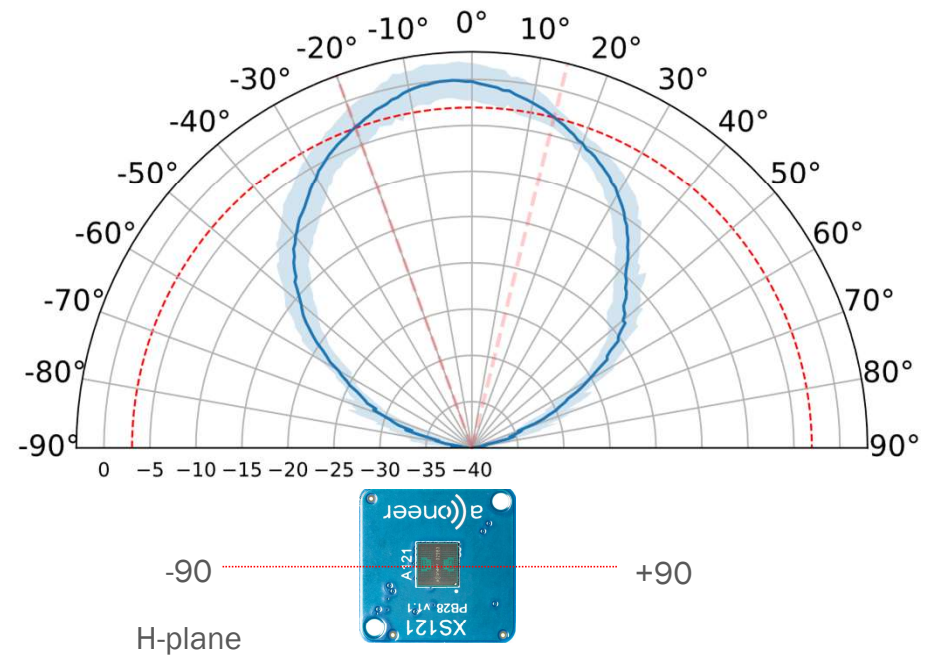
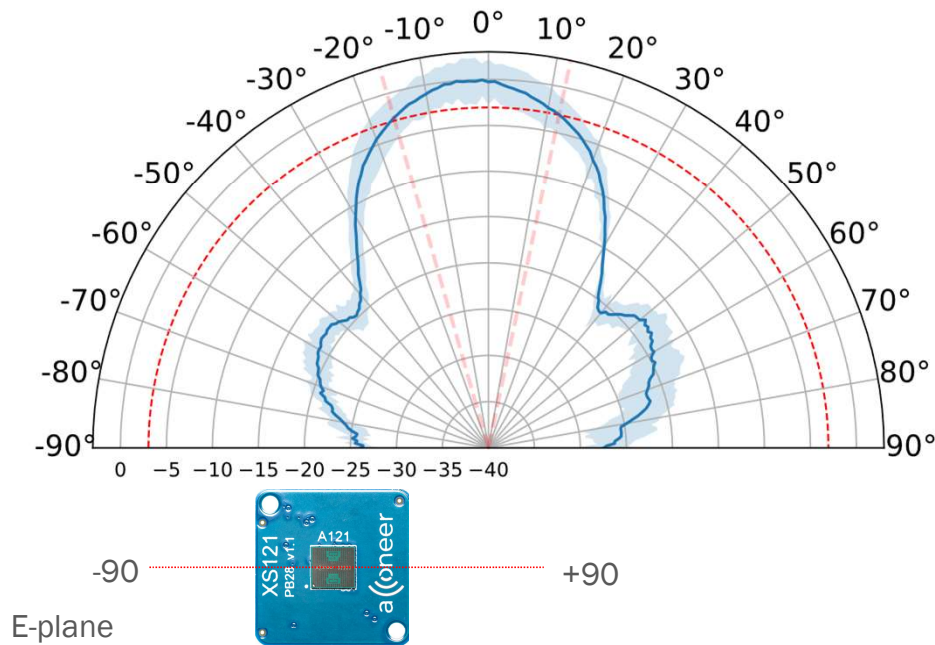

Max RLG is relative to the free-space boresight scenario.
 RLGHPBW= mean +/- 2 standard deviation over measured devices
 RLGHPBW measurement setup tolerance= +/- 2 degrees

LH112 + XS121 – Hyperbolic lens, D1

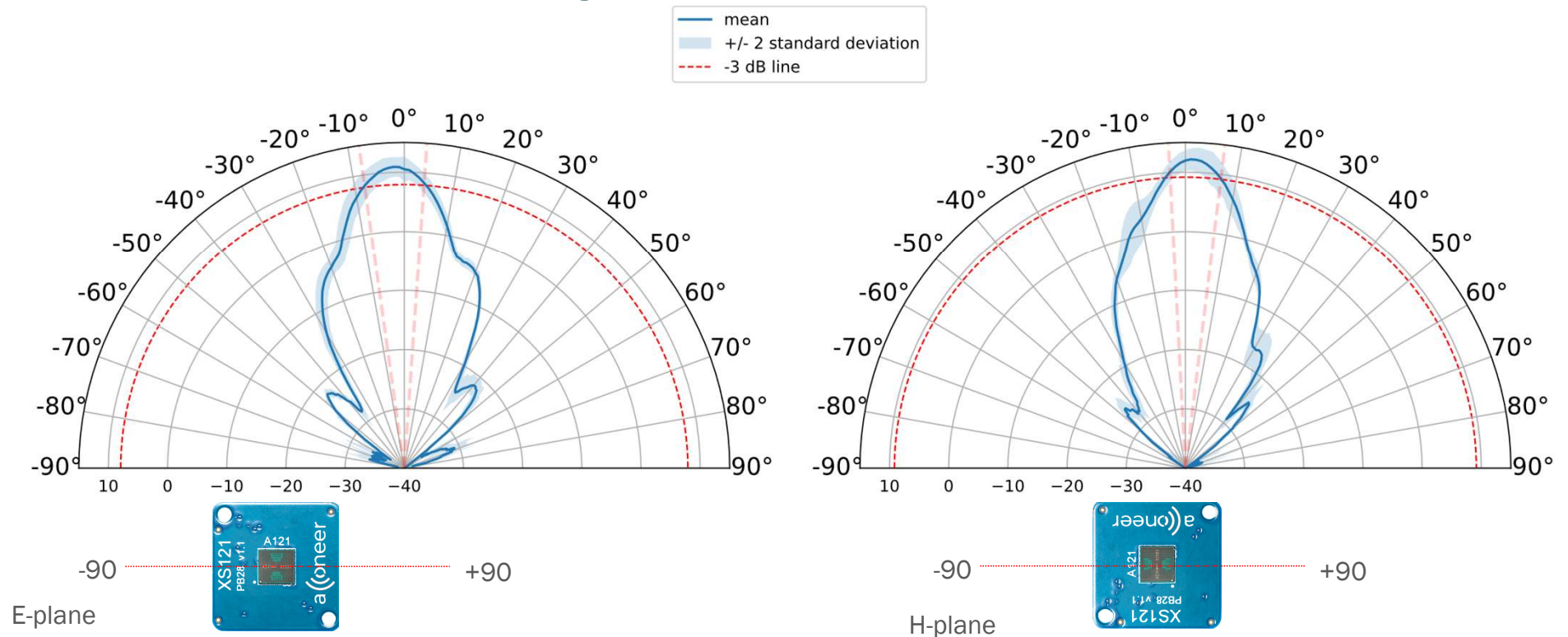

Max RLG is relative to the free-space boresight scenario.
 RLGHPBW= mean +/- 2 standard deviation over measured devices
 RLGHPBW measurement setup tolerance= +/- 2 degrees

LH112 + XS121 – Hyperbolic lens, D2

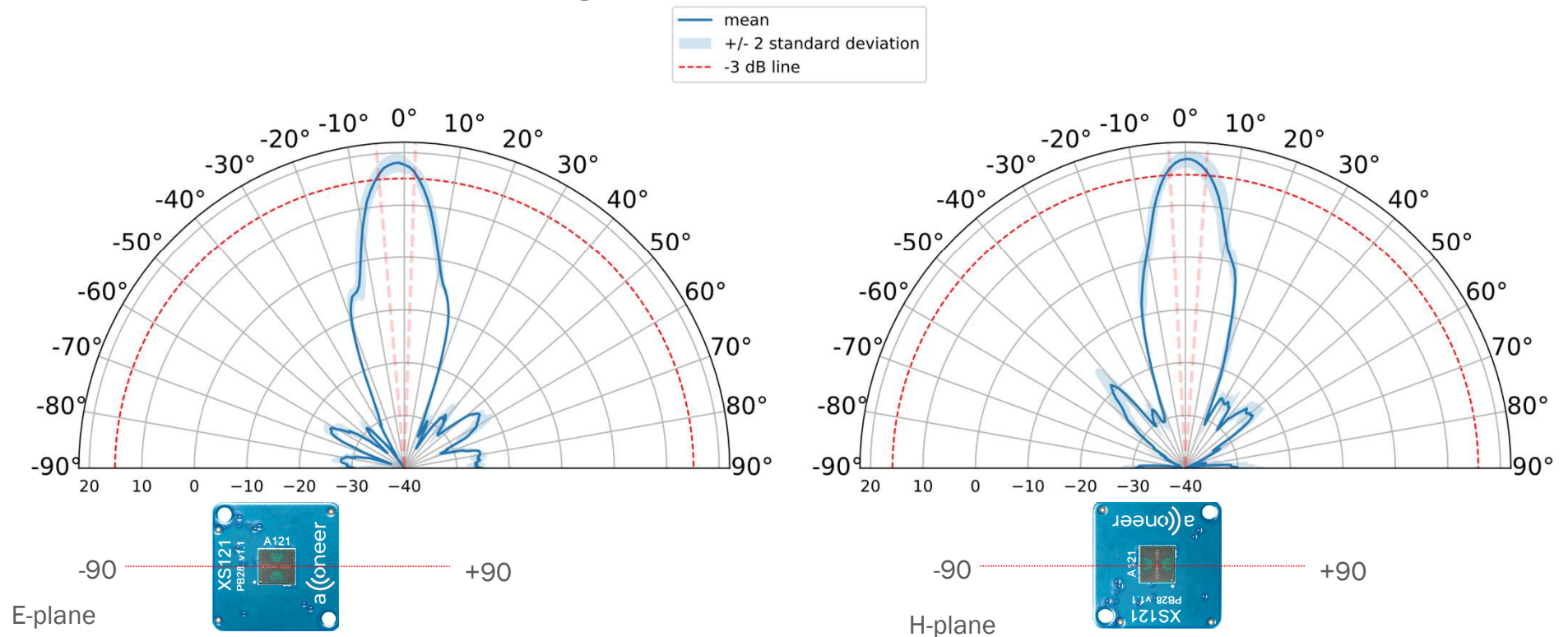

Max RLG is relative to the free-space boresight scenario.
 RLGHPBW= mean +/- 2 standard deviation over measured devices
 RLGHPBW measurement setup tolerance= +/- 2 degrees

LH112 + XS121 – FZP lens, D1

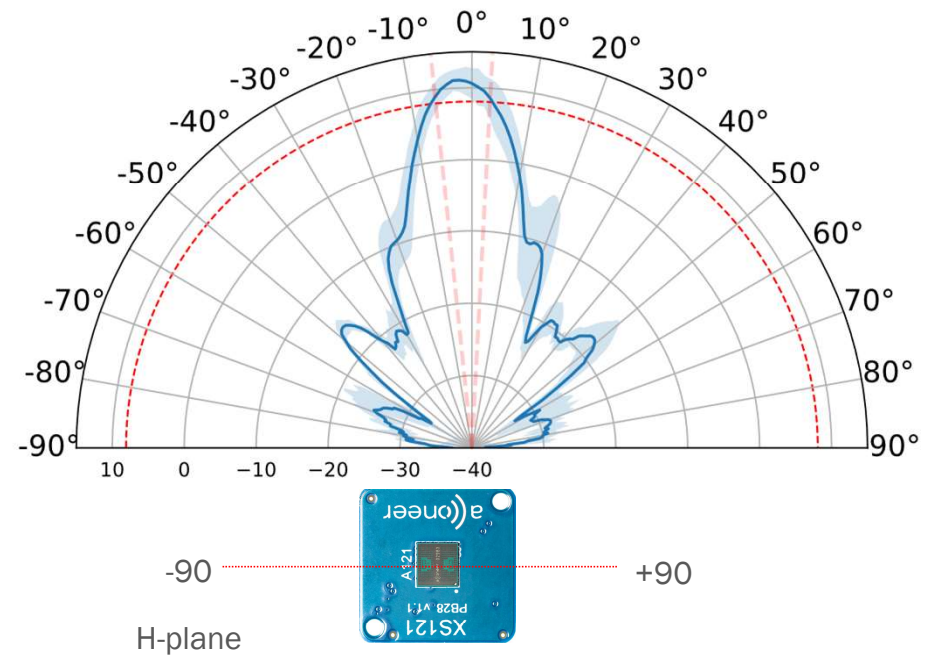
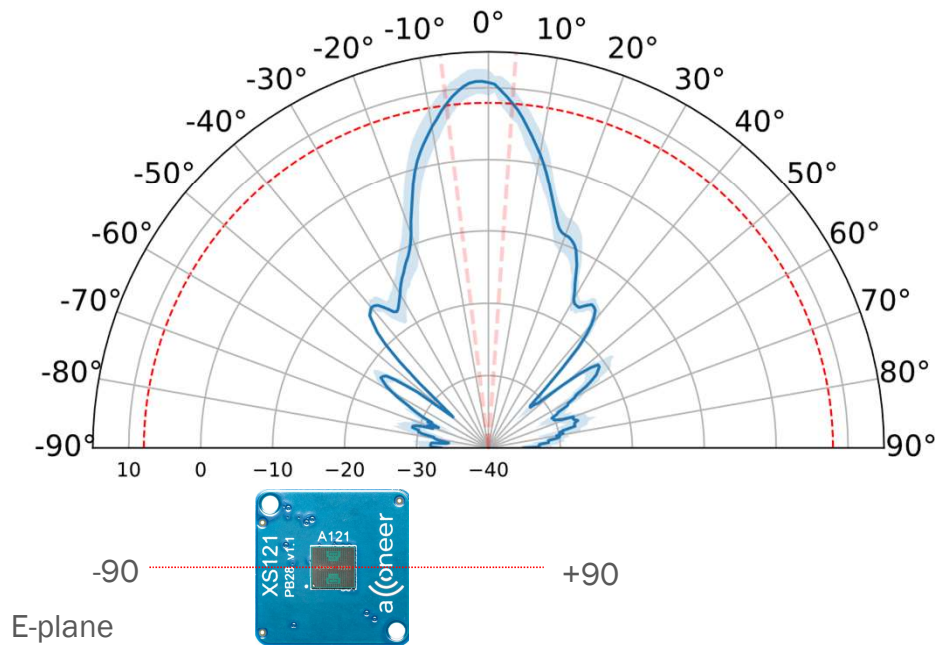
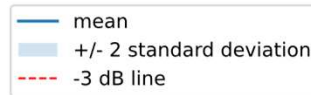

Max RLG is relative to the free-space boresight scenario.
 RLGHPBW= mean +/- 2 standard deviation over measured devices
 RLGHPBW measurement setup tolerance= +/- 2 degrees

LH112 + XS121 – FZP lens, D2

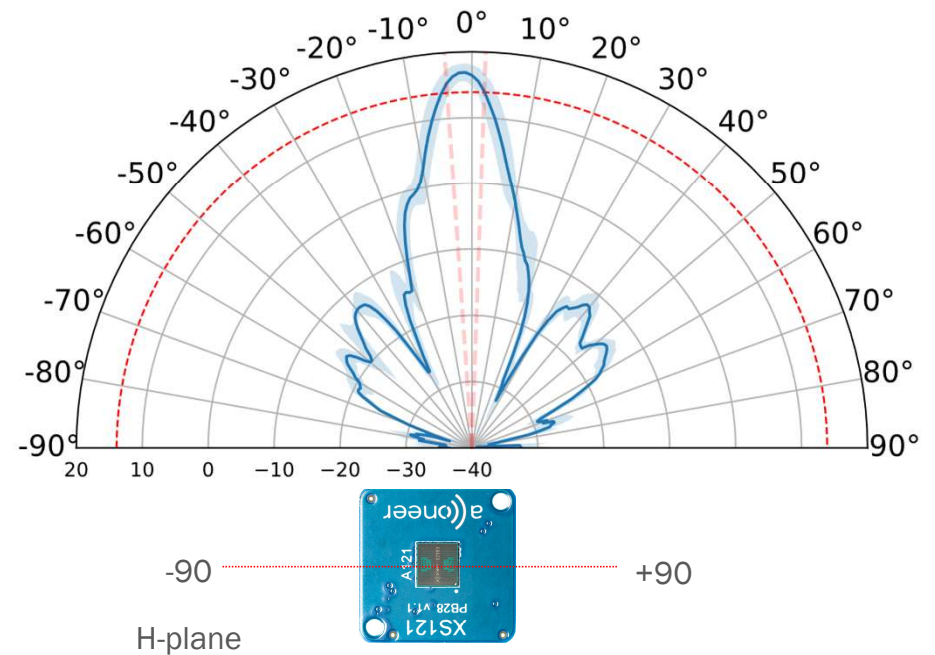
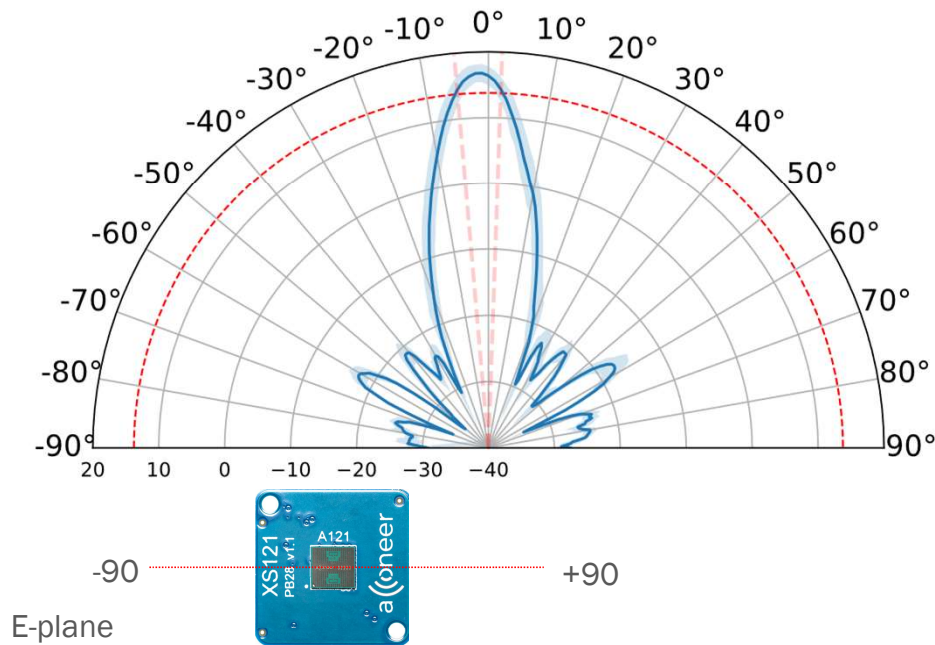
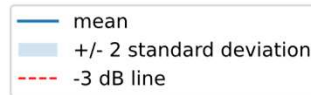

Max RLG is relative to the free-space boresight scenario.
 RLGHPBW= mean +/- 2 standard deviation over measured devices
 RLGHPBW measurement setup tolerance= +/- 2 degrees

Performance Table LH120 + XE121

Acconeer has verified both lenses. The expected performance can be viewed in the table to the right.

XE121 with LH120 holder	Max RLG (dB)		RLGHPBW-E (degree)		RLGHPBW-H (degree)	
	D1	D2	D1	D2	D1	D2
HBL	9.42+/-4.38	17.96+/-2.23	18.20+/-4.27	8.60+/-0.98	16.80+/-2.94	9.4+/-1.6
FZP	9.29+/-2.25	15.04+/-2.83	12.4+/-0.98	8.20+/-1.5	14.0+/-1.26	9.60+/-3.71

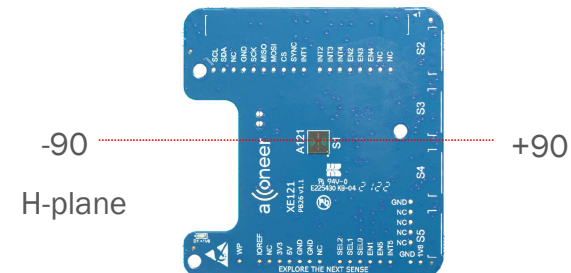
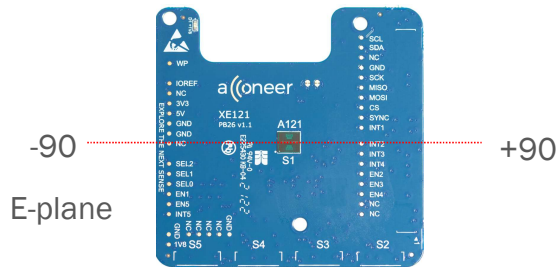

Maximum RLG is relative to the free-space boresight scenario.
 RLGHPBW= mean +/- 2 standard deviation over measured devices
 RLGHPBW measurement setup tolerance= +/- 2 degrees

XE121 – Free space

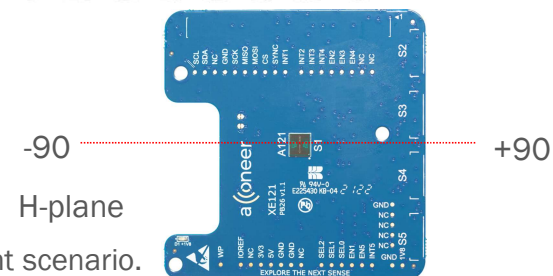
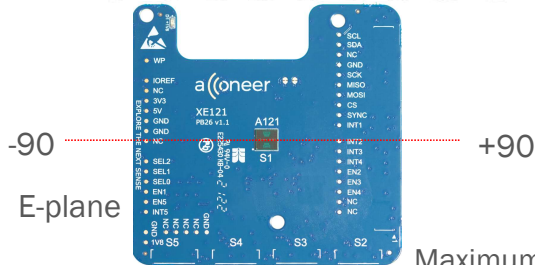
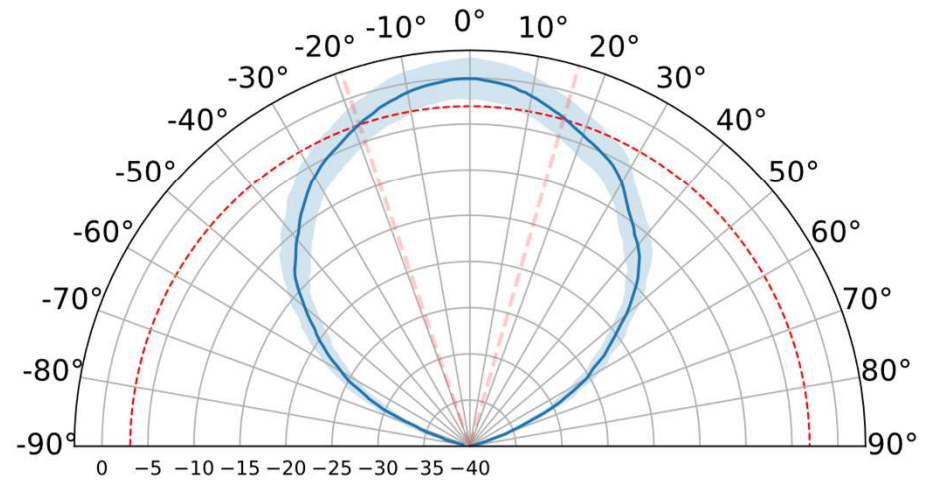
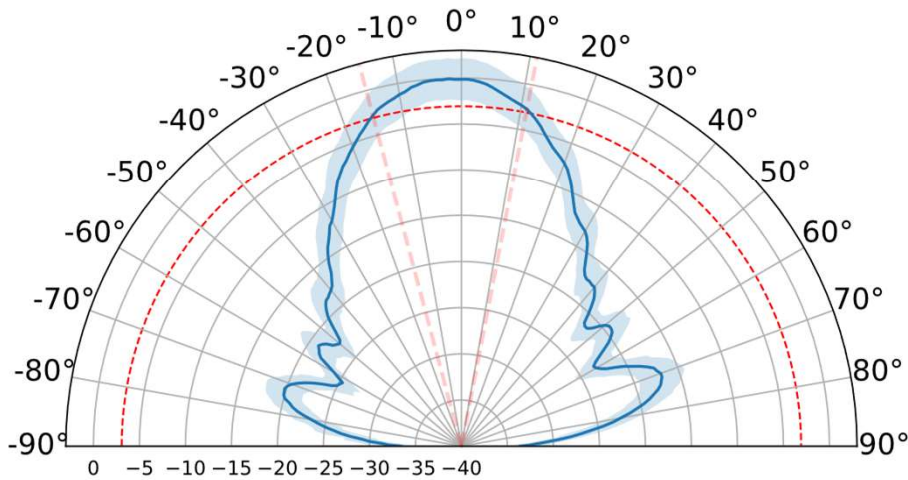

Maximum RLG is relative to the free-space boresight scenario.
 RLGHPBW= mean +/- 2 standard deviation over measured devices
 RLGHPBW measurement setup tolerance= +/- 2 degrees

LH120 + XE121 – Hyperbolic lens, D1

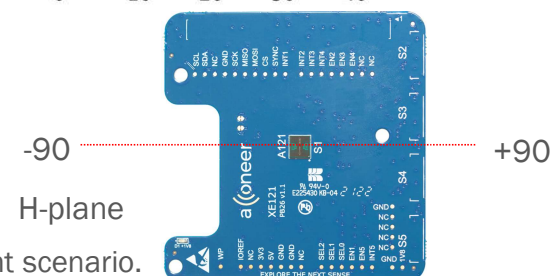
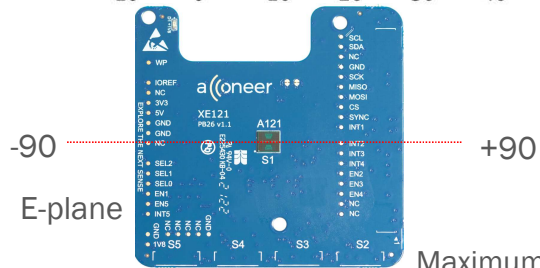
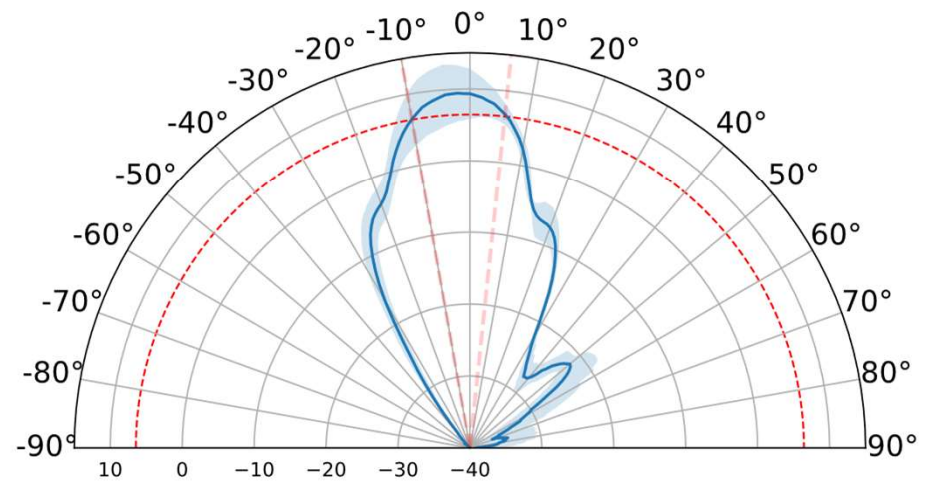
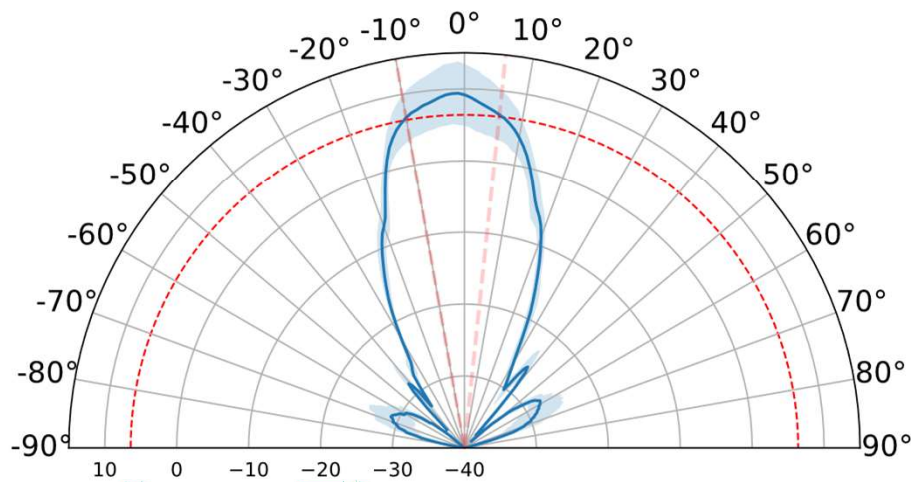
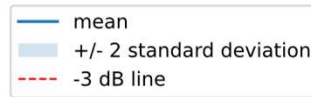

Maximum RLG is relative to the free-space boresight scenario.
 RLGHPBW= mean +/- 2 standard deviation over measured devices
 RLGHPBW measurement setup tolerance= +/- 2 degrees

LH120 + XE121 – Hyperbolic lens, D2

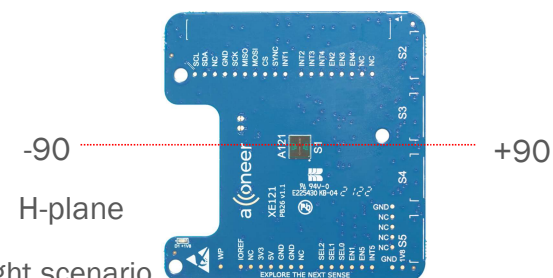
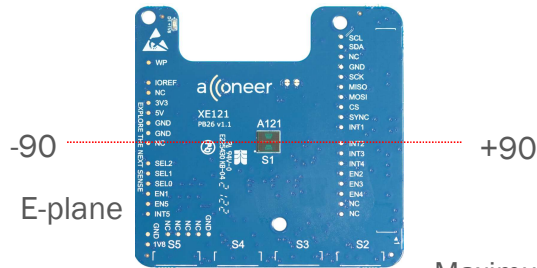
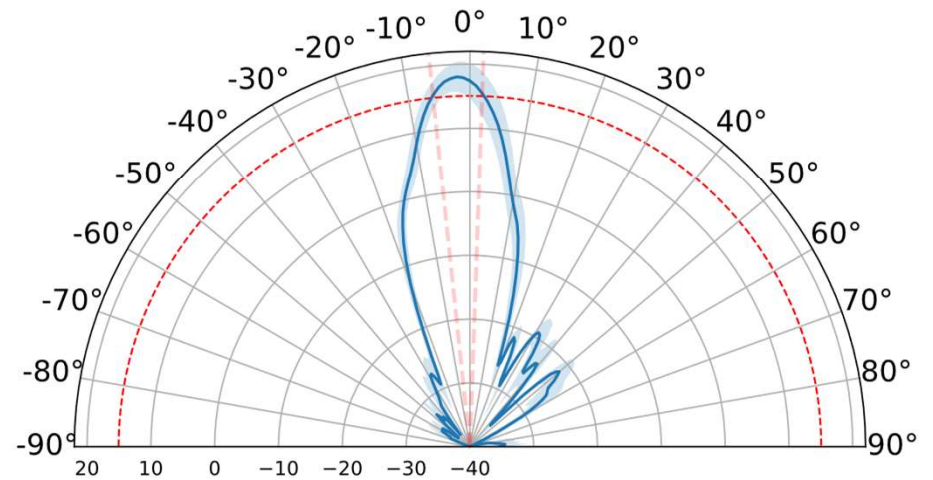
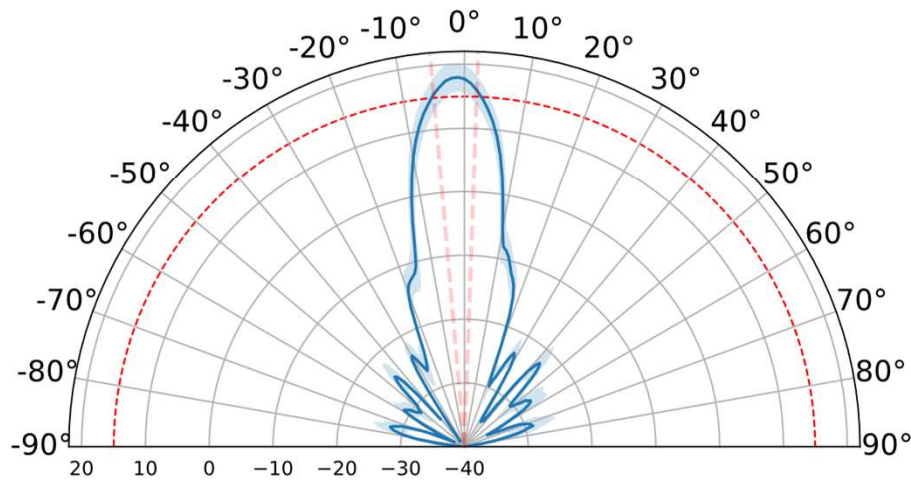
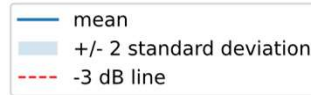

Maximum RLG is relative to the free-space boresight scenario.
 RLGHPBW= mean +/- 2 standard deviation over measured devices
 RLGHPBW measurement setup tolerance= +/- 2 degrees

LH120 + XE121- FZP lens, D1

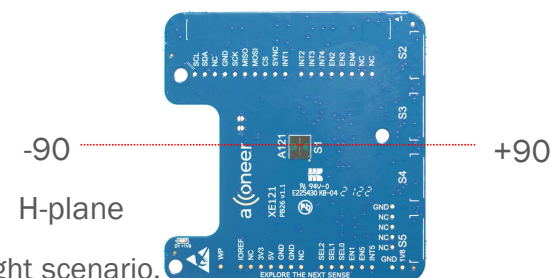
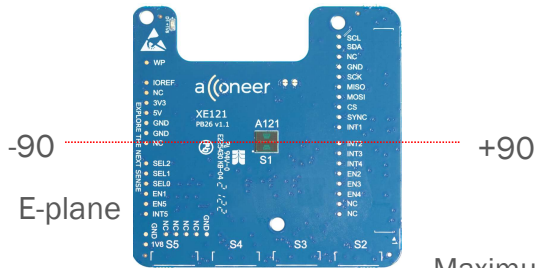
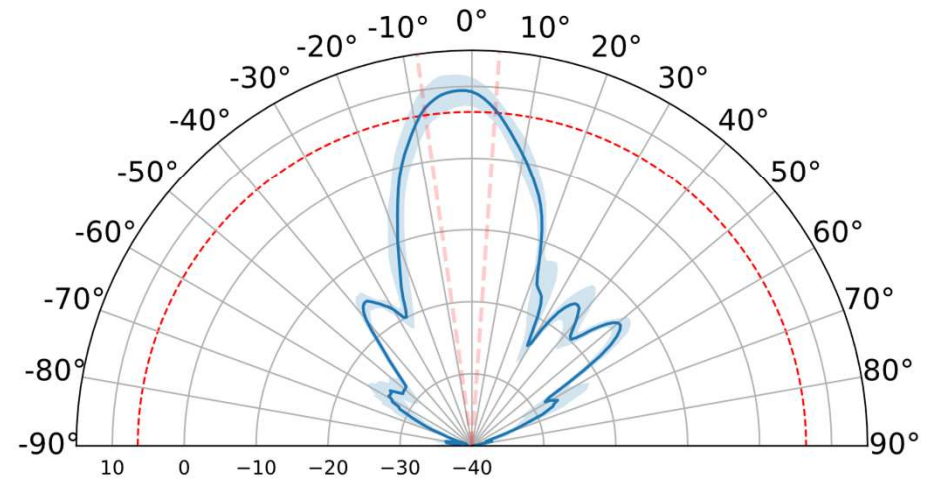
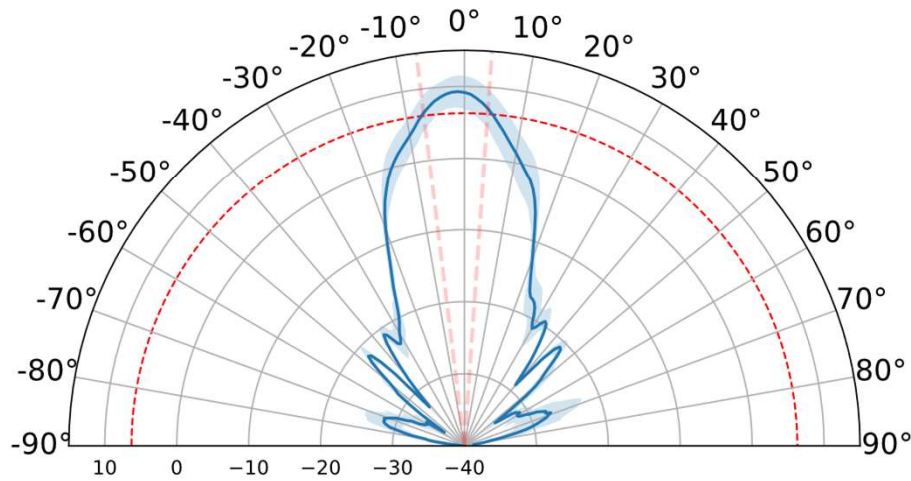
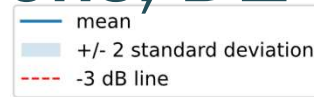

Maximum RLG is relative to the free-space boresight scenario.
 RLGHPBW= mean +/- 2 standard deviation over measured devices
 RLGHPBW measurement setup tolerance= +/- 2 degrees

LH120 + XE121 - FZP lens, D2

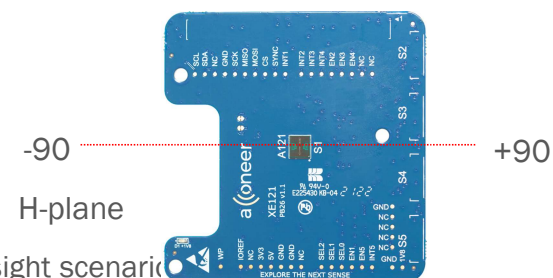
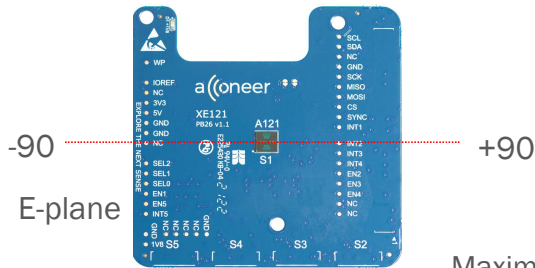
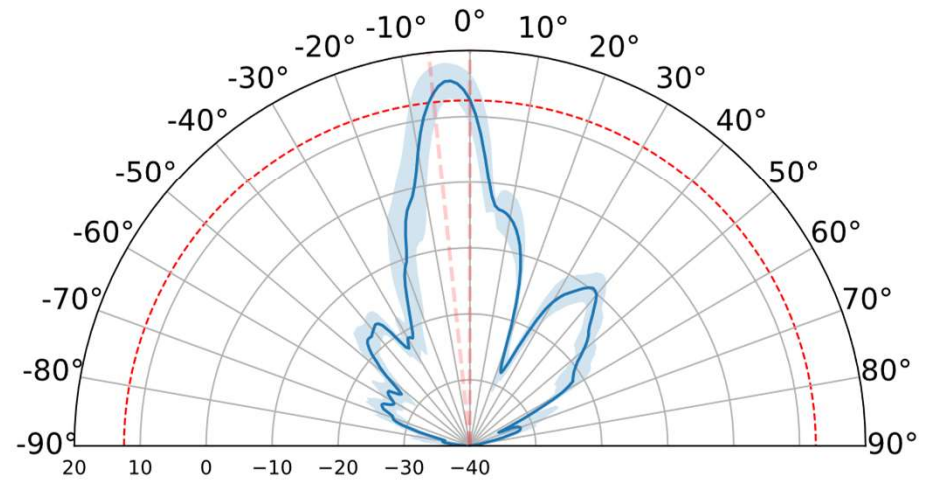
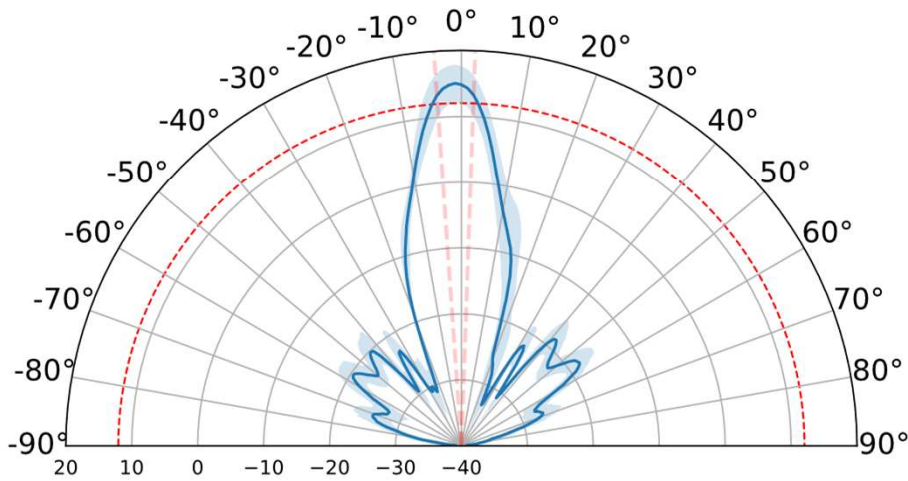
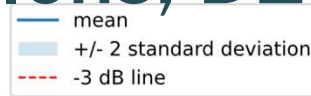

Maximum RLG is relative to the free-space boresight scenario
 RLGHPBW= mean +/- 2 standard deviation over measured devices
 RLGHPBW measurement setup tolerance= +/- 2 degrees

Performance Table LH132 + XE125

Acconeer has verified both lenses. The expected performance can be viewed in the table to the right.

XE125 with LH132 holder	Max RLG (dB)		RLGHPBW-E (degree)		RLGHPBW-H (degree)	
	D1	D2	D1	D2	D1	D2
HBL	10.56+/-1.67	17.37+/-1.14	14.0+/-1.26	9.0+/-0.2	12.80+/-1.5	8.8+/-0.8
FZP	9.16+/-1.89	14.51+/-1.84	14.2+/-1.96	7.80+/-0.8	12.60+/-2.04	7.80+/-0.8

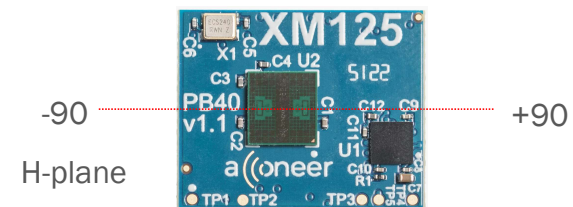
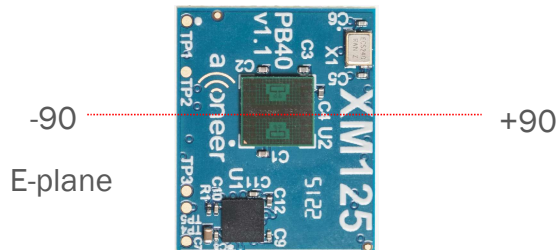

Maximum RLG is relative to the free-space boresight scenario.
 RLGHPBW= mean +/- 2 standard deviation over measured devices
 RLGHPBW measurement setup tolerance= +/- 2 degrees

XE125 – Free space

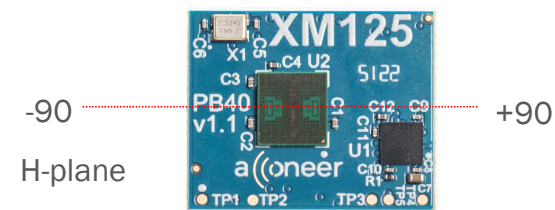
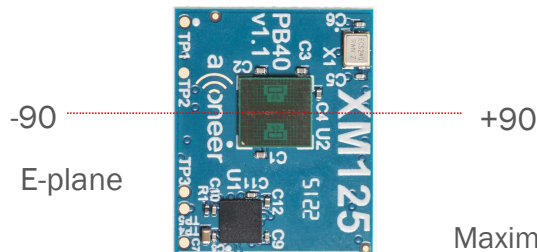
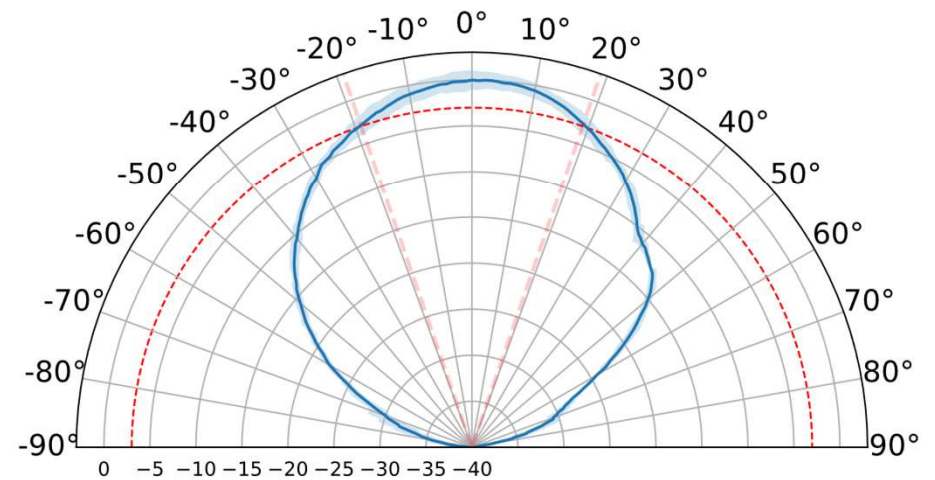
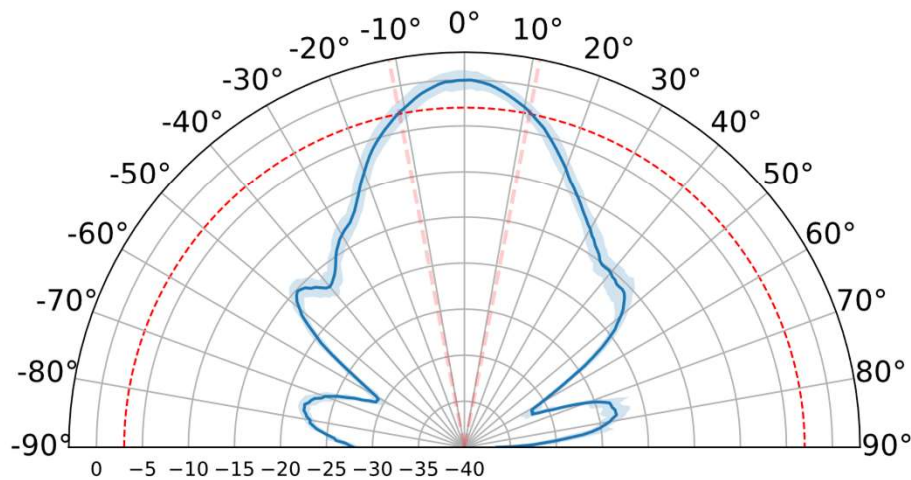
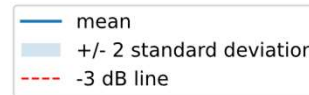

Maximum RLG is relative to the free-space boresight scenario.
 RLGHPBW= mean +/- 2 standard deviation over measured devices
 RLGHPBW measurement setup tolerance= +/- 2 degrees

LH132 + XE125 – Hyperbolic lens, D1

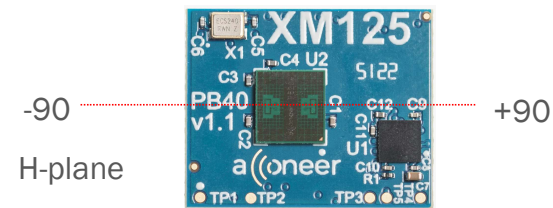
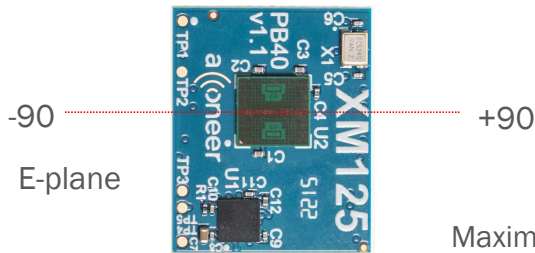
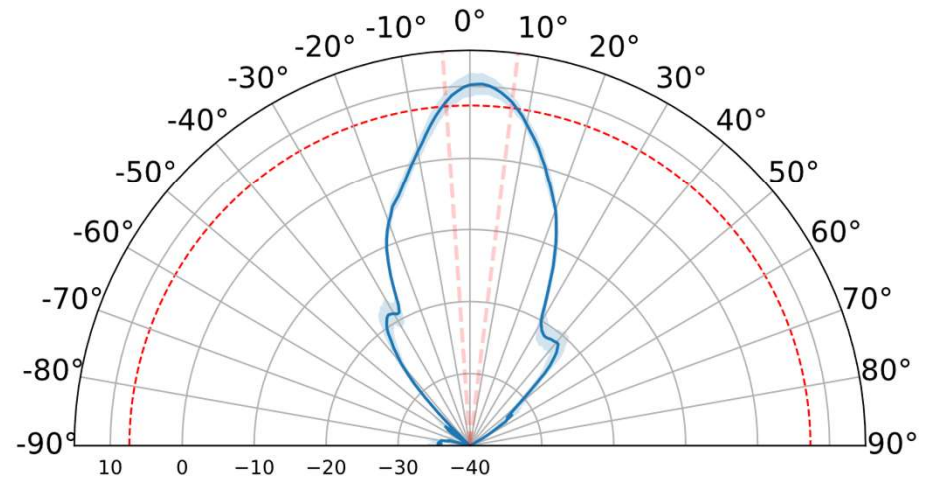
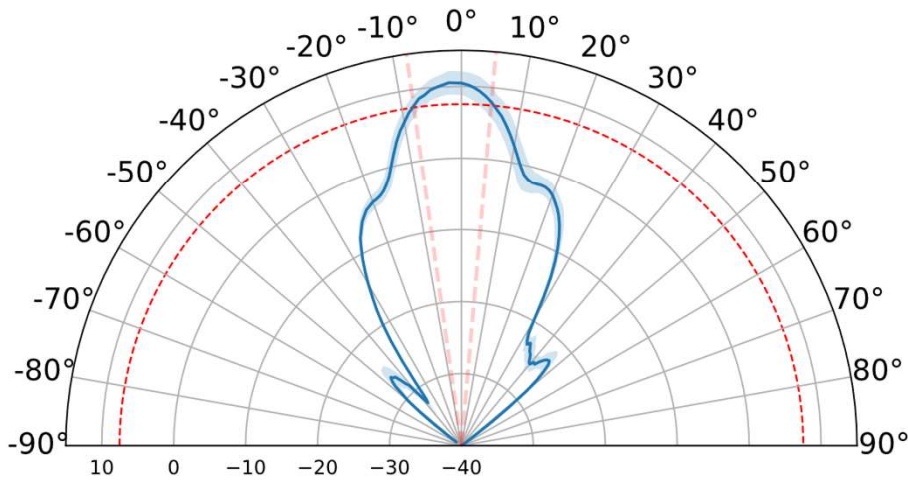
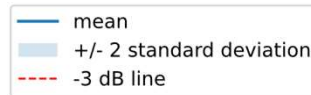

Maximum RLG is relative to the free-space boresight scenario.
 RLGHPBW= mean +/- 2 standard deviation over measured devices
 RLGHPBW measurement setup tolerance= +/- 2 degrees

LH132 + XE125 – Hyperbolic lens, D2

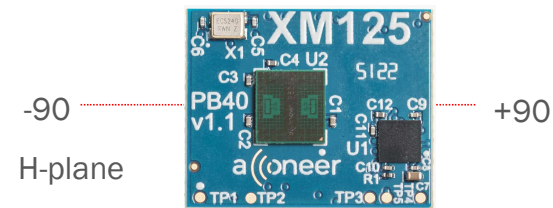
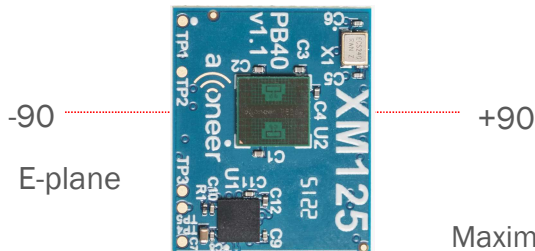
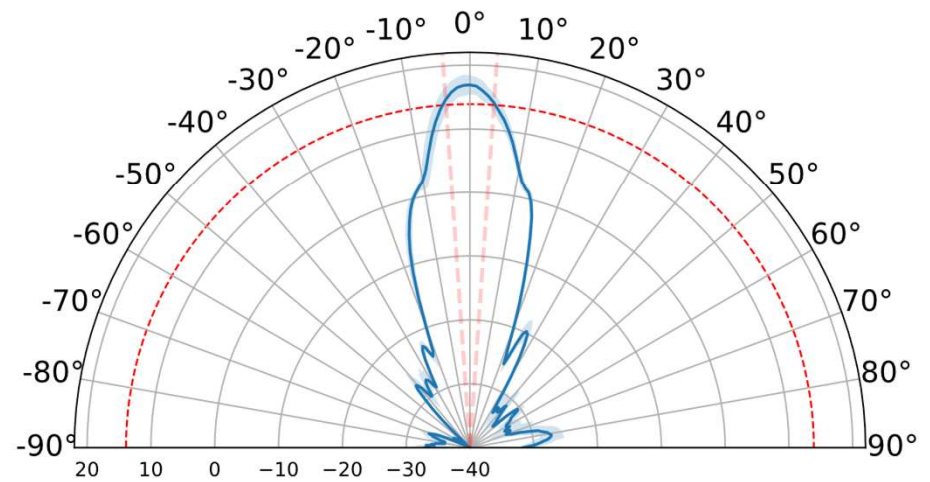
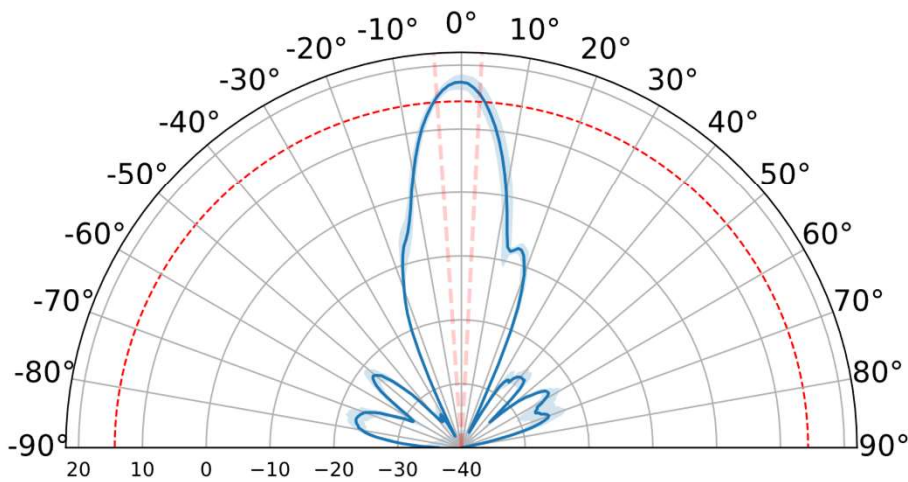
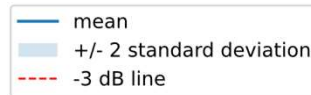

Maximum RLG is relative to the free-space boresight scenario.
 RLGHPBW= mean +/- 2 standard deviation over measured devices
 RLGHPBW measurement setup tolerance= +/- 2 degrees

LH132 + XE125 - FZP lens, D1

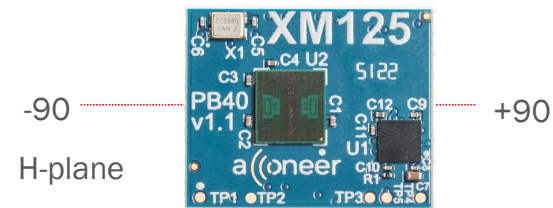
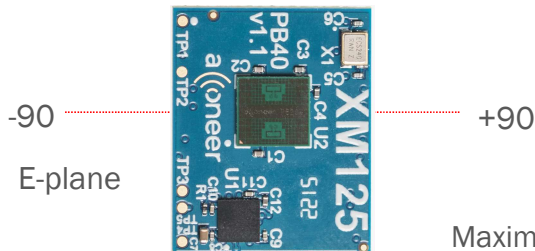
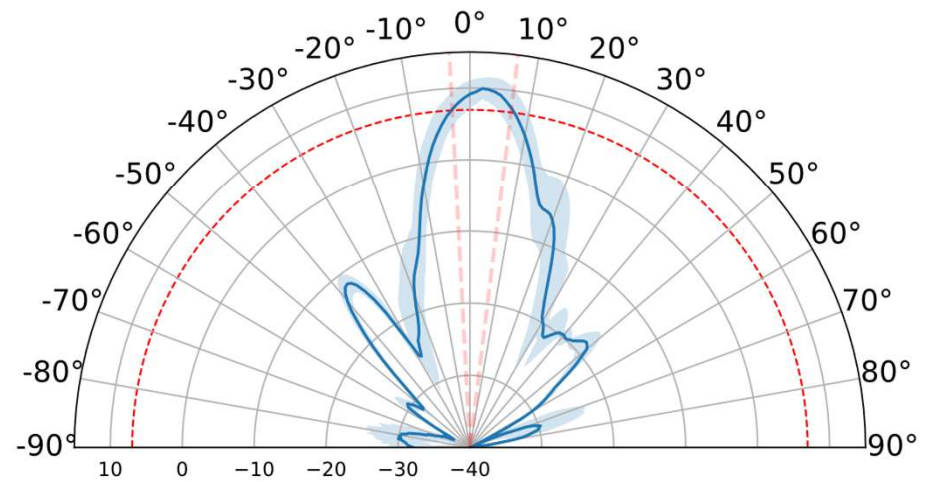
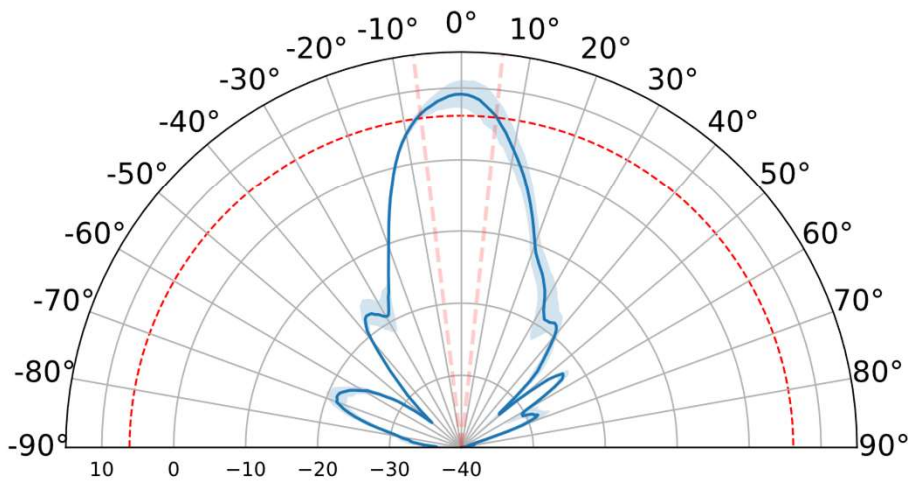
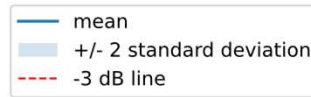

Maximum RLG is relative to the free-space boresight scenario.
 RLGHPBW= mean +/- 2 standard deviation over measured devices
 RLGHPBW measurement setup tolerance= +/- 2 degrees

LH132 + XE125 – FZP lens, D2

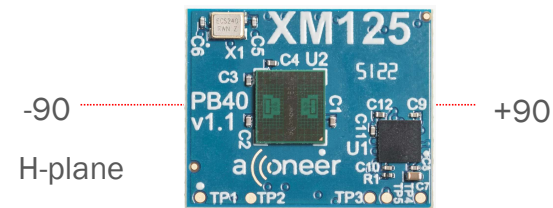
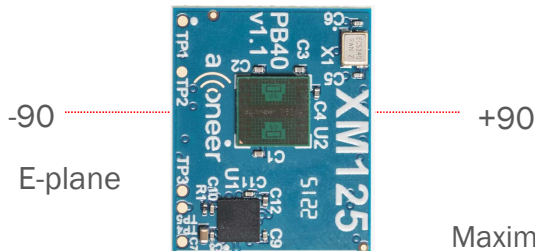
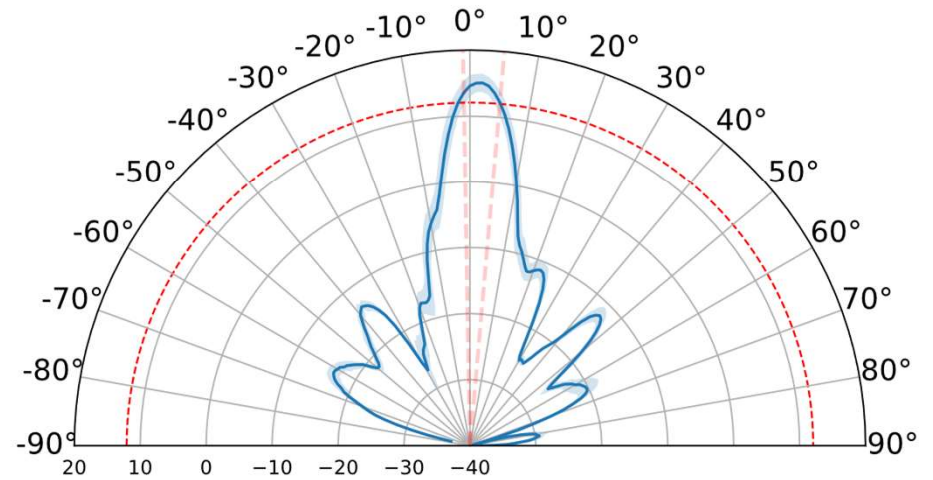
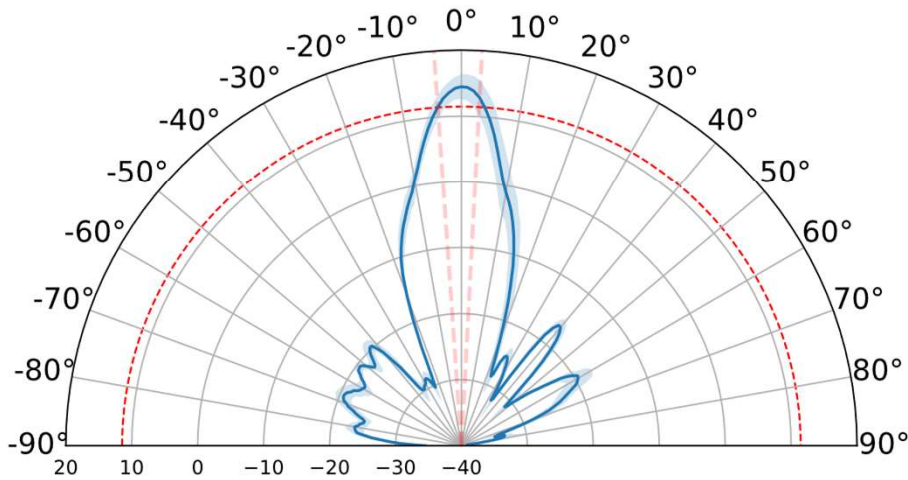
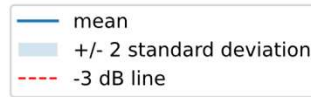

Maximum RLG is relative to the free-space boresight scenario.
 RLGHPBW= mean +/- 2 standard deviation over measured devices
 RLGHPBW measurement setup tolerance= +/- 2 degrees

Performance Table LH122 + XM126

Acconeer has verified both lenses. The expected performance can be viewed in the table to the right.

XM126 with LH122 holder	Max RLG (dB)		RLGHPBW-E (degree)		RLGHPBW-H (degree)	
	D1	D2	D1	D2	D1	D2
HBL	11.50+/-1.76	19.01+/-1.77	14.00+/-2.45	9.60+/-0.75	16.30+/-0.80	8.90+/-0.40
FZP	12.33+/-2.04	15.87+/-1.68	12.10+/-0.98	8.60+/-1.47	10.70+/-0.49	7.40+/-0.40

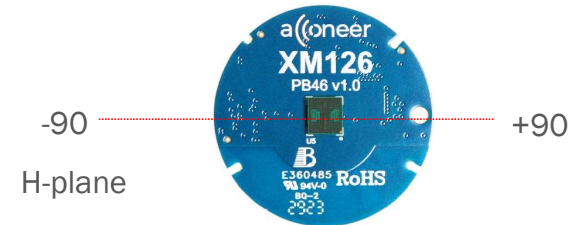
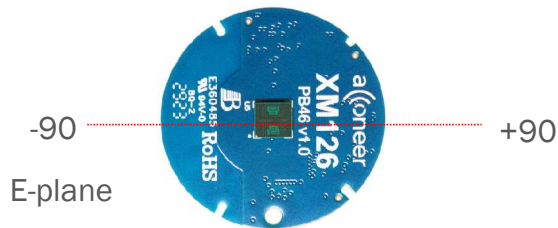

Maximum RLG is relative to the free-space boresight scenario.
 RLGHPBW= mean +/- 2 standard deviation over measured devices
 RLGHPBW measurement setup tolerance= +/- 2 degrees

XM126 - Free space

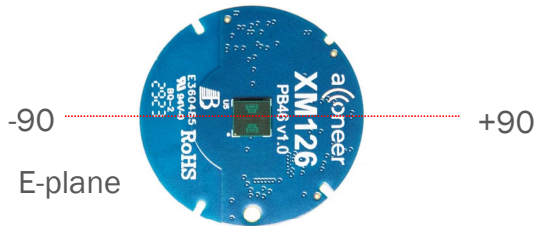
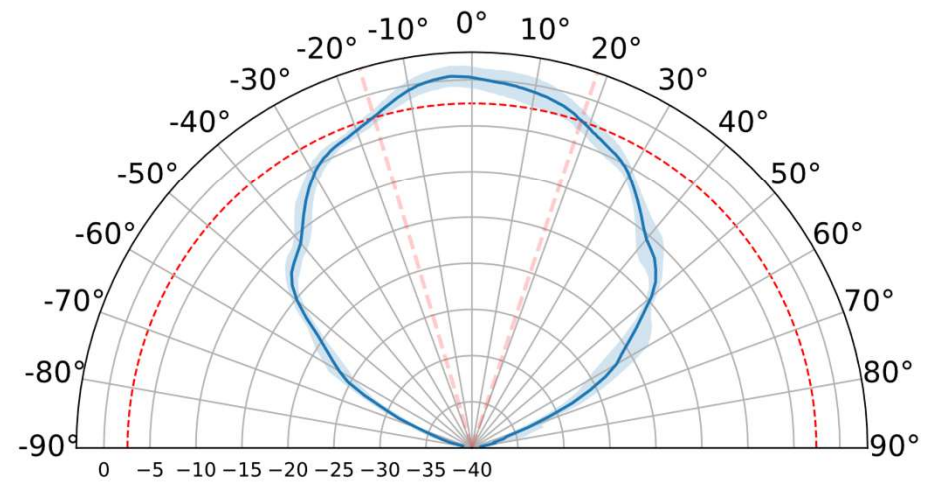
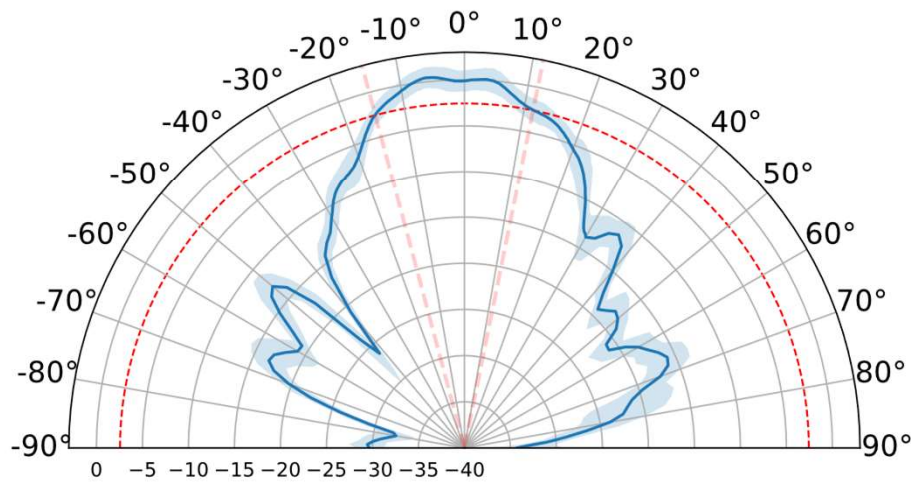
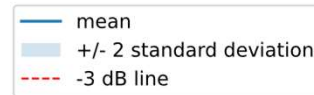

Maximum RLG is relative to the free-space boresight scenario.
 RLGHPBW= mean +/- 2 standard deviation over measured devices
 RLGHPBW measurement setup tolerance= +/- 2 degrees

LH122 + XM126 – Hyperbolic lens, D1

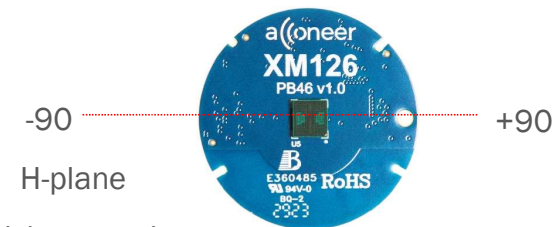
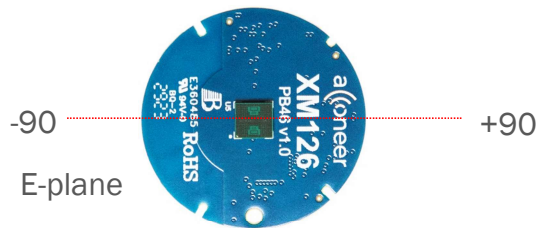
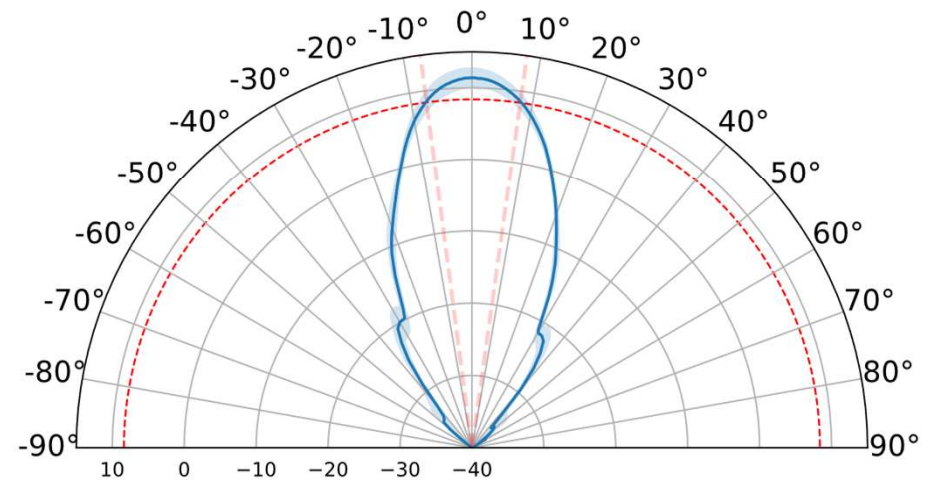
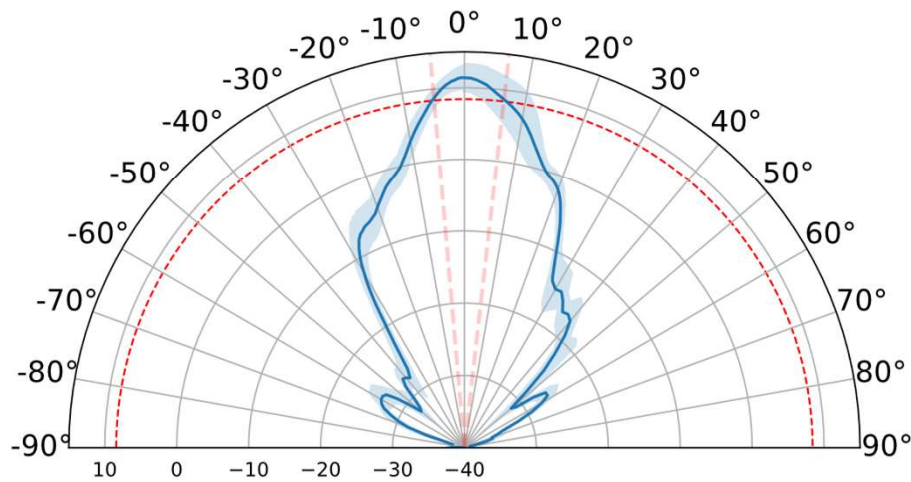
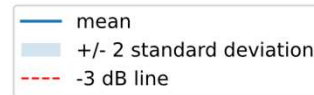

Maximum RLG is relative to the free-space boresight scenario.
 RLGHPBW= mean +/- 2 standard deviation over measured devices
 RLGHPBW measurement setup tolerance= +/- 2 degrees

LH122 + XM126 – Hyperbolic lens, D2

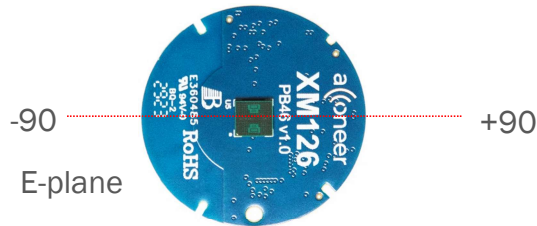
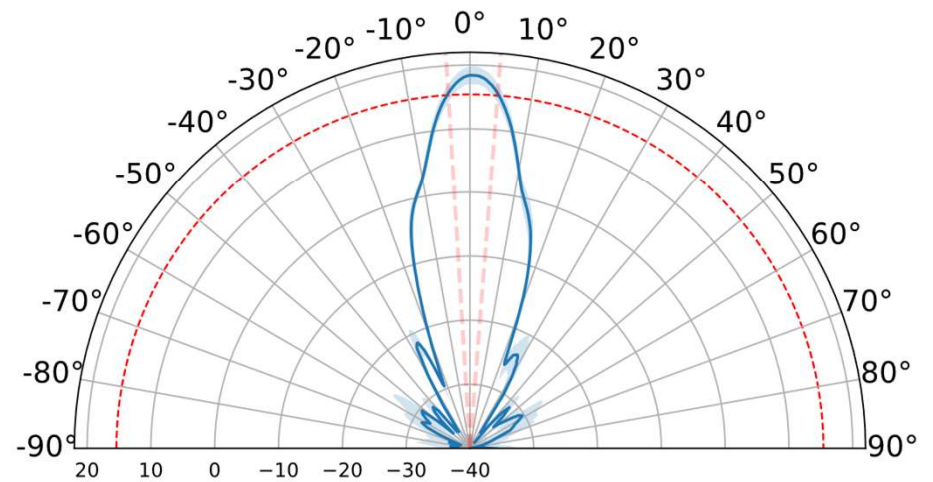
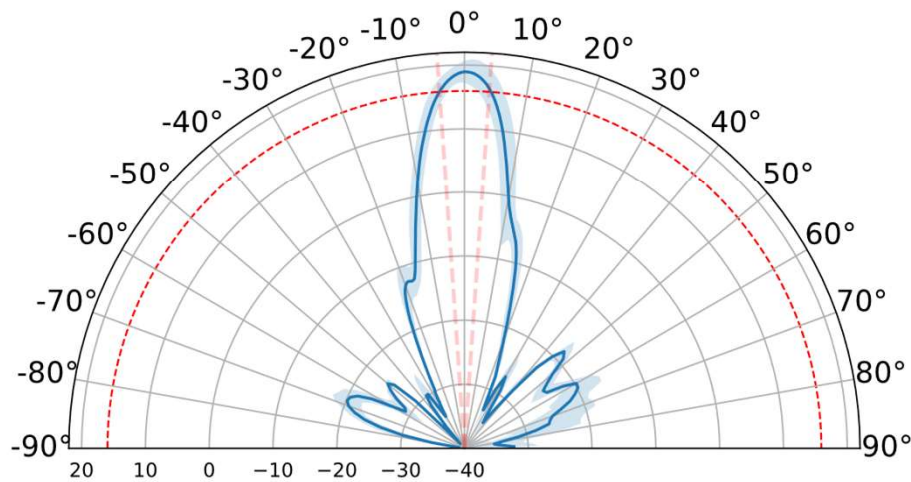
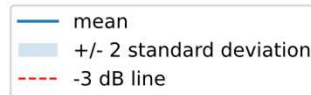

Maximum RLG is relative to the free-space boresight scenario.
 RLGHPBW= mean +/- 2 standard deviation over measured devices
 RLGHPBW measurement setup tolerance= +/- 2 degrees

LH122 + XM126 – FZP lens, D1

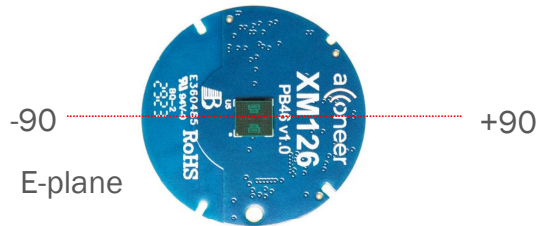
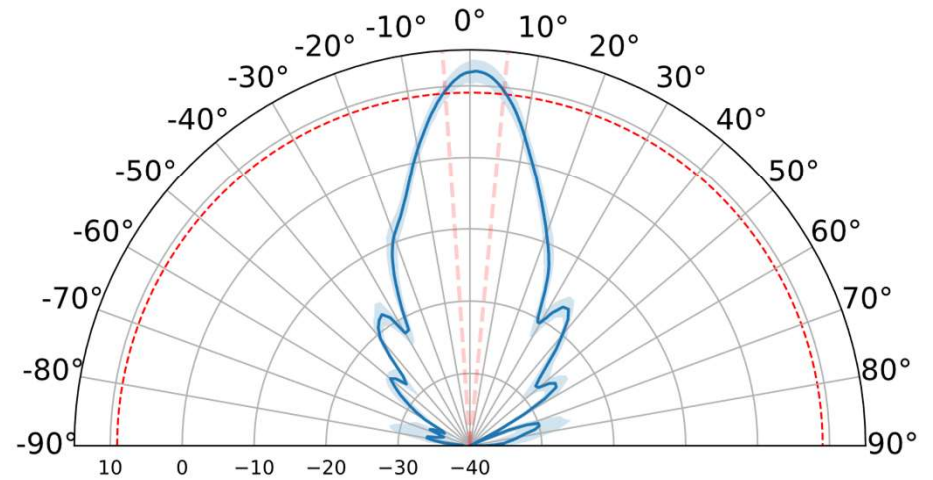
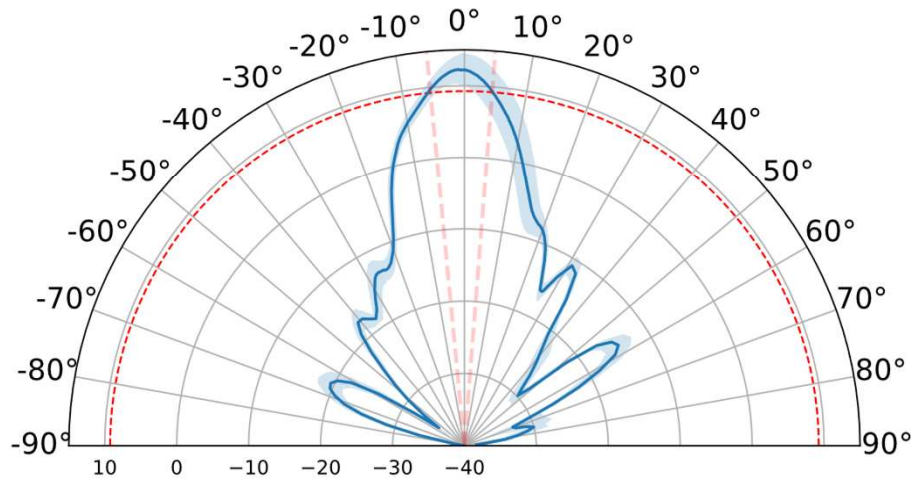
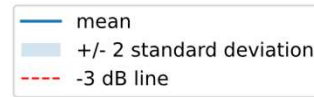

Maximum RLG is relative to the free-space boresight scenario.
 RLGHPBW= mean +/- 2 standard deviation over measured devices
 RLGHPBW measurement setup tolerance= +/- 2 degrees

LH122 + XM126 – FZP lens, D2

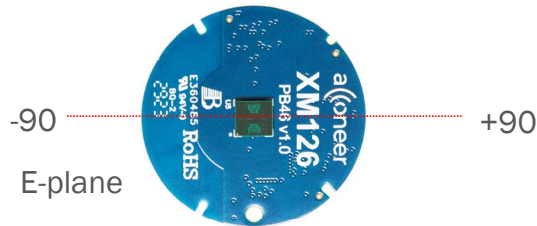
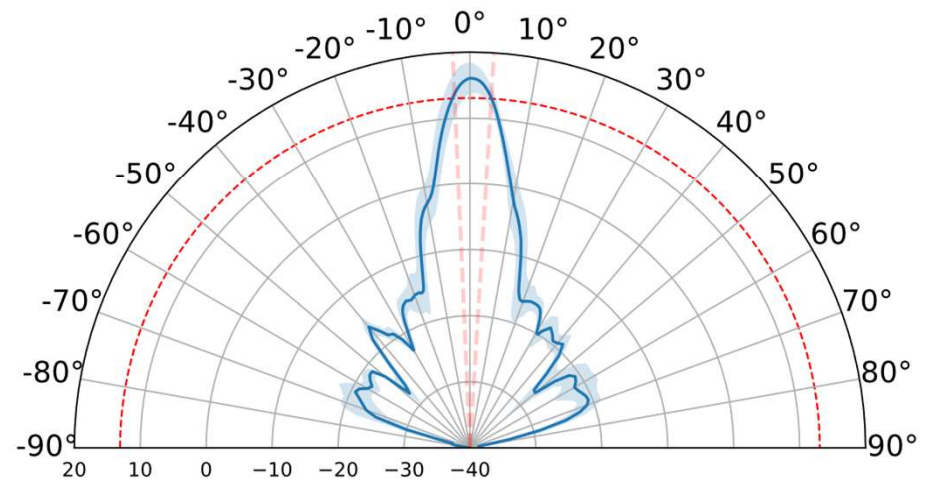
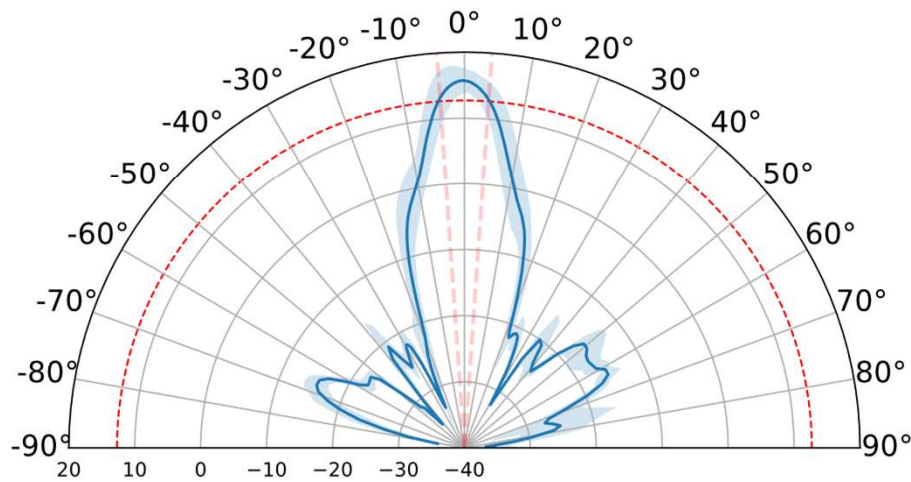
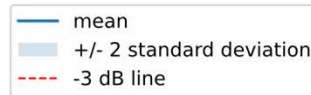

Maximum RLG is relative to the free-space boresight scenario.
 RLGHPBW= mean +/- 2 standard deviation over measured devices
 RLGHPBW measurement setup tolerance= +/- 2 degrees

LH112 + XS121 – flat cover, D1

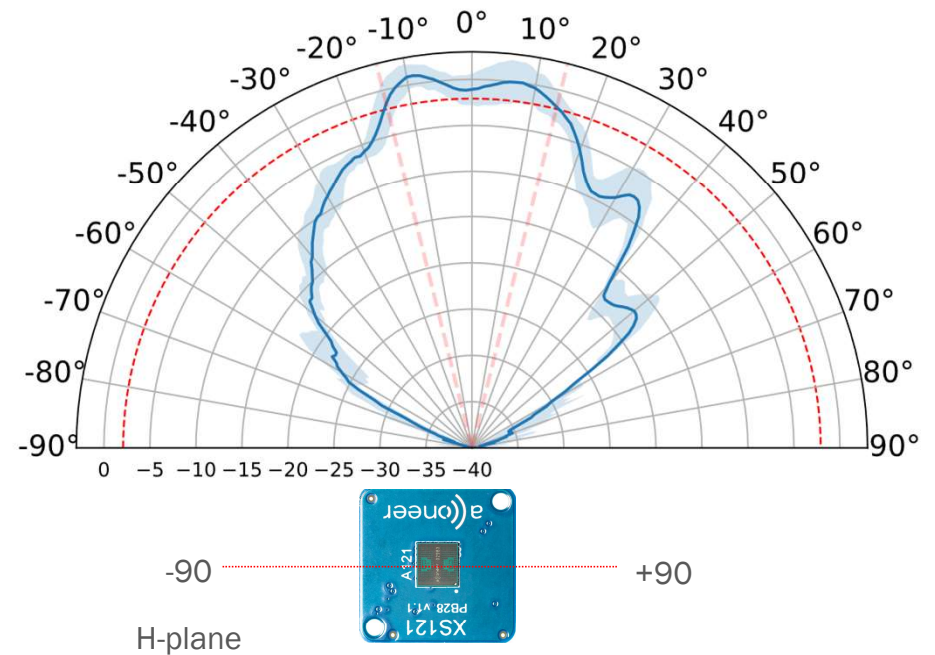
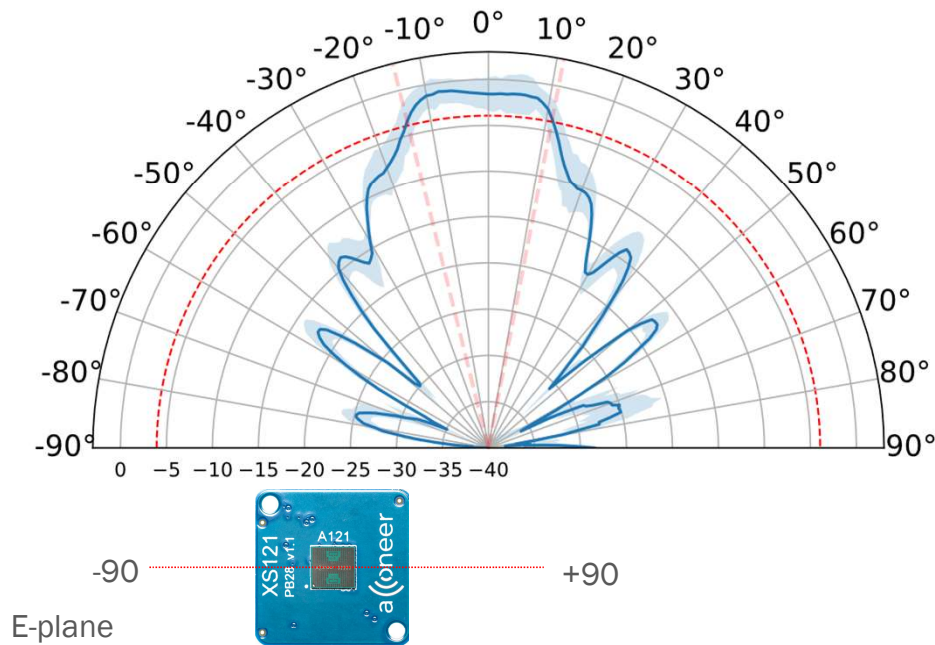
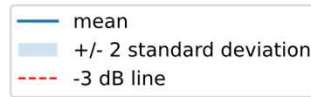

Max RLG is relative to the free-space boresight scenario.
 RLGHPBW= mean +/- 2 standard deviation over measured devices
 RLGHPBW measurement setup tolerance= +/- 2 degrees

LH120 + XE121 – flat cover, D1

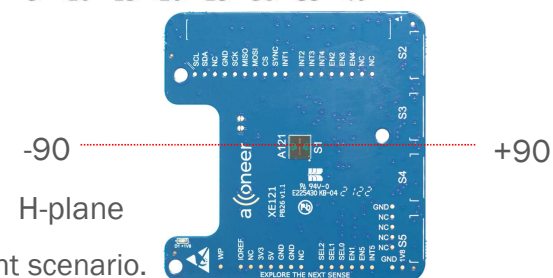
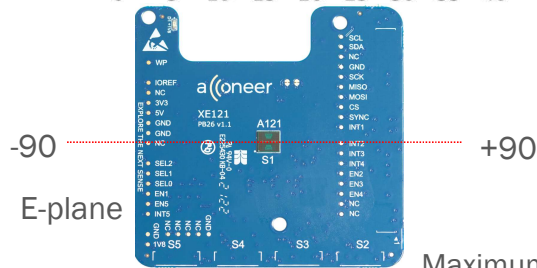
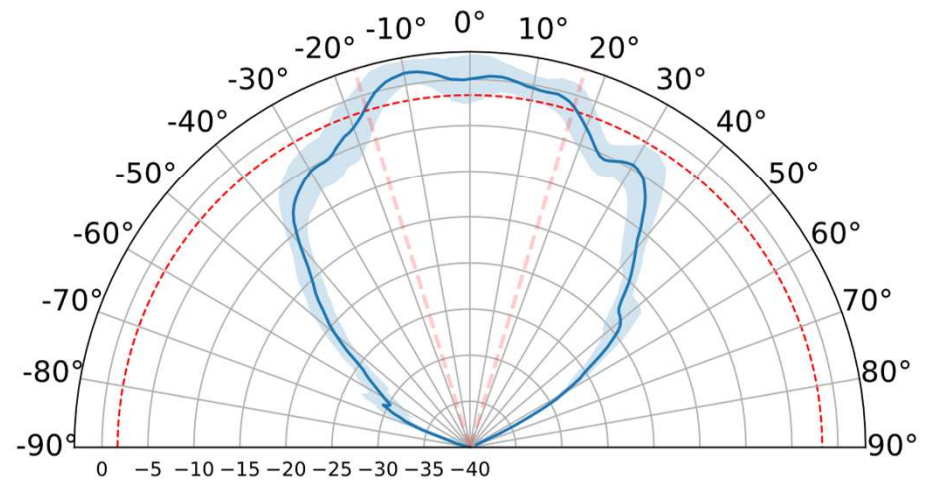
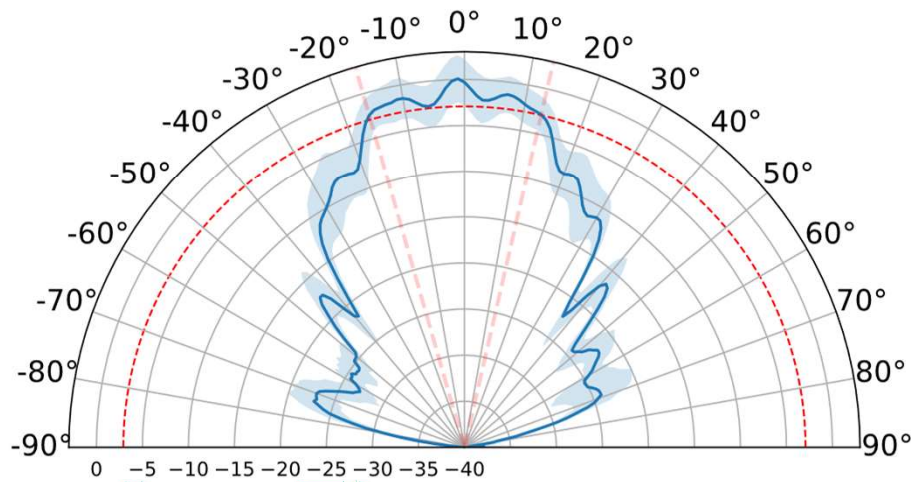
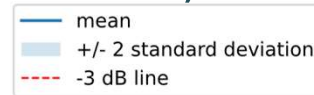

Maximum RLG is relative to the free-space boresight scenario.
 RLGHPBW= mean +/- 2 standard deviation over measured devices
 RLGHPBW measurement setup tolerance= +/- 2 degrees

LH132 + XE125 – flat cover, D1

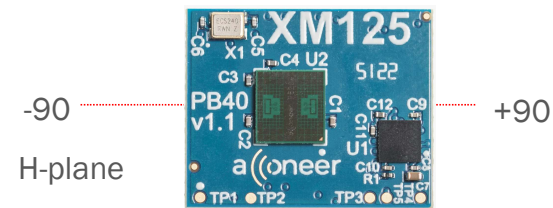
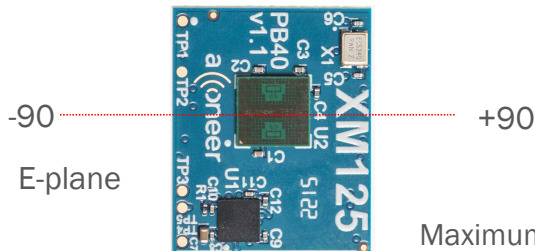
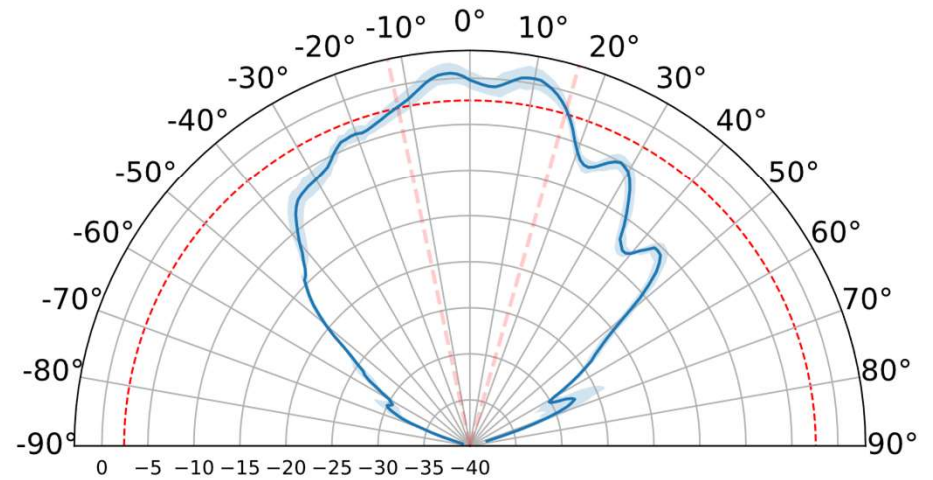
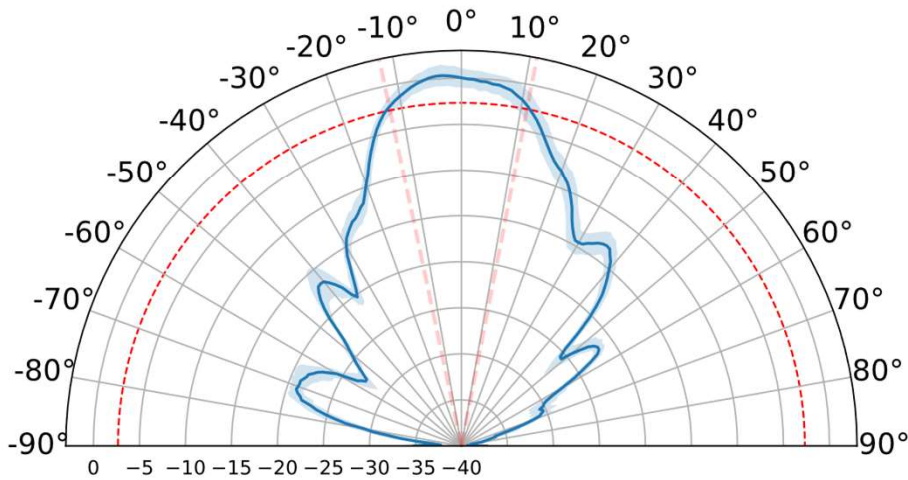
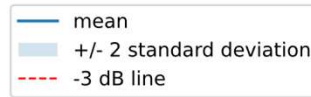

Maximum RLG is relative to the free-space boresight scenario.
 RLGHPBW= mean +/- 2 standard deviation over measured devices
 RLGHPBW measurement setup tolerance= +/- 2 degrees

LH122 + XM126 – flat cover D1

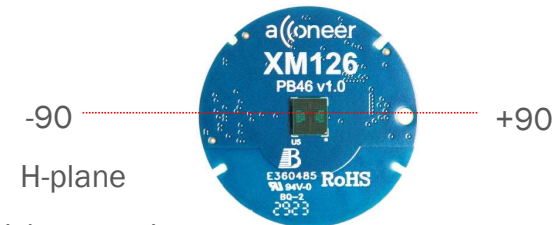
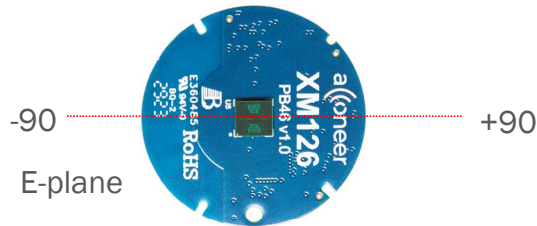
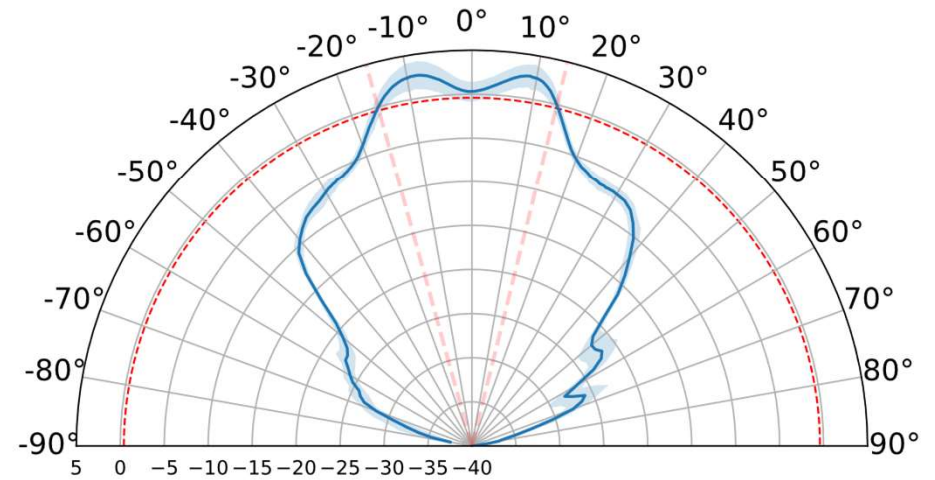
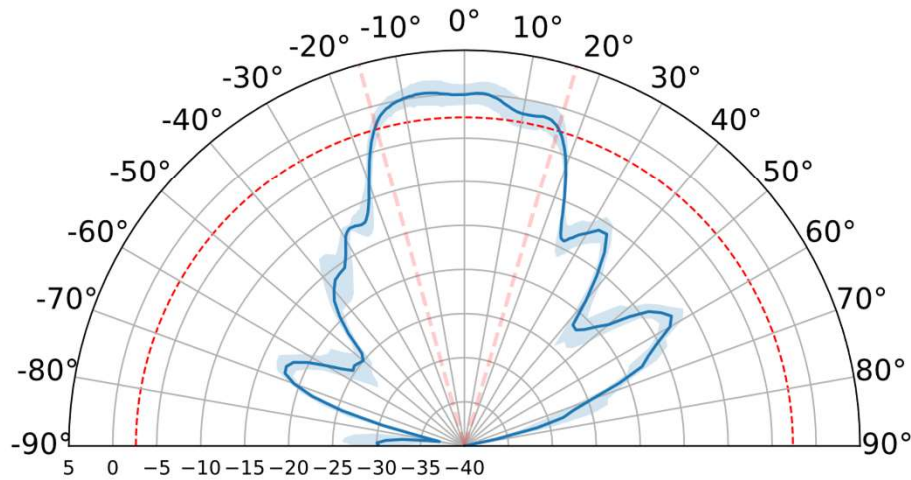

Maximum RLG is relative to the free-space boresight scenario.
 RLGHPBW= mean +/- 2 standard deviation over measured devices
 RLGHPBW measurement setup tolerance= +/- 2 degrees

Performance Table – flat cover

LH112 holder	Max RLG (dB)	RLGHPBW-E (degree)	RLGHPBW-H (degree)	LH120 holder	Max RLG (dB)	RLGHPBW-E (degree)	RLGHPBW-H (degree)
	XS121	XS121	XS121		XE121	XE121	XE121
Cover [placed at D1]	-0.9+/-1.37	27.0+/-0.2	35.80+/-8.14	Cover [placed at D1]	0.08+/-2.55	30.60+/-2.71	39.80+/-2.94

LH132 holder	Max RLG (dB)	RLGHPBW-E (degree)	RLGHPBW-H (degree)	LH122 holder	Max RLG (dB)	RLGHPBW-E (degree)	RLGHPBW-H (degree)
	XE125	XE125	XE125		XM126	XM126	XM126
Cover [placed at D1]	0.37+/-1.16	25.20+/-1.5	32.80+/-2.62	Cover [placed at D1]	0.44+/-1.43	33.50+/-1.41	35.30+/-1.74

Maximum RLG is relative to the free-space boresight scenario.
 RLGHPBW= mean +/- 2 standard deviation over measured devices
 RLGHPBW measurement setup tolerance= +/- 2 degrees

a((oneer