

# MUR2010FCT THRU MUR2060FCT

## Ultra-Fast Recovery Rectifier Diodes

### Features

- Ultra-fast recovery time for high efficiency
- Glass passivated chip junction
- Low leakage current
- High forward surge capability
- Solder dip maximum peak of 275 °C /7s, per JESD 22-B106

### Typical Application

For use in high frequency rectification and freewheeling application in switching mode converters and inverters for consumer ,computer and telecommunication.

### Mechanical Data

- Package: ITO-220AB  
Molding compound meets UL 94 V-0 flammability rating, RoHS-compliant
- Terminals: Tin plated leads, solderable per J-STD-002 and JESD22-B102
- Polarity: Color Band denotes cathode end



### Maximum Ratings (Ta=25°C Unless otherwise specified)

PARAMETER	Symbol	Unit	Conditions	MUR-FCT				
				2010	2015	2020	2040	2060
Repetitive Peak Reverse Voltage	$V_{RRM}$	V		100	150	200	400	600
Average Forward Current	$I_O$	A	60HZ Half-sine wave, Resistance load, Tc(Fig.1)	20				
Surge(Nonrepetitive)Forward Current	$I_{FSM}$	A	60HZ sine wave, 1 cycle, Ta=25°C	125				
Current Squared Time	$I^2 t$	A <sup>2</sup> s	1ms≤t<8.3ms Tj=25°C, Rating of per diode	65				
Storage Temperature	$T_{stg}$	°C		-55 ~ +150				
Junction Temperature	$T_j$	°C		-55 ~ +150				

### Electrical Characteristics (Ta=25°C Unless otherwise specified)

PARAMETER	Symbol	Unit	Conditions	MUR-FCT				
				2010	2015	2020	2040	2060
Peak Forward Voltage	V <sub>FM</sub>	V	I <sub>FM</sub> =10.0A	0.975			1.35	1.7
Peak Reverse Current	I <sub>RRM1</sub>	μA	V <sub>RM</sub> =V <sub>RRM</sub>	Ta=25°C				
	I <sub>RRM2</sub>			Ta=125°C				
Maximum reverse recovery time	T <sub>rr</sub>	ns	I <sub>F</sub> =0.5A, I <sub>R</sub> =1.0A, I <sub>rr</sub> =0.25A	35				
Thermal Resistance	R <sub>θJ-C</sub>	R <sub>θJ-C</sub>	Between junction and case	2.0				



# MUR2010FCT THRU MUR2060FCT

■ Characteristics (Typical)

FIG1: Forward Current Derating Curve

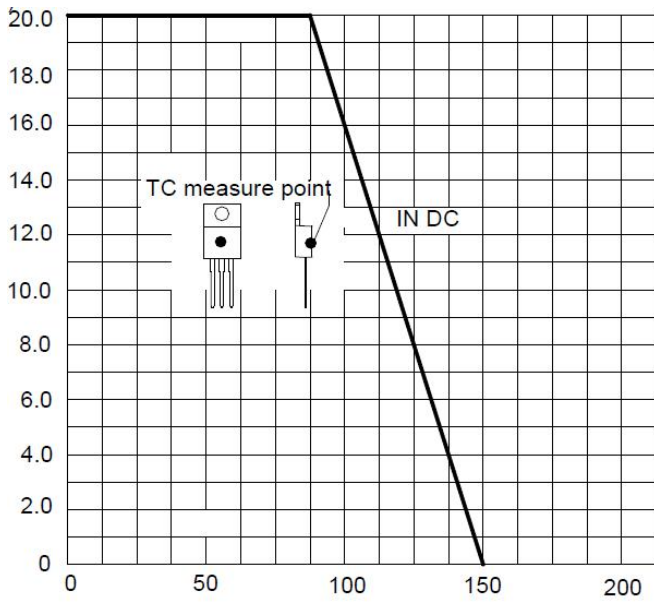

FIG2: Surge Forward Current Capability

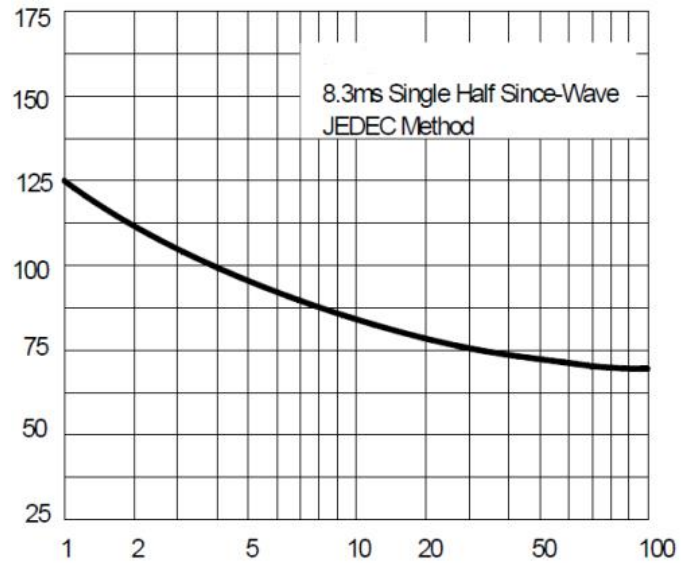

FIG3: Instantaneous Forward Voltage

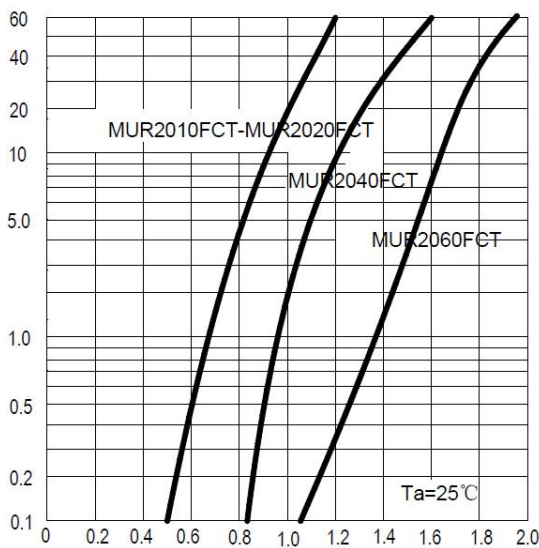

FIG4: Typical Reverse Characteristics

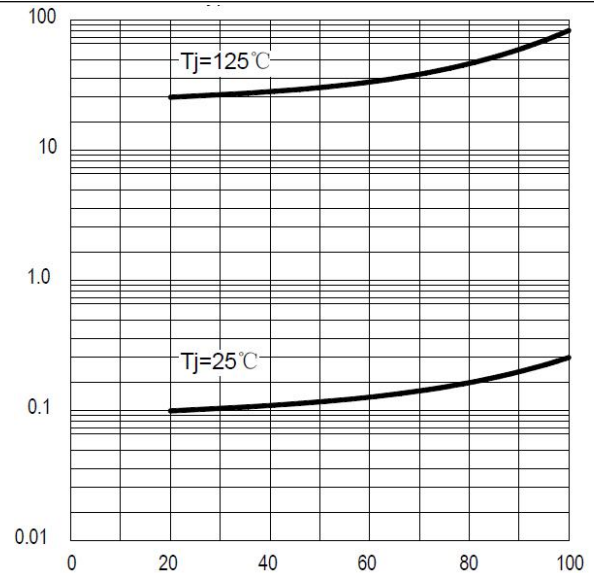
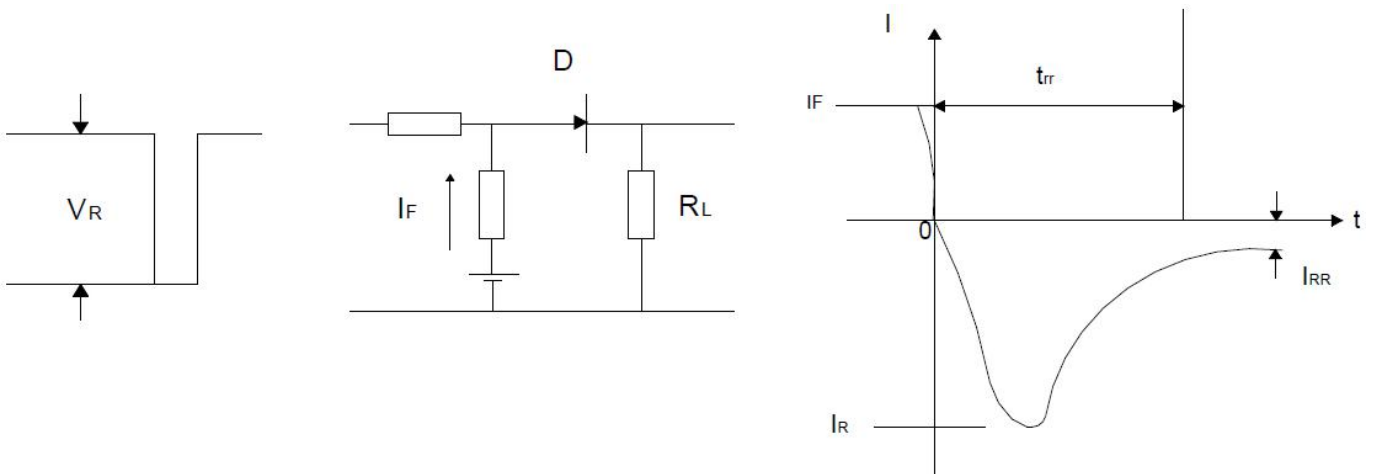

FIG5: Diagram of circuit and Testing wave form of reverse recovery time



## MUR2010FCT THRU MUR2060FCT

### Ordering Information (Example)

PREFERED	PACKAGE CODE	MINIMUM PACKAGE(pcs)	INNER BOX QUANTITY(pcs)	OUTER CARTON QUANTITY(pcs)	DELIVERY MODE
MUR2010FCT~MUR2060FCT	ITO-220AB	50	1000	5000	Tube

### Outline Dimensions

