

REVISIONS					
REV	ECO	DESCRIPTION	DATE	BY	APPR
A1	-	RELEASED DRAWING	OCT-17-2018	FLAN	TOMMY
A2	-	UPDATE RATED VOLTAGE	NOV-11-2022	JUN	TOMMY

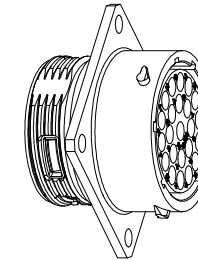

NOTES:

- MATERIAL:
SHELL: ZINC ALLOY, NICKEL PLATED.
INSERT: THERMOPLASTIC, UL94 V-0.
SEAL GASKET: NBR/SILICONE RUBBER.
O-RING: NBR/SILICONE RUBBER.
- SPECIFICATIONS:
2.1 RATED CURRENT: 13A (MAX).
2.2 RATED VOLTAGE: 500V (AC/DC) .
2.3 OPERATING TEMPERATURE: SEE CHART.
2.4 DIELECTRIC WITHSTANDING VOLTAGE: LESS THAN 2 MILLIAMPS CURRENT LEAKAGE@2000 VOLTS AC.
2.5 INSULATION RESISTANCE: 5000 MEGOHMS MIN.
2.6 IP--CLASS: IP67 AND IP69K.
2.7 MATING CYCLES DURABILITY: 500 CYCLES MIN.
2.8 RoHS COMPLIANT.
- SUITABLE CONTACTS : 16# CONTACTS.
- ALL DIMENSIONS ARE FOR REFERENCE USE ONLY.

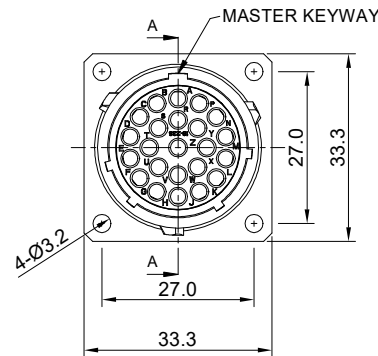
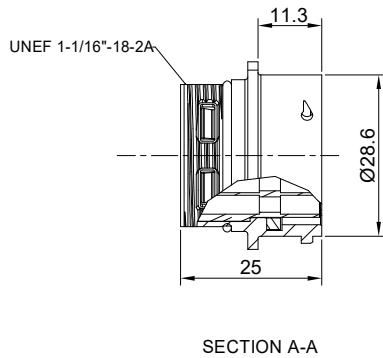
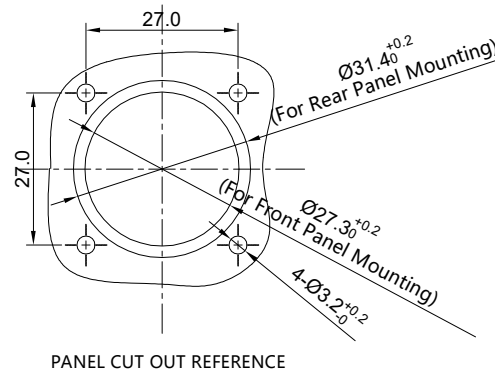

KEY POS	PART NUMBER	
	-40°C~105°C	-40°C~125°C
N	RT001823SKNH	RT001823SKNH03
W	RT001823SKWH	RT001823SKWH03
X	RT001823SKXH	RT001823SKXH03
Y	RT001823SKYH	RT001823SKYH03
Z	RT001823SKZH	RT001823SKZH03

QUANTITY	SEE PART NUMBER CHART	PART NUMBER	DESCRIPTION	ITEM
MATERIALS LIST				
UNLESS OTHERWISE SPECIFIED		SIGNATURES		DATE
1) All dimensions are in metric(mm).		DRAWN: JUN		NOV-11-2022
2) Tolerances are as follows:		CHECKED: ORION		DEC-12-2022
1 PL DEC ±0.30		ENGINEER:		
2 PL DEC ±0.15		APPROVAL: TOMMY		DEC-14-2022
3 PL DEC ±0.08		CUSTOMER:		
3) Note reference =		THIS DRAWING IS SUPPLIED FOR INFORMATION ONLY. DESIGN FEATURES, SPECIFICATIONS AND PERFORMANCE DATA SHOWN HEREON ARE THE PROPERTY OF THE AMPHENOL CORPORATION. NO RIGHTS OF REPRODUCTION ARE IMPLIED. ALL DIMENSIONS ARE SUBJECT TO NORMAL MANUFACTURING VARIATIONS.		
MATERIAL SPECIFICATIONS:		ECO-MATE, RECEPTACLE, SIZE 18, 23 POS, SOCKET		
PROCESS SPECIFICATIONS:		SIZE TYPE DWG NO. REVISION		
NEXT ASSY:		B C- RT001823SK*H* A2		
		SCALE NONE SHEET 1 OF 1		

TITLE: ECO-MATE RECEPTACLE SIZE 18,23POS SOCKET
DWG NO.: RT001823SK*H*
REV: A2
SH: 1
OF: 1