

REV.	DESCRIPTION	NAME	DATE
X1	NEWS ISSUE	李春风	2020/03/13

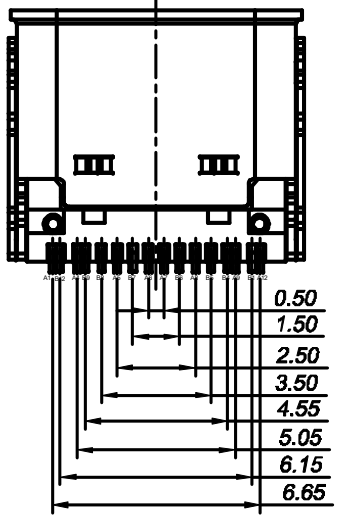
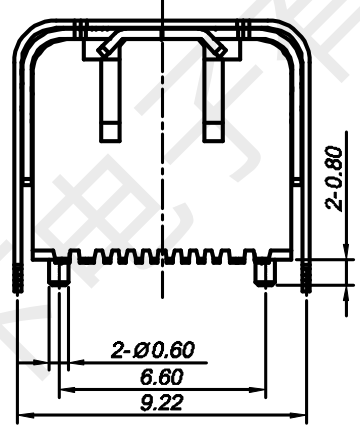
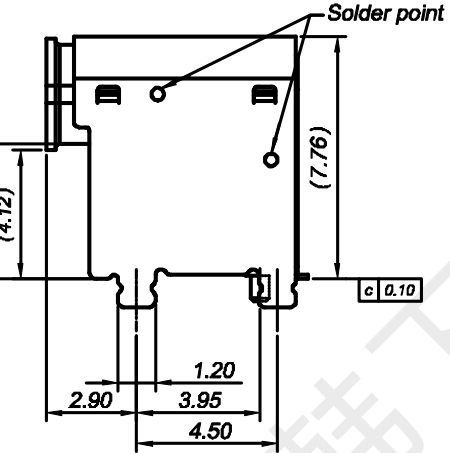
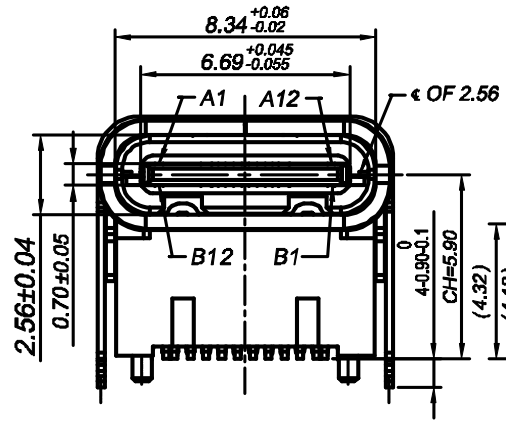
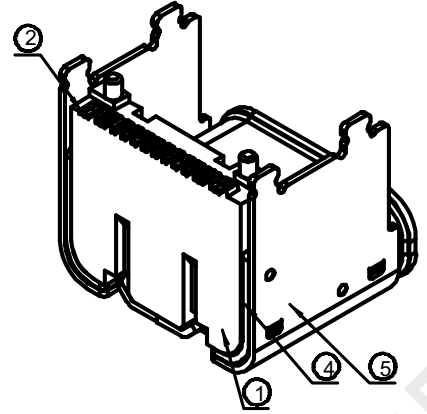
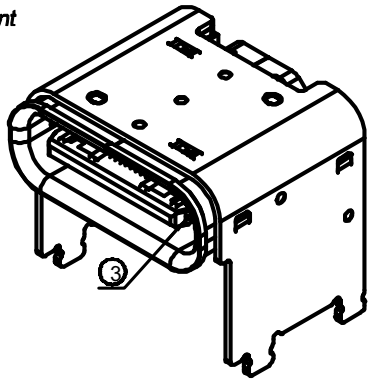
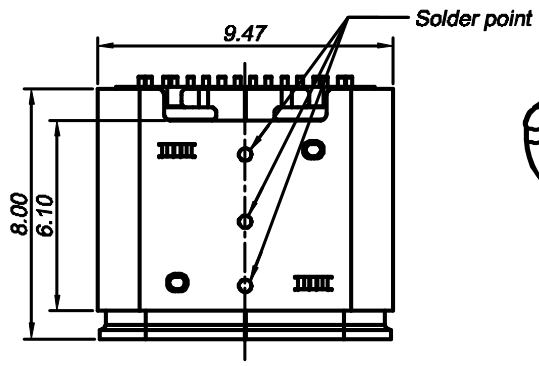

规格说明 Specifications:

1. 电气特性 Electrical:
 - 额定电压 (Rated voltage): 20V DC
 - 额定电流 (Rated current): 5A VBUS引脚; 1.25A用于GND引脚, 其他引脚为0.25A.
 - 接触电阻 (Contact resistance): 40mΩ Max
 - 测试条件: 20mv, 100mA下测量.
 - 绝缘电阻 (Insulation resistance): 100MΩ Min
 - 耐电压 (Withstand Voltage): 100V AC
2. 机械性能 Mechanical:
 - 插入力 (Mate force): 0.5-2.0Kg
 - 拔出力 (Unmate force): 0.6-2.0Kg
 - 插拔次数 (Durability): 10000 Cycles.
3. 材料 Material:
 - 胶芯 (Housing): LCP UL94 V-0
 - 端子 (Contact): C2680, T=0.2mm; 镍底, 镀金
 - 外壳 (Shell): 不锈钢201-H 表面镀镍
4. 温度范围 (Temperature Range): -30°C to +80°C.

TOLERANCE UNSPECIFIED

.0	±0.35
.00	±0.25
.000	±0.15
X.°	±2.00°

CUSTOMER DRAWING

韩下 HANXIA 深圳市韩下电子有限公司

TITLE: HX TYPE-C 16P+4.3

DRAWN DATE	黄彬 2020/03/13	SIZE: A4	UNIT: mm.	PART. NO:	UCR04-0161X-00XR
CHECKED DATE	张伟 2020/03/13	SCALE: 1:1	PROJECTION		REV.: X1
APPROVED DATE	罗小春 2020/03/13	DWG PATH	C00-0000-0064		PATH 1/3