

THIS DOCUMENT IS THE PROPERTY OF KEYSTONE ELECTRONICS CORP. AND SHALL NOT BE REPRODUCED, DISTRIBUTED OR USED AS A BASIS FOR MANUFACTURE WITHOUT PRIOR WRITTEN PERMISSION FROM KEYSTONE ELECTRONICS CORP.

**MOUNTING PAD LAYOUT**

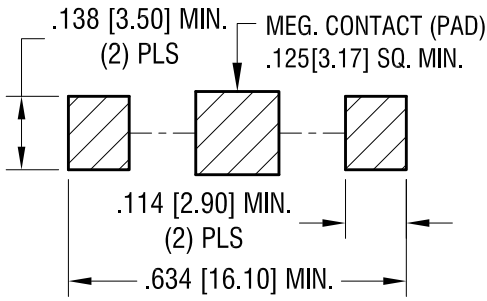

ACTUAL SIZE

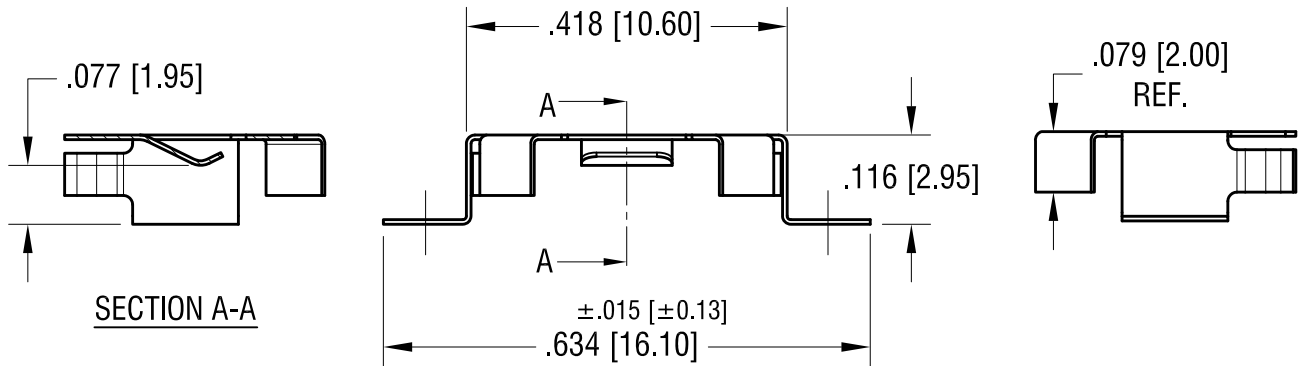
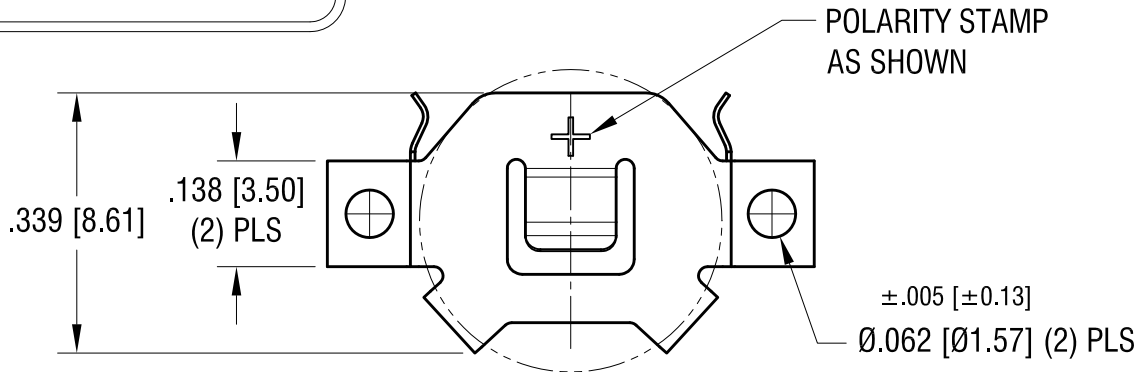

			<b>KEYSTONE ELECTRONICS CORP.</b>		
			www.keyelco.com • NEW HYDE PARK, NY 11040 • Tel (516) 328-7500		
PART NAME			10mm SM COIN CELL CLIP		
MATERIAL			.006 [0.15] TH'K PHOSPHOR BRONZE		
2.29.24	NO CHANGES TO PART	C	FINISH	DRN BY	DATE
3.31.21	POLARITY STAMP WAS CUT THRU MA'L CHANGE AS PER ECN 21-032	B		NT	9.17.10
12.27.16	CHANGE AS PER ECN 16-115	A	MATTE TIN PLATE	APP'D	SCALE
DATE	DESCRIPTION	REV.	TOLERANCES INCH [MM]	CODE	DWG NO.
			DECIMAL ±.010 [±0.25]	C	<b>3050</b>
			ANGULAR ± 1°		
			UNLESS OTHERWISE SPECIFIED		