

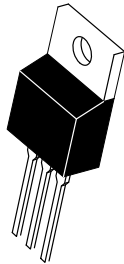

# MBR6020CT THRU MBR60200CT

## 60.0 AMP SCHOTTKY BARRIER RECTIFIERS



### FEATURES

- \* Low forward voltage drop
- \* High current capability
- \* High reliability
- \* High surge current capability
- \* Good for switching mode application

### MECHANICAL DATA

- \* Case: Molded plastic
- \* Epoxy: UL 94V-0 rate flame retardant
- \* Lead: Lead solderable per MIL-STD-202, method 208 guaranteed
- \* Polarity: As Marked
- \* Mounting position: Any

### VOLTAGE RANGE

20 to 200 Volts

### CURRENT

60.0 Amperes

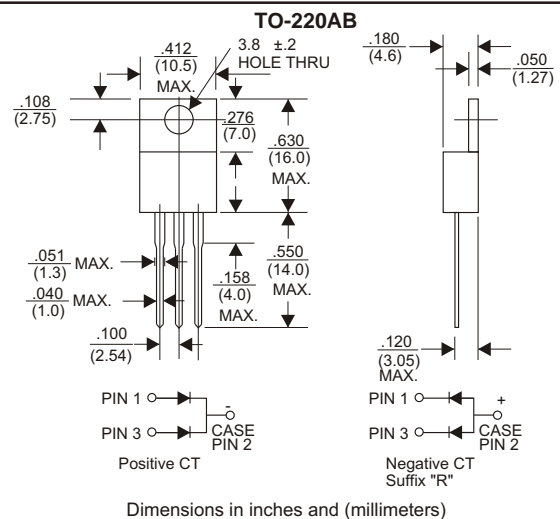

## MAXIMUM RATINGS AND ELECTRICAL CHARACTERISTICS

Rating 25°C ambient temperature unless otherwise specified.  
Single phase half wave, 60Hz, resistive or inductive load.  
For capacitive load, derate current by 20%.

TYPE NUMBER	MBR6020CT	MBR6045CT	MBR6060CT	MBR6080CT	MBR60100CT	MBR60150CT	MBR60200CT	UNITS
Maximum Recurrent Peak Reverse Voltage	20	45	60	80	100	150	200	V
Maximum RMS Voltage	14	32	42	56	70	105	140	V
Maximum DC Blocking Voltage	20	45	60	80	100	150	200	V
Maximum Average Forward Rectified Current	60							A
Peak Forward Surge Current, 8.3 ms single half sine-wave superimposed on rated load (JEDEC method)	500							A
Maximum Instantaneous Forward Voltage at 30.0A	0.60	0.75	0.85		0.92			V
Maximum DC Reverse Current Ta=25°C	0.1		0.02					mA
at Rated DC Blocking Voltage Ta=100°C	5		2					mA
Typical Junction Capacitance (Note1)	580							pF
Typical Thermal Resistance RθJC (Note 2)	2.5							°C/W
Operating Temperature Range Tj	-65 — +150							°C
Storage Temperature Range Tstg	-65 — +150							°C

#### NOTES:

1. Measured at 1MHz and applied reverse voltage of 4.0V D.C.
2. Thermal Resistance Junction to Case.

## RATING AND CHARACTERISTIC CURVES (MBR6020CT THRU MBR60200CT)

FIG.1-TYPICAL FORWARD CURRENT DERATING CURVE

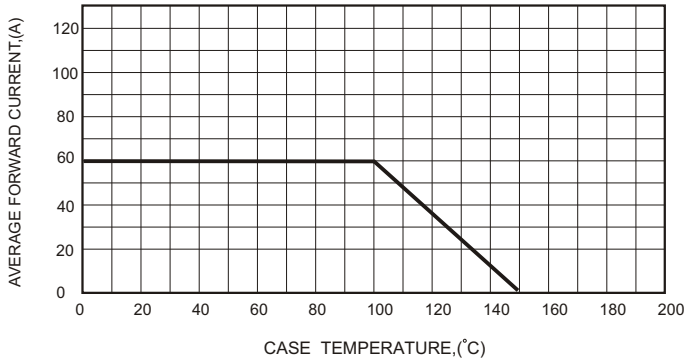

FIG.2-TYPICAL FORWARD CHARACTERISTICS

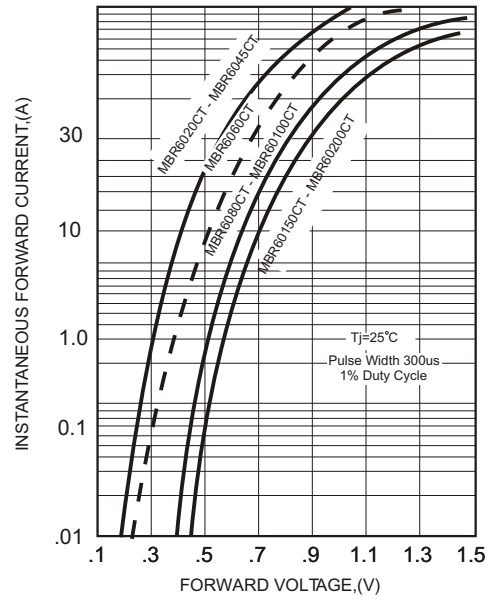

FIG.3-MAXIMUM NON-REPETITIVE FORWARD SURGE CURRENT

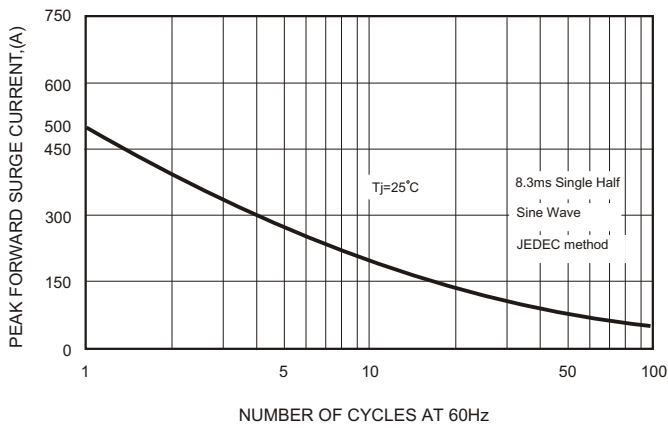

FIG.4-TYPICAL JUNCTION CAPACITANCE

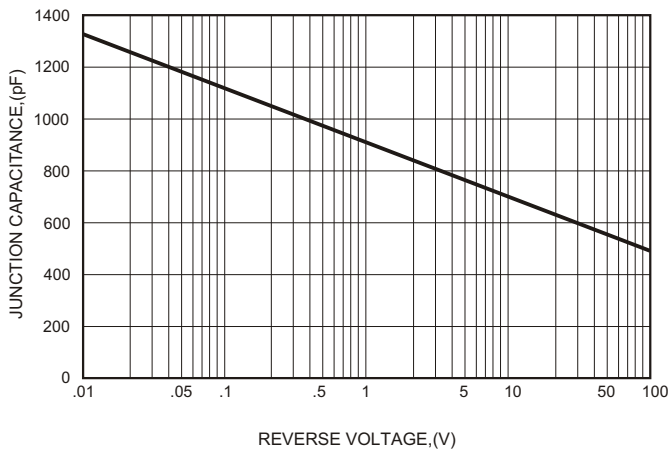

FIG.5 - TYPICAL REVERSE CHARACTERISTICS

