

## SS32 thru SS320 SMA

### FEATURES

- For surface mounted applications
- Metal silicon junction, majority carrier conduction
- Low power loss, high efficiency
- Built-in strain relief, ideal for automated placement
- High forward surge current capability
- High temperature soldering guaranteed: 250 °C/10 seconds at terminals
- The plastic package carries Underwriters Laboratory Flammability Classification 94V-0

### Mechanical Data

- Case: JEDEC DO-214AC molded plastic
- Terminals: leads solderable per MIL-STD-750, Method 2026
- Mounting Position: Any
- Polarity: Color band denotes cathode end
- Weight: 0.005 ounce, 0.138 grams



### Major Ratings and Characteristics

$I_{F(AV)}$	3.0A
$V_{RRM}$	20 V to 100 V
$I_{FSM}$	100A
$V_F$	0.55V, 0.70V, 0.85V
$T_{j\ max.}$	125 °C

### Maximum Ratings & Thermal Characteristics

(TA = 25 °C unless otherwise noted)

Items	Symbol	SS32	SS33	SS34	SS35	SS36	SS38	SS310	Unit
Maximum repetitive peak reverse voltage	$V_{RRM}$	20	30	40	50	60	80	100	V
Maximum RMS voltage	$V_{RMS}$	14	21	28	35	42	56	70	V
Maximum DC blocking voltage	$V_{DC}$	20	30	40	50	60	80	100	V
Maximum average forward rectified current	$I_{F(AV)}$	3.0							A
Peak forward surge current 8.3ms single half sine-wave superimposed on rated load	$I_{FSM}$	100							A
Thermal resistance from junction to lead <sup>(1)</sup>	$R_{\theta JL}$	55							°C/W
Operating junction and storage temperature range	$T_J, T_{STG}$	-65 TO +125							°C

Note 1: Mounted on P.C.B. with 0.2 x 0.2" (5.0 x 5.0mm) copper pad areas.

**Electrical Characteristics (TA = 25 °C unless otherwise noted)**

Items	Test conditions	Symbol	SS32~SS34	SS35~SS36	SS38~SS310	UNIT
Instantaneous forward voltage	IF=3.0A <sup>(2)</sup>	V <sub>F</sub>	0.55	0.70	0.85	V
Reverse current	V <sub>R</sub> =V <sub>DC</sub>	T <sub>J</sub> =25°C	0.5			mA
		T <sub>J</sub> =100°C	20	10		
Typical junction capacitance	4.0 V ,1MHz	C <sub>J</sub>	500	300		pf

Note 2: Pulse test:300μs pulse width,1% duty cycle.

**Typical Characteristics**

Fig.1 Forward current derating curve

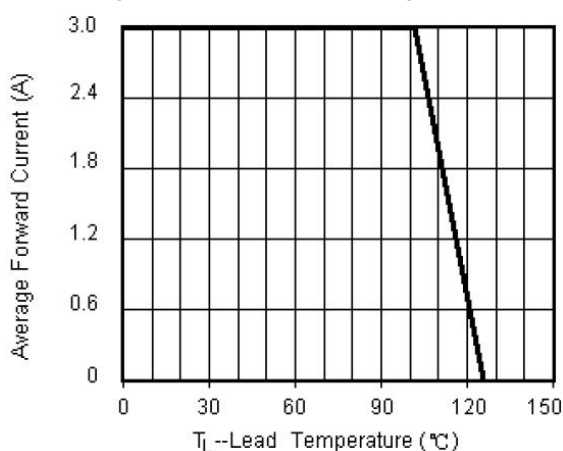

Fig.2 Maximum non-repetitive peak forward surge current

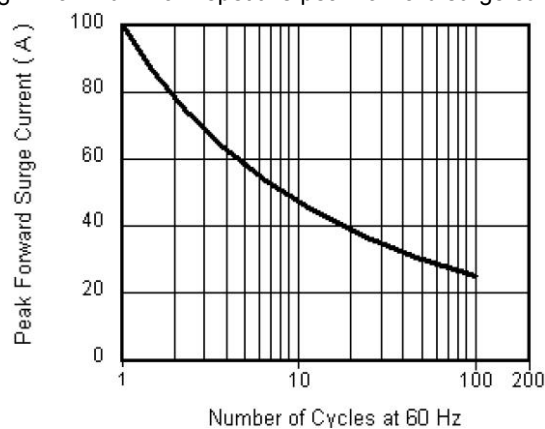

Fig.3 Typical instantaneous forward characteristics

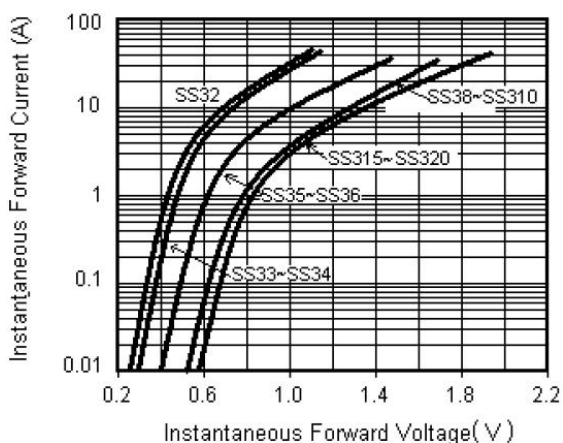
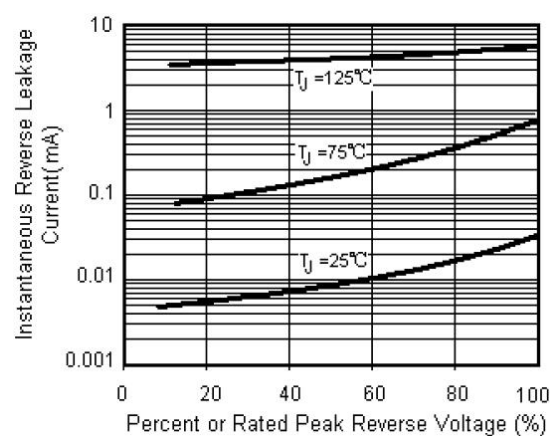
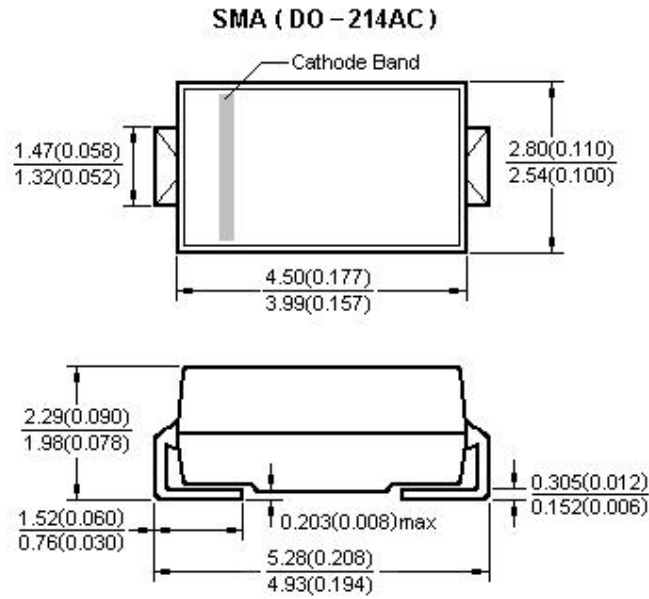

Fig.4 Typical reverse leakage characteristics



Package Outline(SMA DO-214AC)



Dimensions in millimeters and (inches)

**Disclaimer**

Specifications are subject to change without notice.

The device characteristics and parameters in this data sheet can and do vary in different applications and actual device performance may vary over time.

Users should verify actual device performance in their specific applications.