

# S85049/69 Connector Accessories

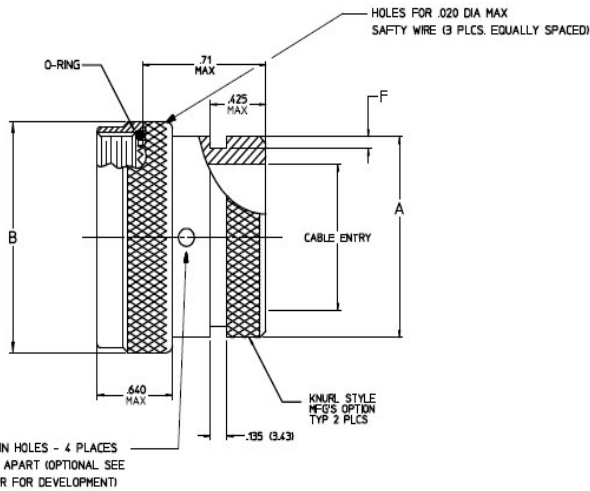

**Straight Shrink Boot Adapter**

## Shrink Boot Adapters

The adapters in this section are designed to accommodate lipped-type heat shrinkable boots, which are used for both mechanical strain relief and a degree of environmental protection.

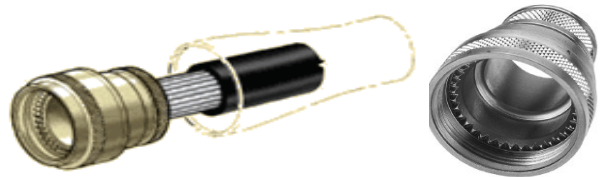

## Part Number Construction

**S85049/ 69 - 15 A D - 234**

Basic Part Number Prefix  
for Mil-DTL-38999 Connector

Shell Size see Table II

Plating Code See Table I  
Drain Holes Option  
Omit for none

Material / Finish\*

TABLE I – Plating Codes

Designator	Finish	Specification
212	Electroless Nickel	ASTM B733-90, SC3, Type 1, Class 5, With iridized Seal.
234	Cadmium Plate, Olive Drab	QQ-P-416, Type II, Class 3, Olive Drab Color Chromate Conversion Over Electroless Nickel.
298D	Zinc Cobalt	(Zinc Alloy C Process) with Dark Olive Drab Chromate Conversion Over Electroless Nickel.,

\*Material / Finish - Adapter Components Aluminum Alloy/Black Anodize  
Hardware - SST / Passivated  
O-Ring - Silicon / N/A

Note: All dimension are in millimeters unless otherwise specified.

TABLE II

Shell size		A Max. Dia.	B Max. Dia.	F +008 -000	Cable Entry Max. Dia.
Commercial	Military				
9	A	13.5	19.1	1.12	6.4
11	B	15.4	21.6	1.12	9.0
13	C	19.7	25.4	1.12	12.5
15	D	21.3	29.2	1.12	14.4
17	E	24.5	31.8	1.12	17.5
19	F	26.5	35.6	1.12	19.5
21	G	30.9	39.4	1.75	22.7
23	H	34.4	41.9	1.75	25.9
25	J	36.7	47.0	1.75	28.8

Note: All dimension are in millimeters unless otherwise specified.