

## 2MHz, 1.5A Flash LED Driver in 2x3mm Package

### Features

- Input voltage range: 2.7V to 5.5V
- Dual Flash LED outputs
- Drive up to total 1.5A or 0.75A per channel
- High efficiency converter (up to 95%)
- 2MHz step-up converter
- Very small inductor: 1.0 $\mu$ H
- Very small load capacitor: 4.7 $\mu$ F to 10 $\mu$ F
- Independent flash-mode enable and movie/torch-mode enable pins
- Movie/torch-mode dimming via PWM control
- One resistor sets flash-mode LED current
- One resistor sets movie/torch-mode LED current
- Integrated thermal regulation control
- LED open/short protection
- Over-voltage protection
- Cycle-by-cycle inductor current limit
- 0.1 $\mu$ A shutdown current
- Pb-free Package: TDFN2x3-14
- -40°C to +85°C Temperature Range

### Applications

- Mobile Phones
- Smart Phones and PDAs
- Digital Still Cameras

### Brief Description

The KTD267 is the ideal power solution for high-power flash LEDs used with cell phone camera modules or digital still cameras. It is a highly integrated step up DC-DC converter with very high switching frequency, fixed at 2MHz, providing a very small total solution for portable photo flash. The KTD267 has separate flash-mode and movie/torch-mode enable pins for maximum flexibility. The flash-mode and movie/torch-mode LED current is programmed by external resistors respectively, making the flash LED solution simple to control. If both enable pins are at logic high, the LED current will be programmed by the movie/torch-mode setting resistor.

The two LED output sinks can be shorted together externally for higher power single flash LEDs, up to 1.5A continuous LED current. Thermal regulation is integrated in flash mode to limit the IC's temperature and continuously provide the maximum allowed output current.

Various protection features are built into the KTD267, including cycle-by-cycle input current limit protection, output over-voltage protection, LED fault (open or short) protection and thermal shutdown protection. The leakage current in shutdown mode is 0.1 $\mu$ A.

The KTD267 is available in a RoHS compliant 14-lead 2x3x0.75mm ThinDFN.

### Typical Application

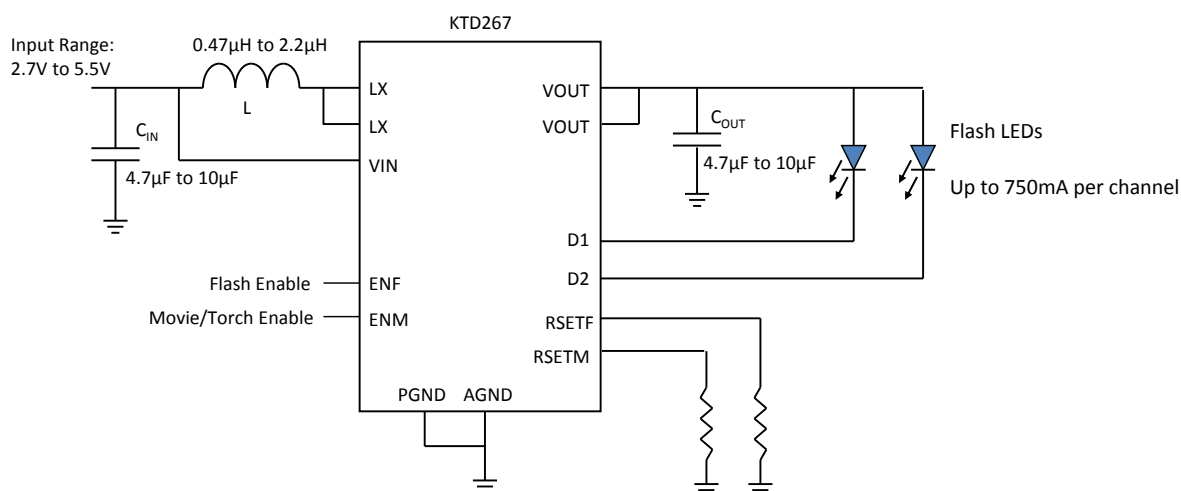

**Pin Descriptions**

**TDFN2x3-14**

Pin #	Name	Function
1	RSETM	Movie/torch-mode current setting pin
2	RSETF	Flash-mode current setting pin
3, 13	AGND	Analog Ground pin
4	VIN	Input supply pin for the IC
5, 6	LX	Switching node of the step-up converter
7	PGND	Power Ground pin
8, 9	VOUT	Output voltage pin
10	ENF	Flash-mode enable pin. This pin has an internal 300kΩ pull-down resistor to AGND.
11	ENM	Movie/torch-mode enable pin. This pin has an internal 300kΩ pull-down resistor to AGND.
12	D1	Regulated output current sink #1, up to 0.75A current. Pins D1 and D2 can be connected together to sink 1.5A combined.
14	D2	Regulated output current sink #2, up to 0.75A current. Pins D1 and D2 can be connected together to sink 1.5A combined.
	MC	Metal chassis. Connect to ground for electrical and thermal usage. MC is internally connected to Analog Ground pin.

**TDFN2x3-14  
(Top View)**

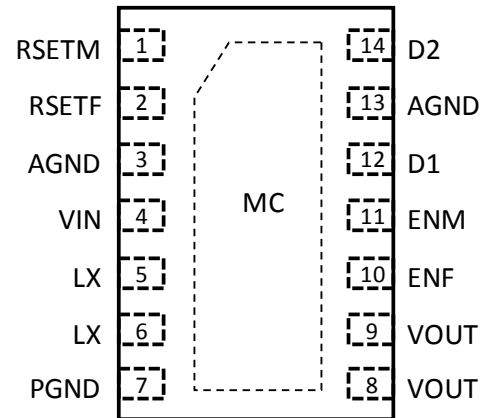

## Absolute Maximum Ratings <sup>1</sup>

(T<sub>A</sub> = 25°C unless otherwise noted)

Symbol	Description	Value	Units
V <sub>IN</sub> , V <sub>OUT</sub> , D1, D2	Input voltage, output pins	-0.3 to 6	V
ENF, ENM, RSETF, RSETM	Control pins	-0.3 to V <sub>IN</sub> +0.3	V
LX	Switching node	-0.3 to 6.5	V
T <sub>J</sub>	Operating Temperature Range	-40 to 150	°C
T <sub>s</sub>	Storage Temperature Range	-65 to 150	°C
T <sub>LEAD</sub>	Maximum Soldering Temperature (at leads, 10 sec)	300	°C
ESD	HBM electrical static discharge	2.0	kV

1. Stresses above those listed in Absolute Maximum Ratings may cause permanent damage to the device. Functional operation at conditions other than the operating conditions specified is not implied. Only one Absolute Maximum rating should be applied at any one time.

## Thermal Capabilities

Symbol	Description	Value	Units
θ <sub>JA</sub>	Thermal Resistance – Junction to Ambient <sup>2</sup>	78	°C/W
P <sub>D</sub>	Maximum Power Dissipation at T <sub>A</sub> axim°C	1.28	W
ΔP <sub>D</sub> /ΔT	Derating Factor Above T <sub>A</sub> = 25°C	-12.8	mW/°C

2. Junction to Ambient thermal resistance is highly dependent on PCB layout. Values are based on thermal properties of the device when soldered to an EV board.

## Recommended Operating Range

Description	Value
V <sub>IN</sub> , V <sub>OUT</sub> , D1 and D2 Voltages	2.7V – 5.5V
LX Voltage	≤6V

## Ordering Information

Part Number	Marking <sup>3</sup>	Operating Temperature	Package
KTD267EJH-TR	CQYYZ	-40°C to +85°C	TDFN23-14

3. “YYZ” is the date code and assembly code.

**Electrical Characteristics <sup>4</sup>**

Unless otherwise noted, the *Min* and *Max* specs are applied over the full operation temperature range of  $-40^{\circ}\text{C}$  to  $+85^{\circ}\text{C}$ , while *Typ* values are specified at room temperature ( $25^{\circ}\text{C}$ ).  $V_{\text{IN}} = 3.6\text{V}$ .

Symbol	Description	Conditions	Min	Typ	Max	Units
<b>IC Supply</b>						
$V_{\text{IN}}$	Input operating range		2.7		5.5	V
UVLO	Input under voltage lockout	Rising edge	2.1	2.4	2.68	V
UVLO <sub>HYST</sub>	UVLO hysteresis			0.1		V
$I_{\text{Q}}$	IC operating current	Not switching		1.0	1.6	mA
	IC operating current	Switching		1.1	2.5	mA
$I_{\text{SHDN}}$	VIN pin shutdown current	ENF = ENM = GND		0.1	1	$\mu\text{A}$
<b>Step-Up Converter</b>						
$I_{\text{LIM}}$	Peak NMOS current limit			3.5		A
$F_{\text{SW}}$	Oscillator frequency			2.0		MHz
$D_{\text{MAX}}$	Maximum duty cycle			75		%
$V_{\text{OVP}}$	Internal OV threshold of VOUT			5.3		V
$T_{\text{S}}$	Flash mode softstart time			100		$\mu\text{s}$
<b>Current Sink</b>						
ID	Total Output Current, Movie/Torch Mode	ENM = HIGH, RSETM = 90.7k $\Omega$ , D1+D2, $T_{\text{A}} = 25^{\circ}\text{C}$	133.5	150	166.5	mA
	Total Output Current, Flash Mode	ENF = HIGH, ENM = GND, RSETF = 9.07k $\Omega$ , D1+D2, $T_{\text{A}} = 25^{\circ}\text{C}$	1.305	1.5	1.695	A
	Output current matching <sup>5</sup>	75mA each channel, $T_{\text{A}} = 25^{\circ}\text{C}$				10
750mA each channel, $T_{\text{A}} = 25^{\circ}\text{C}$					10	%
$I_{\text{SHORT}}$	LED Short Checking Current			2.5		mA
<b>Control</b>						
$V_{\text{TH-L}}$	ENF, ENM pin logic low threshold				0.4	V
$V_{\text{TH-H}}$	ENF, ENM pin logic high threshold		1.4			V
$R_{\text{PD(ENF)}}$	ENF Internal Pull-down Resistance			300		k $\Omega$
$R_{\text{PD(ENM)}}$	ENM Internal Pull-down Resistance			300		k $\Omega$
$T_{\text{J-TH}}$	IC junction thermal shutdown threshold			150		$^{\circ}\text{C}$
	IC junction thermal shutdown hysteresis			20		$^{\circ}\text{C}$

4. The KTD267 is guaranteed to meet performance specifications over the  $-40^{\circ}\text{C}$  to  $+85^{\circ}\text{C}$  operating temperature range by design, characterization and correlation with statistical process controls.

5. The current matching between channels is defined as  $\frac{|I_{\text{D1}} - I_{\text{D2}}|}{(I_{\text{D1}} + I_{\text{D2}})}$ .

## Typical Characteristics

$V_{IN} = 3.6V$ ,  $I_{LED} = 100mA$ ,  $L = 1.0\mu H$ ,  $C_{in} = 2.2\mu F$ ,  $C_{out} = 2.2\mu F$ ,  $Temp = 25^{\circ}C$  unless otherwise specified.

Boost Converter Efficiency vs Input Voltage

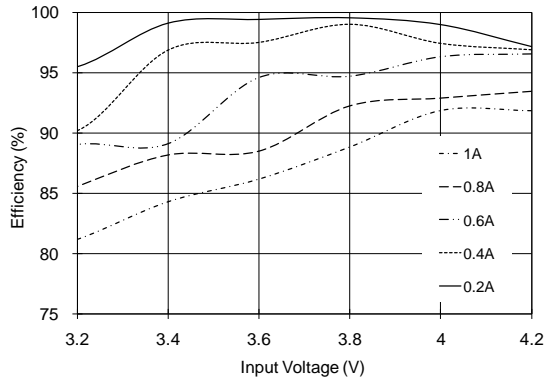

Operating Current (non-switching)

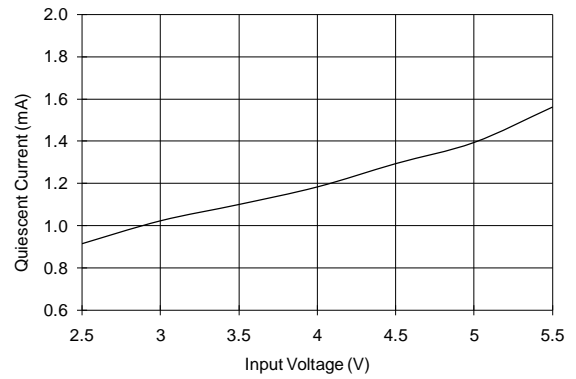

Line Regulation (Movie-mode)

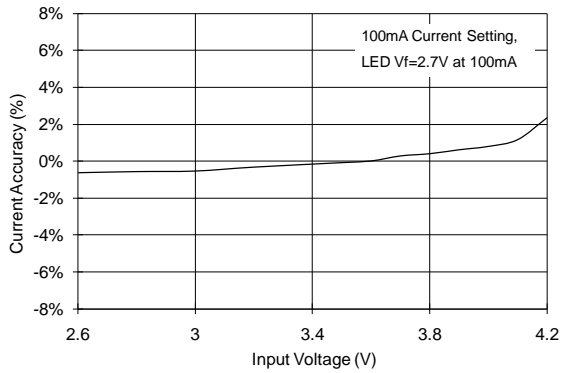

Switching Frequency vs. Input Voltage

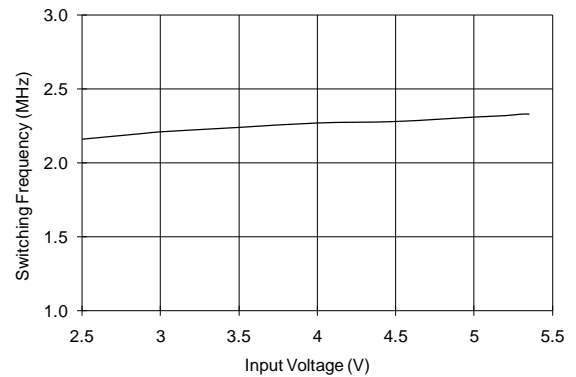

LED Current vs. Temperature (Movie-mode)

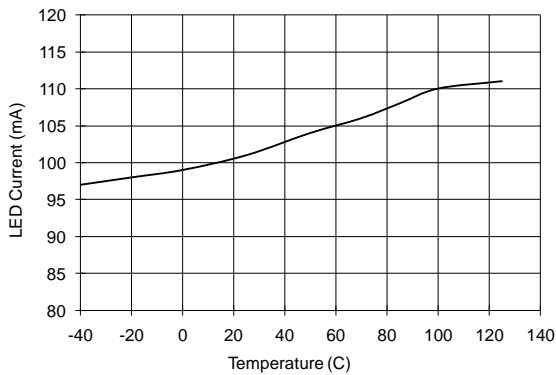

Operating Current vs. Temperature

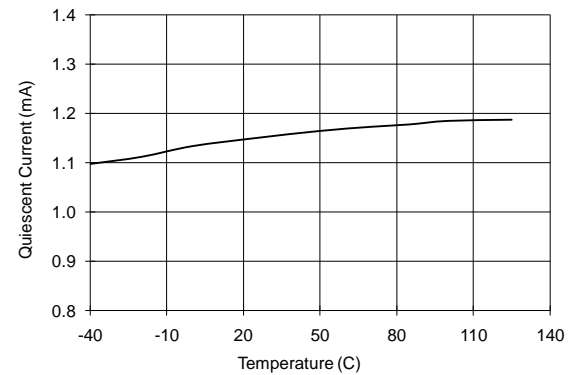

Typical Characteristics (continued)

1.5-Amp Flash Operation

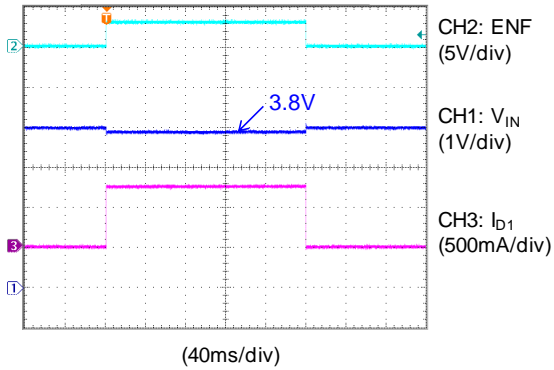

Soft Start: Flash Turn On ( $V_{in} = 4V$ , 0.75A/ch)

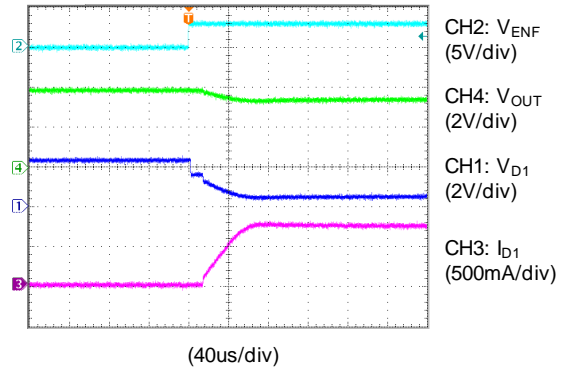

Movie-mode Turn On/Off ( $V_{in}=3.3V$ , 100mA/ch)

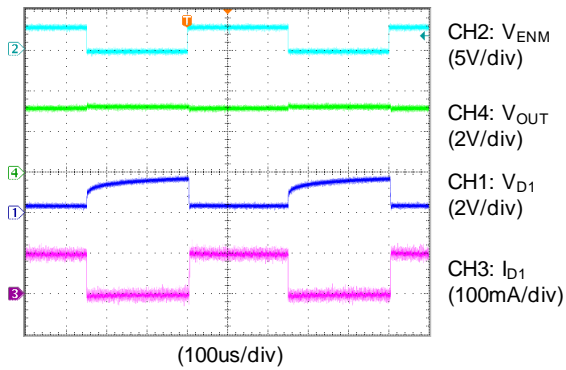

## Functional Block Diagram

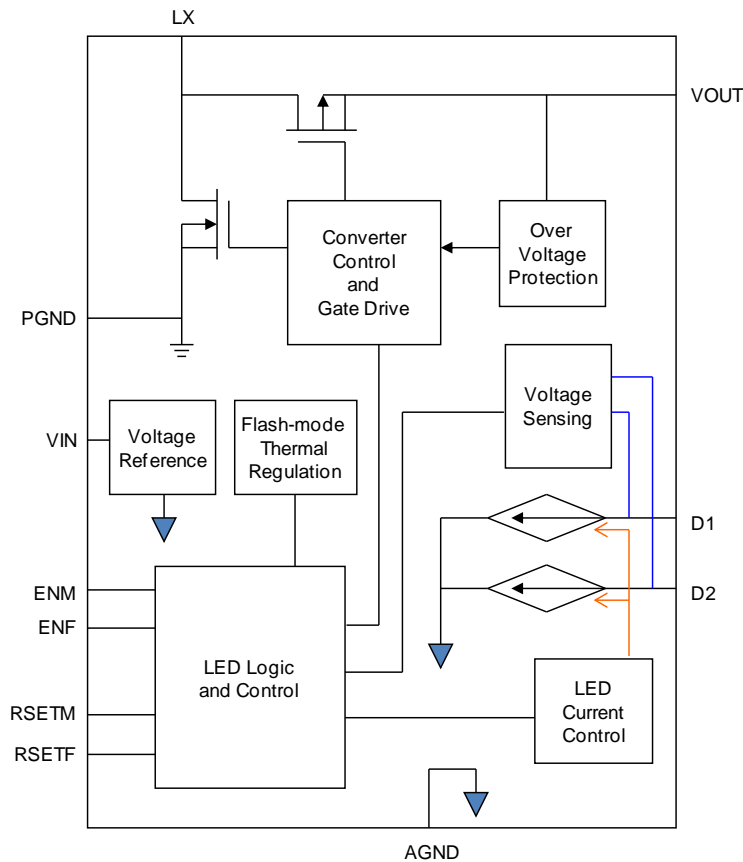

## Functional Description

The KTD267 is a very high switching frequency step-up (boost) flash LED driver. Two current regulating devices are integrated to drive up to 2 flash LEDs.

The voltage step-up is accomplished by a boost topology, using an inductor-based DC-DC switching converter, in which the inductor serves as an energy storage device. By integrating optimized power MOSFETs, the KTD267 internal switching frequency is 2.0MHz while still maintaining high power efficiency. Unlike a traditional DC-DC boost converter with a fixed output voltage, the KTD267 dynamically changes its output voltage depending on the flash LED forward voltage and current. The use of unique control schemes maintains accurate current regulation in each of the two current sinks while leaving the output voltage at a minimum, increasing the overall conversion efficiency. The internal step-up converter boosts the output voltage high enough to drive the LEDs with the highest forward voltage. The two current sinks can be shorted together to drive a higher current single flash LED, sinking up to 1.5A combined.

The control interface is designed for maximum design flexibility and compatibility with various types of system controls. When the ENF is pulled high while the ENM is low, the LED current will be ramped up to the flash-mode current level which is programmed by RSETF resistor. When ENM is pulled high while the ENF is low, the LED current will be ramped up to the movie/torch-mode current level which is programmed by RSETM resistor. However, if both ENM and ENF are high, the LED current will be set to movie/torch-mode current. The driver IC and the flash LEDs will be shutdown when both ENF and ENM are at logic low.

## Flash-Mode LED Current

D1 and D2 flash-mode LED current can be programmed up to a maximum total current of 1.5A or up to 0.75A per channel. The sink current in D1 and D2 are internally matched in the KTD267. The flash-mode current in each channel is set by the RSETF resistor. For the desired flash-mode current in each output, the resistor value can be calculated using the following equation:

$$I_{FLASH(D1)} = I_{FLASH(D2)} = 6800 / R_{RSETF}$$

A flash event is initiated by asserting the ENF pin while ENM is at logic low level. A flash event is automatically terminated when ENF is deasserted or when ENM is asserted.

Automatic thermal regulation control is active when KTD267 is in flash mode. If flash mode is enabled and the flash current is set to a high current value, the temperature of the IC can increase quickly. Once the IC's temperature goes above 100°C, the two sinks' currents will be automatically decreased according to the thermal regulation control loop. This can prevent the IC from triggering thermal shutdown and causing the LEDs to flicker. Depending on the thermal layout of the PCB and the flash mode current setting, the KTD267 sink current can be lower than the programmed value due to the thermal regulation protection feature.

## Movie/Torch-Mode LED Current

D1 and D2 movie/torch-mode LED current can be programmed up to a maximum total current of 400mA or up to 200mA per channel. Just as in flash mode operation, the output currents in D1 and D2 are internally matched. The movie/torch-mode current in each channel is set by the RSETM resistor. For the desired movie/torch-mode current in each output, the resistor value can be calculated using the following equation:

$$I_{MOVIE(D1)} = I_{MOVIE(D2)} = 6800 / R_{RSETM}$$

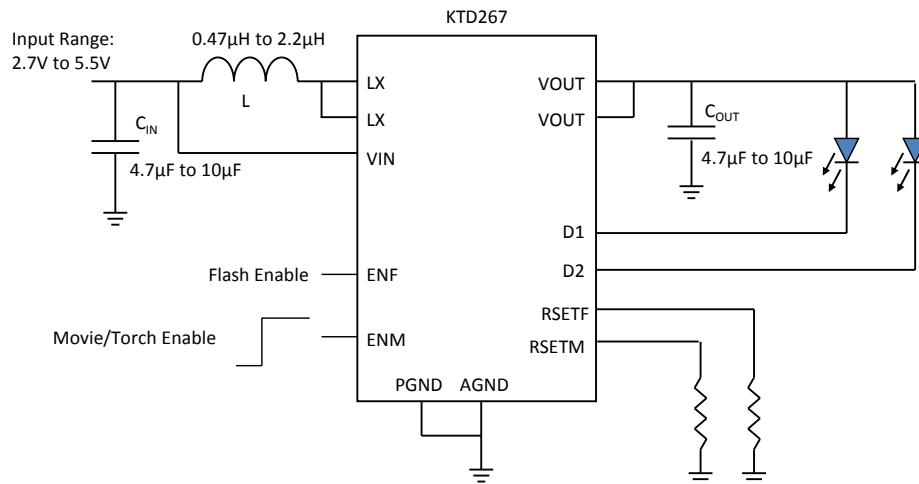

**Figure 1. Controlling Movie/Torch-mode with Simple Enable ON/OFF Pulse**

A movie/torch-mode event is initiated by asserting the ENM pin. For additional flexibility, a lower movie/torch-mode current than the value calculated above can be realized by applying a PWM dimming signal (see Figure 2) at ENM pin while ENF is held low. The average movie/torch-mode current will be proportional to the PWM duty ratio.



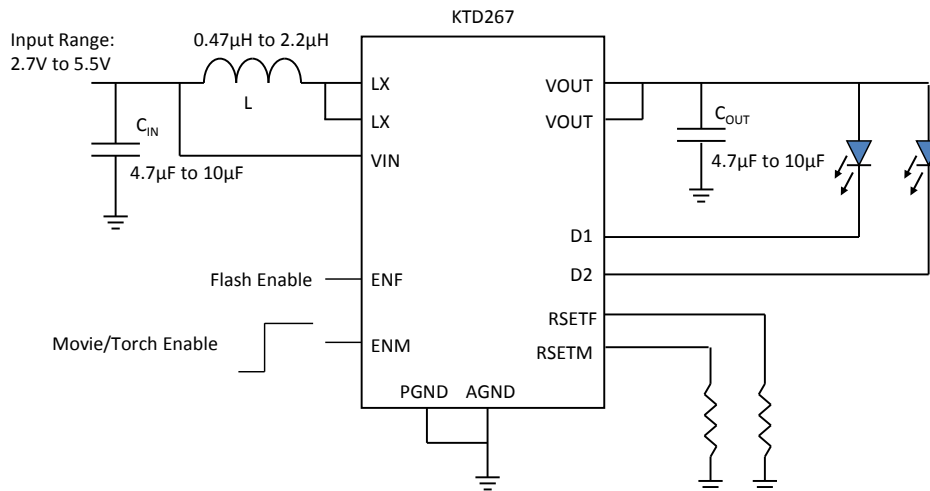

**Figure 2. Controlling Movie/Torch-mode with PWM Dimming Signal**

### LED Short Protection

When the KTD267 is enabled, there is a 2.5mA (typical) LED sensing current through each current sink. It is used to detect whether either LED is shorted by generating a voltage drop through each LED. The IC internally compares the voltage difference between  $V_{OUT}$  and each sink node (D1 and D2). If this difference is below a preset threshold, the IC will treat the respective LED as shorted and disable its Flash/Movie mode current through this LED channel. However, the 2.5mA sensing current will be kept to generate the LED's voltage drop. Because some normal flash LEDs may have larger than desired leakage current (up to hundreds of microamps) even it's not fully turned on, this 2.5mA sensing current can guarantee that a properly functioning LED will not mistakenly be treated as a shorted LED. If the short circuit is removed during operation, the channel will automatically recover to the programmed current setting.

### LED Open Protection

In case of LED open, the open channel will control the loop first so that  $V_{OUT}$  will reach OVP (approximately 5.3V), then KTD267 will automatically detect which channel's LED is open and disable that channel. From that point, the other channel with properly operating LED will control the loop and  $V_{OUT}$  will be regulated down to a normal operating voltage. This protection feature avoids unnecessary power consumption in the current sink by regulating the output voltage at the lowest level possible to maintain regulation for the active channel. Not only does this protect from open LEDs failures, but also allows only single flash LED operation with the unused channel floating or open. Open-circuit LED fault protection is reset when the IC is powered down and up again.

### Single/Dual LED Applications

Each of the sinks' (D1 and D2) current is regulated and matched for applications requiring two LEDs. For single LED applications, D1 and D2 can be connected together to drive one LED (see Figure 3). The current per sink follows the equations in Flash-Mode LED Current and Movie/Torch-Mode LED Current sections above.

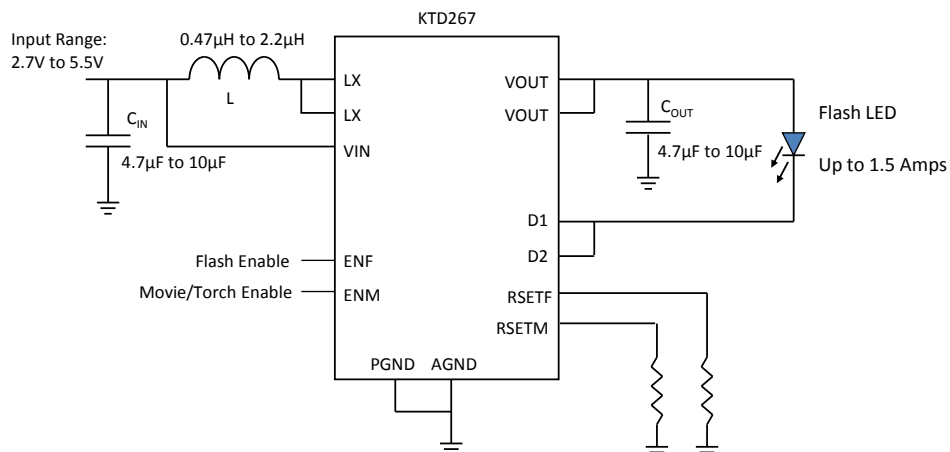

**Figure 3. Optional Single LED Configuration**

### Inductor Selection

The KTD267 is designed to use a 0.47µH to 2.2µH inductor. To prevent core saturation, ensure that the inductor-saturation current rating exceeds the peak inductor current for the application. The worst-case peak inductor current can be calculated with the following formula:

$$I_{Peak(L)} = \frac{V_{O(MAX)} \times I_{LED(MAX)}}{0.8 \times V_{IN(MIN)}} + \frac{V_{IN(MIN)} \times t_{ON(MAX)}}{2 \times L}$$

where 0.8 is the estimated efficiency of 80%.

For example, for a 1.5A total (or 0.75A per channel) LED current, the peak inductor current for a 1.0µH inductor could be as high as (estimated 50% as the maximum duty ratio at the minimum input voltage, maximum LED forward voltage, and maximum load current conditions):

$$I_{Peak(L)} = \frac{4V \times 1.5A}{0.8 \times 3.5V} + \frac{3.5V \times 0.25}{2 \times 1} = 2.58A$$

If the inductor value is smaller, the inductor peak current will increase. To maintain stable operations for the boost converter, the inductor peak current must be less than both the KTD267 current limit threshold and the inductor saturation current rating. Manufacturer's specifications of inductors list both the inductor DC current rating, which is a thermal limitation, and peak inductor current rating, which is determined by the saturation characteristics. Measurements at full load and high ambient temperature should be performed to ensure that the inductor does not saturate or overheat due to its parasitic resistance. Bench measurements are recommended to confirm actual inductor peak current  $I_{PEAK}$  and to ensure that the inductor does not saturate at maximum LED current and minimum input supply voltage.

If high efficiency is a critical requirement, a low DCR inductor should be selected.

**Table 1. Recommended Inductor**

Application	Inductor Part Number	Value (µH)	DCR (mΩ)	Saturation Current (A)	Dimensions (mm)	Manufacturer
2 LEDs at 0.75A each	LPS4018-102ML	1.0	42 max	3.8	4x4x1.8	Coilcraft

## Capacitor Selection

For good filtering, X5R or X7R low ESR ceramic capacitors are required.

A 4.7 $\mu$ F minimum input capacitor is recommended for high current flash LEDs to improve transient behavior of the regulator and EMI behavior of the total power supply circuit. The input capacitor should be placed as close as possible to the input pin and the PGND pin of the KTD267.

The output capacitance required depends on the required LED current. A 4.7 $\mu$ F to 10 $\mu$ F ceramic capacitor works well in most situations.

## PC Board Layout

Due to the fast switching transitions and high-current paths, careful PC board layout is required. Connect AGND pin directly to the exposed paddle underneath the IC; connect the exposed paddle to the PCB ground plane. The output bypass capacitor should be placed as close to the IC as possible. Minimize trace lengths between the IC and the inductor, the input capacitor, and the output capacitor; keep these traces short, direct, and wide. The ground connections of CIN and COUT should be as close together as possible and connected to PGND.

The RSETF and RSETM resistor ground terminals should be Kelvin connected to the KTD267 AGND using a separate trace in order to be isolated from any switching noise present on the PCB ground plane, as shown on Figure 4.

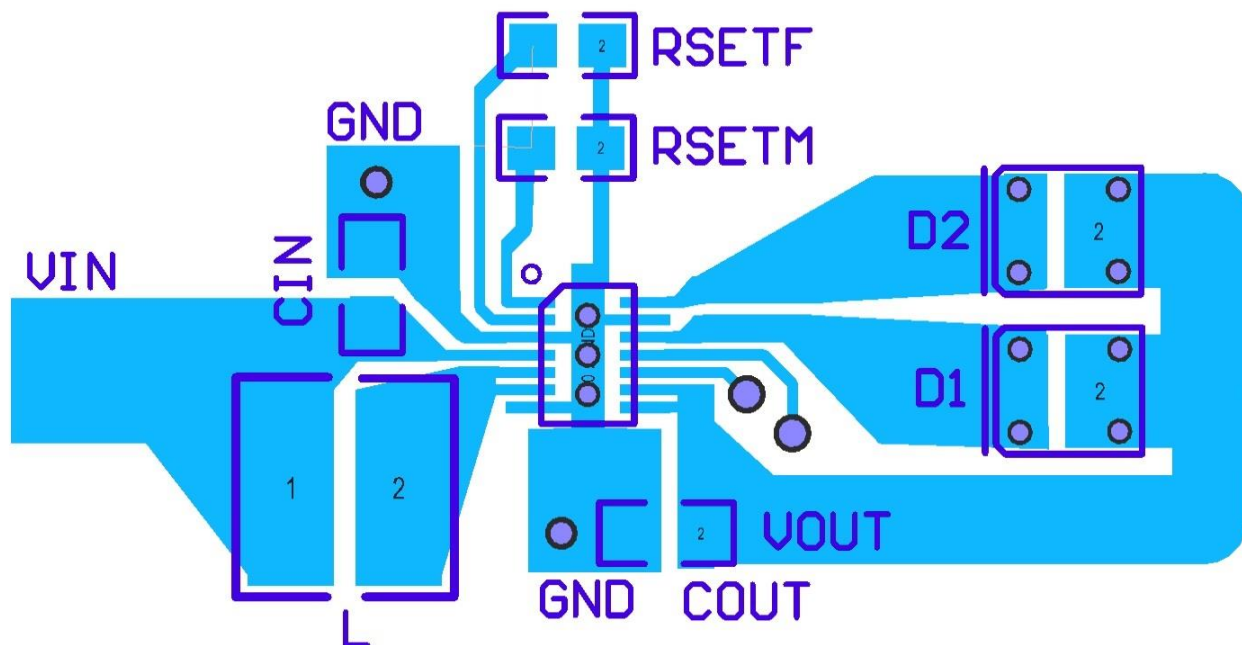
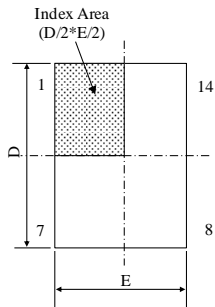

Figure 4. Recommended PCB layout

**Packaging Information**

**TDFN23-14**

**TOP VIEW**



**BOTTOM VIEW**

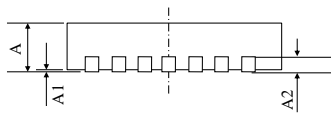
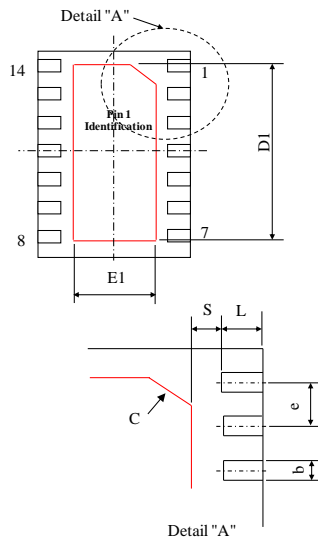

**Side VIEW**

Dimension	mm		
	Min.	Typ.	Max.
A	0.70	0.75	0.85
A1	0.00	0.05	0.10
A2	0.18	0.23	0.28
b	0.14	0.21	0.28
c	0.35 REF		
D	2.90	3.00	3.10
D1	2.35	2.50	2.65
E	1.90	2.00	2.10
E1	0.70	0.80	0.90
e	0.40BSC		
L	0.30	0.35	0.40
S	0.125 MIN		

**TDFN23-14 Recommended PCB Landing Pattern – Top View**

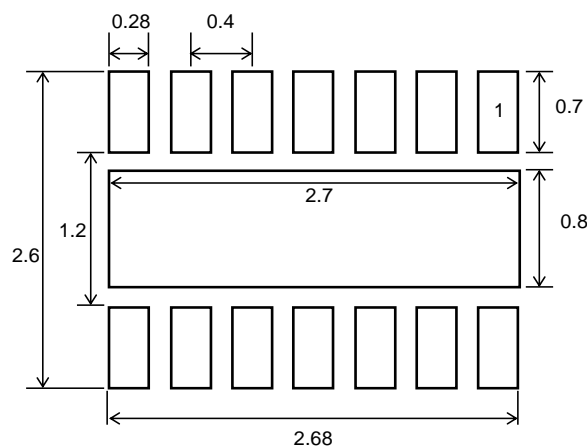

\*Dimensions are in millimeters

Kinetic Technologies cannot assume responsibility for use of any circuitry other than circuitry entirely embodied in a Kinetic Technologies product. No intellectual property or circuit patent licenses are implied. Kinetic Technologies reserves the right to change the circuitry and specifications without notice at any time.

# Mouser Electronics

Authorized Distributor

Click to View Pricing, Inventory, Delivery & Lifecycle Information:

[Kinetic Technologies:](#)

[KTD267EJH-TR](#)