

# M85049/49 and MS27506 Strain Reliefs



## Glenair Connector Designator F

MIL-C-38999 Series I & II,  
40M38277, PAN 6433-1,  
PATT 614, PATT 616,  
NFC93422 Series HE308 &  
HE309

**M85049/49-2 S 10 W**

Basic Part No.

S = Self-Locking  
Use Dash for  
Non-Self-Locking

Shell Size

Material and Finish Designator

A = Aluminum, Black Anodize (Non-Self-Locking Only)  
N = Aluminum, Electroless Nickel  
S = 300 Series Steel, Passivated (Self-Locking Only)  
W = Aluminum, 500 Hr. Cadmium Olive Drab  
Over Electroless Nickel

**MS27506 B 10-2**

**SUPERCEDED SPEC.**

Basic Part No.  
(Non-Self-Locking)

Material and Finish Designator  
B = Aluminum, 500 Hour Cadmium  
Olive Drab Over Electroless Nickel  
F = Aluminum, Electroless Nickel

Dash No.

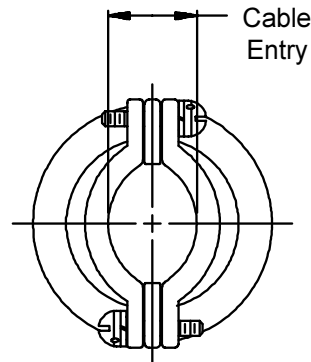
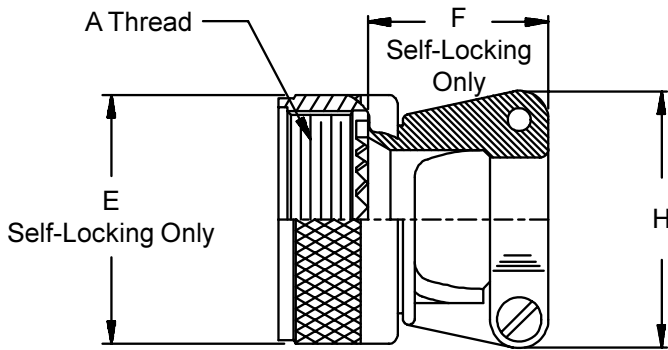

Note: Screw orientation shown is for non-self-locking configuration. Screws on self-locking configurations are on the same side/face of the clamp.

**TABLE I**

Dash No.	Shell Size Ref.	A Thread Class 2B	E Dia Max		H Max	Cable Entry	
			Self-Locking Only	Self-Locking Only		Min	Max
8	8/9	.438 - 28 UNEF	.86 (21.8)	.91 (23.1)	.85 (21.6)	.098 (2.5)	.234 (5.9)
10	10/11	.562 - 24 UNEF	.98 (24.9)	.91 (23.1)	.90 (22.9)	.153 (3.9)	.234 (5.9)
12	12/13	.688 - 24 UNEF	1.16 (29.5)	1.01 (25.7)	1.10 (27.9)	.190 (4.8)	.328 (8.3)
14	14/15	.813 - 20 UNEF	1.28 (32.5)	1.06 (26.9)	1.15 (29.2)	.260 (6.6)	.457 (11.6)
16	16/17	.938 - 20 UNEF	1.41 (35.8)	1.16 (29.5)	1.30 (33.0)	.283 (7.2)	.634 (16.1)
18	18/19	1.063 - 18 UNEF	1.52 (38.6)	1.41 (35.8)	1.50 (38.1)	.325 (8.3)	.614 (15.6)
20	20/21	1.188 - 18 UNEF	1.64 (41.7)	1.51 (38.4)	1.60 (40.6)	.343 (8.7)	.698 (17.7)
22	22/23	1.313 - 18 UNEF	1.77 (45.0)	1.66 (42.2)	1.70 (43.2)	.381 (9.7)	.823 (20.9)
24	24/25	1.438 - 18 UNEF	1.89 (48.0)	1.76 (44.7)	1.80 (45.7)	.418 (10.6)	.853 (21.7)

1. For complete dimensions see applicable Military Specification.
2. Metric dimensions (mm) are indicated in parentheses.
3. Cable Entry is defined as the accomodation entry for the wire bundle or cable. Dimensions are not intended for inspection criteria.