

Subminiature Coaxial Switch 0.85mm High, DC to 11GHz

MS-180 Series



Features

1. Performs over a wide frequency range

Applicable frequencies range over a wide bandwidth, from DC to 11GHz.

2. Low insertion loss

0.1 dB Max. up to 3GHz (not mated with the probe).
0.2 dB Max. up to 6GHz (not mated with the probe).
0.3 dB Max. up to 11GHz (not mated with the probe).

3. Space-saving and low profile design

0.85mm high above the board.
1.8mm x 1.8mm board space occupation.

4. Minimized Keep Out area and inspection port on chassis

Thanks to thinner probing tip in 2.24mm outer diameter, customer are able to achieve better space saving design.

5. Automatic board placement

Packaged on tape-and-reel the receptacles can be placed with vacuum nozzles of the automatic placement equipment.

6. Beryllium Free, Halogen Free

Chlorine, and Bromine are not used in the receptacles.
*Definition according to IEC 61249-2-21.
Br 900 ppm max., Cl 900 ppm max., and Br + Cl 1500 ppm max.

Overview

MS-180 series is the subminiature coaxial connectors with switch, developed for inspecting the RF module functionality and high frequency circuits. It can be used to mount on high density board of miniaturized devices and multiband frequency. It supports high frequency bands up to 11GHz. Enable secure and easy inspection of circuits. Verification of the circuit performance is accomplished by simply inserting the external plug in the board mounted receptacle. This action re-directs the circuit from normal condition to the plug side. Removing the plug restores circuit to its normal condition. Plug side is smaller than the previous model and occupies less space in customer's design.

Space saving design

0.85mm above the board
1.8 × 1.8mm on the board

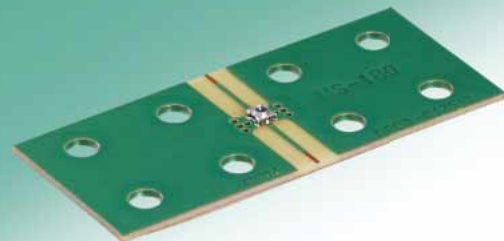

●PCB occupation

MS-156C

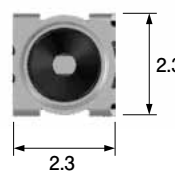

MS-180

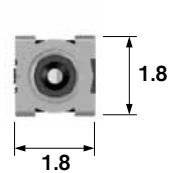

38.7% smaller

●Height



37% lower

●Weight

0.016g



0.007g

56.3% lighter

Product Specifications

	Not mated with the probe	Mated with the probe (MS-180-HRMJ-3)
Frequency range	DC to 11GHz	DC to 8GHz
V.S.W.R.	1.2 max. (DC to 3.0GHz)	1.2 max. (DC to 3.0GHz)
	1.3 max. (3.0GHz to 6.0GHz)	1.3 max. (3.0 to 8.0GHz)
	1.4 max. (6.0GHz to 11.0GHz)	
Insertion loss	0.1dB max. (DC to 3.0GHz)	0.3dB max. (DC to 3.0GHz)
	0.2dB max. (3.0GHz to 6.0GHz)	0.5dB max. (3.0GHz to 6.0GHz)
	0.3dB max. (6.0GHz to 11.0GHz)	0.6dB max. (6.0GHz to 8.0GHz)
Isolation	25dB min. (DC to 3.0GHz)	
	20dB min. (3.0GHz to 6.0GHz)	
	12dB min. (6.0GHz to 11.0GHz)	
Operating temperature range	-40°C to +85°C	
Rated power	2W	

Item	Specification	Conditions
1. Contact resistance	100mΩ max.	100mA max.
2. Insulation resistance	1000MΩ min.	100V DC
3. Withstanding voltage	No flashover or insulation breakdown	100V AC / 1 minute
4. Vibration	No electrical discontinuity of 1μs or more	Frequency : 10 to 55Hz, single amplitude of 0.75mm, 10 cycles in each of the 3 axis
5. Shock	No electrical discontinuity of 1μs or more	Acceleration of 490m/s ² , 11ms duration, sine halfwave, 3 cycles in each of the 3 axis, 18 times in total.
6. Temperature cycle	Contact resistance : 100mΩ max. Insulation resistance : 10MΩ min.	Temperature : -55°C → +15°C to +35°C → +85°C → +15°C to +35°C Time : 30 → 2 to 3 → 30 → 2 to 3 minutes 100 cycles
7. High temperature exposure	Contact resistance : 100mΩ max. Insulation resistance : 10MΩ min.	96 hours at 85°C
8. Low temperature exposure	Contact resistance : 100mΩ max. Insulation resistance : 10MΩ min.	96 hours at -55°C
9. Humidity (Steady state)	Contact resistance : 100mΩ max. Insulation resistance : 10MΩ min.	96 hours at 40±2°C and humidity of 90 to 95%
10. Durability	Contact resistance : 100mΩ max.	100 cycles

Materials / Finish

Part	Material	Finish	Remarks
Shell	Brass	Partially gold plated	—
Insulator	LCP	—	UL94V-0
C CONTACT	Copper alloy	Partially gold plated	—
A CONTACT	Copper alloy	Partially gold plated	—

◆ Typical Data

● NORMALLY CLOSED(Not Mated with the probe)

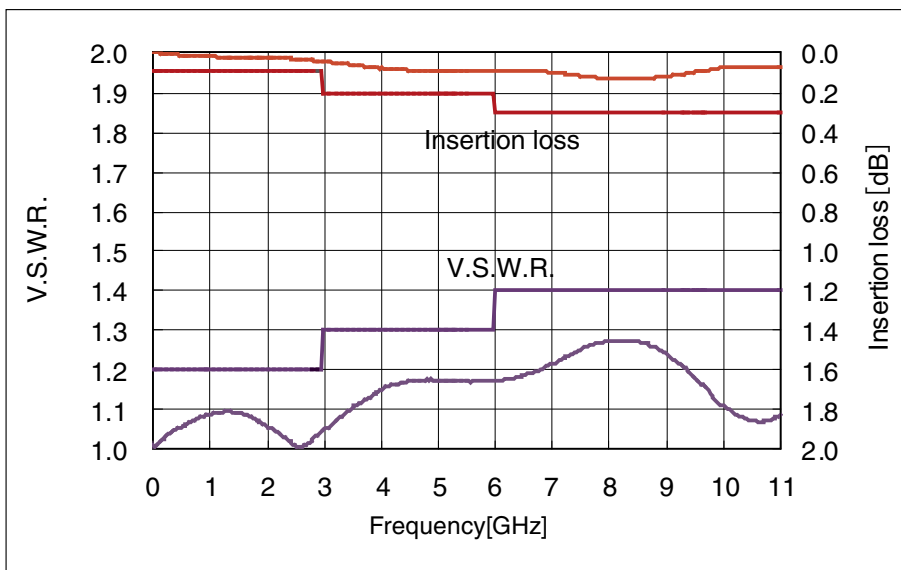

● NORMALLY OPEN(Mated with the probe)

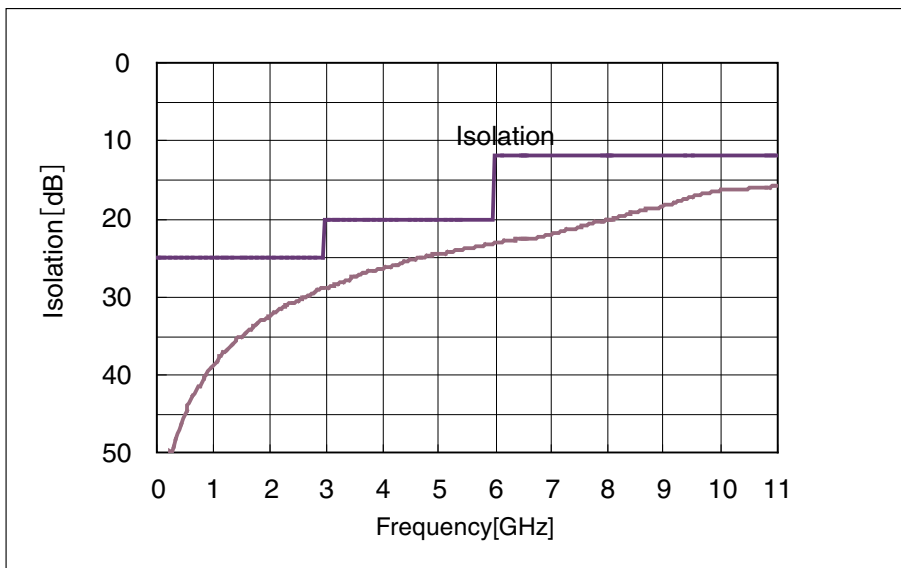
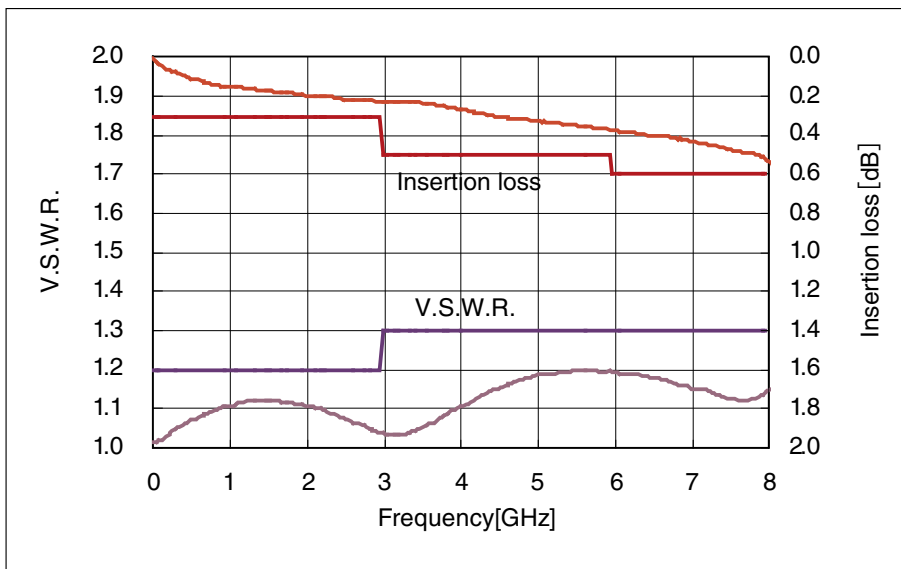

■ Receptacle

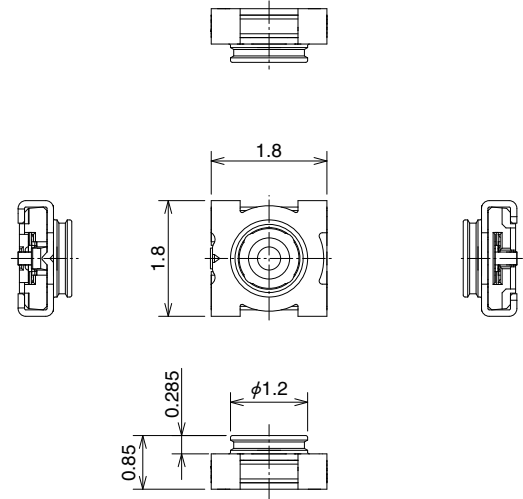

Part No.	HRS No.	Packaging
MS-180	358-0265-7	15,000 pcs/reel
MS-180(20)	358-0265-7 20	3,000 pcs/reel

■ Circuit diagram

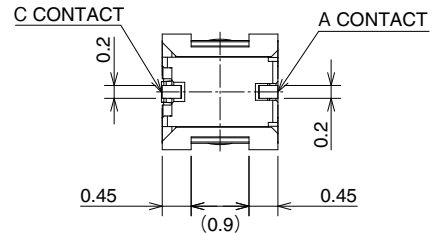
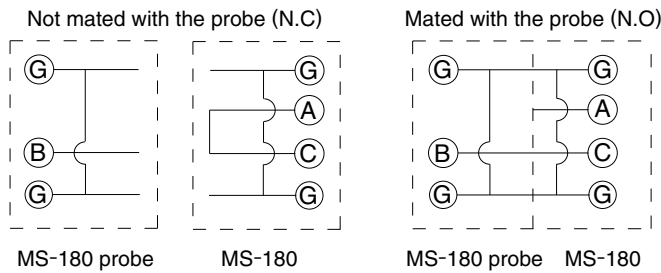

◆ PCB Footprint and Metal Stencil mask Dimensions

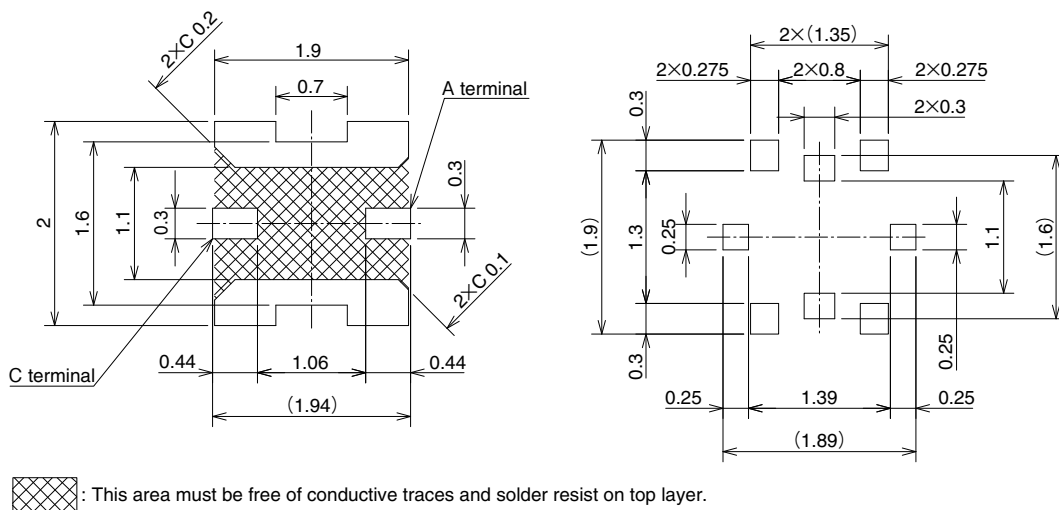

Note. · Do not reflow the product other than using specified PCB footprint and metal stencil dimensions. Otherwise it may cause solder and/or flux wicking affecting the product performance.
 · Do not use hand soldering for mounting of MS-180, since it could result in solder and flux wicking to the contact areas.

◆ Recommended Temperature Profile

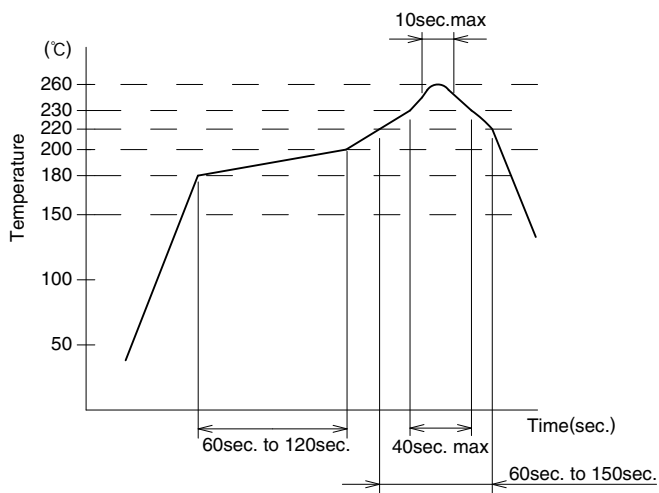

Using Lead-free Solder paste

① Maximum temperature	: 260°C
② Peak temperature time	: 10 sec. max.
③ 230°C min.	: 40 sec. max.
④ 220°C min.	: 60 sec. to 150 sec.
⑤ 180°C to 200°C	: 60 sec. to 120 sec.

Metal mask thickness : 0.1 mm
 Reflow cycles : 2 cycles

◆ Packaging Specifications

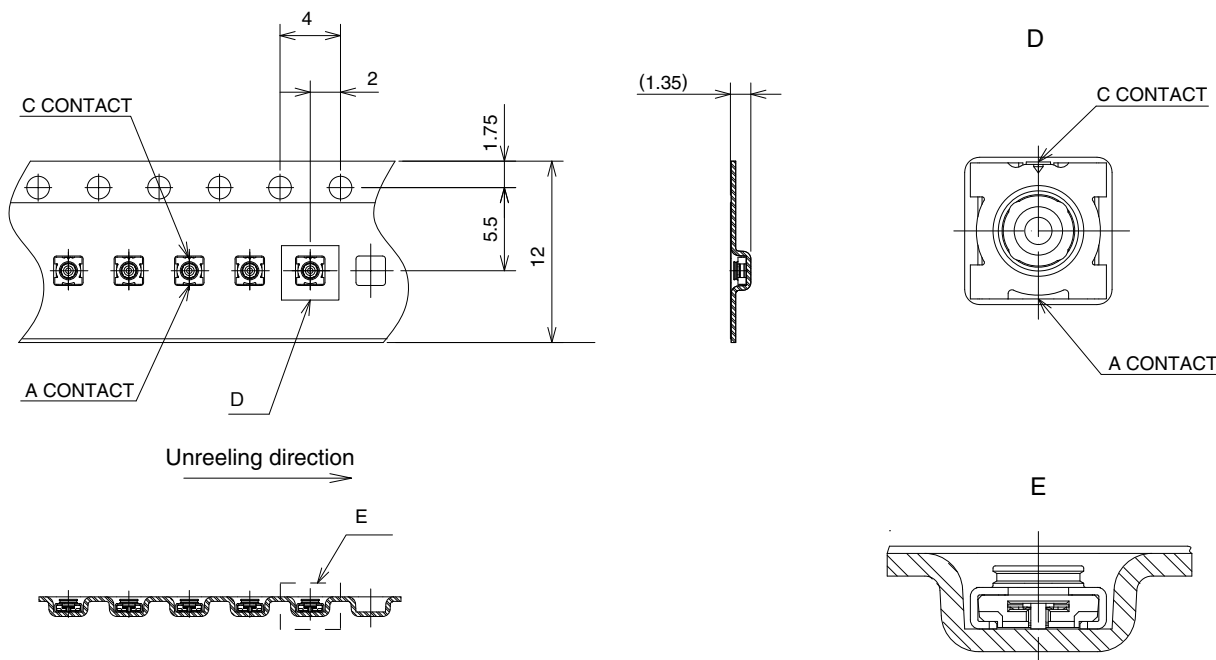

Reel dimentions

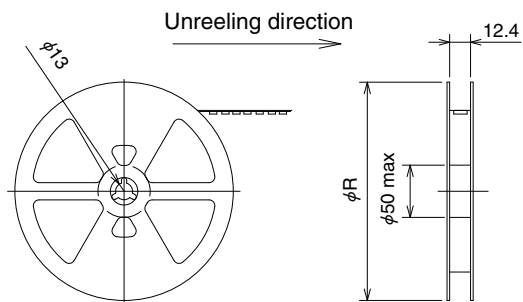

Part No.	Reel size	Packaging
MS-180	φ380mm	15,000 pcs/reel
MS-180(20)	φ180mm	3,000 pcs/reel

■ Measurement probe

● Fixed probing tip (for mass production lines) SMA connection

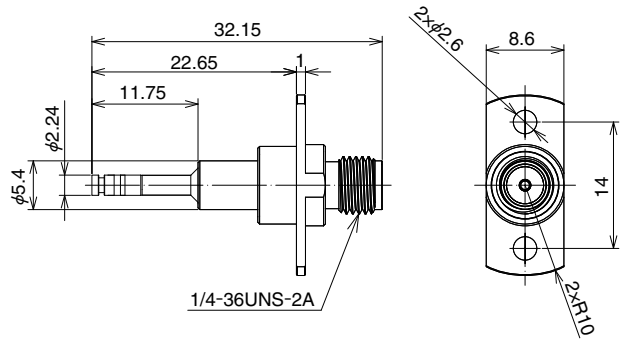

- Mating MS-180 vertically with 6 to 8N.
- This durability only applies to this specific probe.
- Proving jig need to equipped with floating capability and spring feature.

Part No.	HRS No.	Durability
MS-180-HRMJ-3	358-0318-1	10,000 cycles

● Fixed flange with floated probing tip (for mass production lines) SMA connection

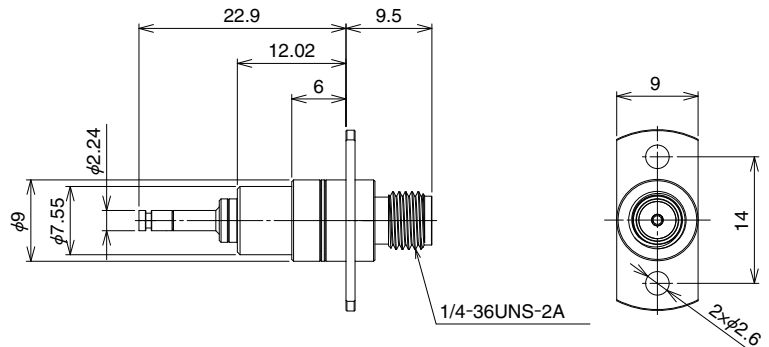

- The probe should mate vertically with the receptacle.
- Always use the probe within the specified stroke length.
- This durability only applies to this specific probe.

Part No.	HRS No.	Durability
MS-180-HRMJ-F6	358-0346-7	10,000 cycles

● Probe with simple lock (for lab use)

MS-180-040LP-H3



• This probe has simple lock mechanism to keep the probe connect with the receptacle without foreign assistance.

However the following must be ensured : the probe must be vertical to the receptacle / the cable on the probe cannot be pulled.

- This durability only applies to this specific probe.
- This product is sold as a complete assembly (probe with cable) ; please make your selection from the product shown on the right. Customization is available for cable lengths and the connection to the measurement equipment side. please contact your local Hirose Sales Representative.

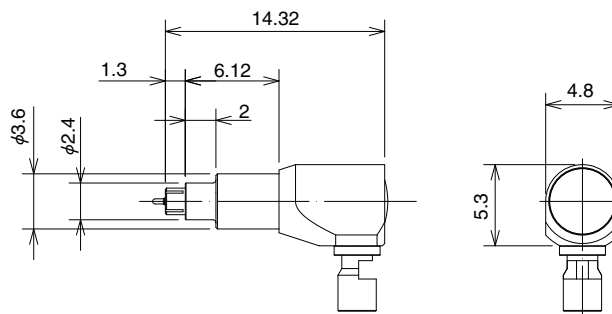

Part No.	HRS No.	Durability
MS-180-040LP-H3	358-0319-4	500 cycles

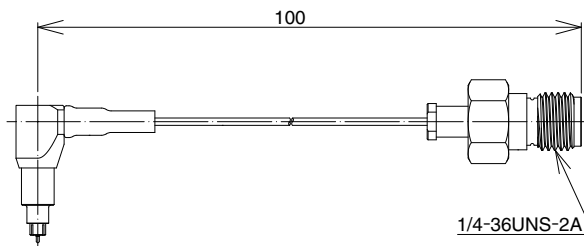

Part No.	HRS No.	Durability
MS180LH3-HRMJ-040V100	362-0224-9 01	500 cycles

● Probe with complete Lock (for lab use)

MS-180-088LP-H1



• This probe has locking feature to stay engaged with MS-180 once it is mated. it has to be vertical to maintain the engagement.

- This durability only applies to this specific probe.
- This product is sold as a complete assembly (probe with cable) ; please make your selection from the product shown on the right. Customization is available for cable lengths and the connection to the measurement equipment side. please contact your local Hirose Sales Representative.

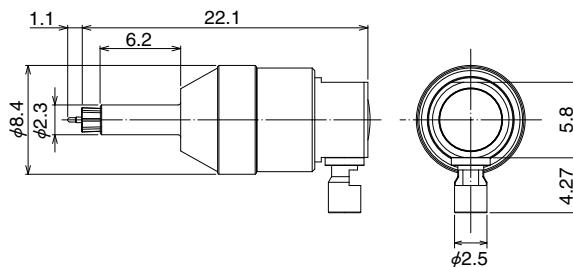

Part No.	HRS No.	Durability
MS-180-088LP-H1	358-0269-8	500 cycles

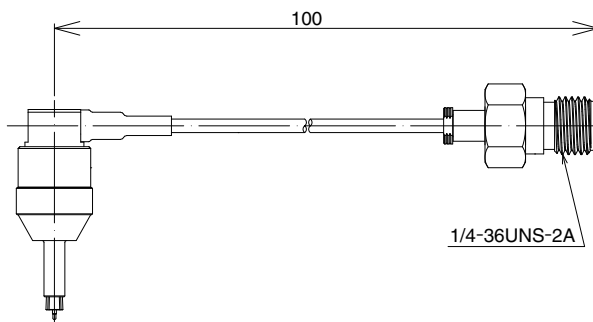

Part No.	HRS No.	Durability
MS180LH1-HRMJ-088V100	362-0223-6 01	500 cycles

■ SMA conversion adapter for probe



- For measurement RF Performance of MS-180 probe.
- For electrical calibration at probe mating face.

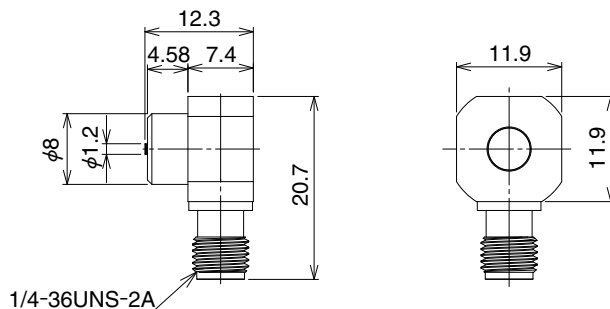

Part No.	HRS No.	Durability
MS-180LR-HRMJ-1	358-0304-7	500 cycles

◆ Precautions

1. Do not use the washing process.
2. This product is intended to be used for circuit inspection only. Consult us if any other application is considered.
3. Do not use lab use probe for mass production line.
4. Do not use hand soldering for mounting of MS-180, since it could result in solder and flux wicking to the contact areas.
5. When using a heat gun, hot plate, or similar methods for mounting receptacle on PCB, limit the temperature to 260°C apply for 10 seconds max.
6. Do not reflow the product other than using specified PCB footprint and metal stencil dimensions. Otherwise it may cause solder and/or flux wicking affecting the product performance.
7. Avoid using the product in dusty, mixed gases and any other environment which is outside of the specified range in spec sheet.
8. Do not allow any particles to enter the board mounted receptacle when cutting PCB.



HIROSE ELECTRIC CO.,LTD.

2-6-3,Nakagawa Chuoh,Tsuzuki-Ku,Yokohama-Shi 224-8540,JAPAN
 TEL: +81-45-620-3526 Fax: +81-45-591-3726
<http://www.hirose.com>
<http://www.hirose-connectors.com>