

AXL E IOL DI8 M12 6P - Digital module



2702658

<https://www.phoenixcontact.com/us/products/2702658>

Please be informed that the data shown in this PDF document is generated from our online catalog. Please find the complete data in the user documentation. Our general terms of use for downloads are valid.



Axioline E digital input device via IO-Link in plastic housing with one IO-Link A-port and eight inputs, 24 V DC, 4-conductor technology, M12 connectors

Product description

The Axioline E digital input device is connected to an IO-Link master via an IO-Link A port. It is used to acquire digital signals via IO-Link. Use within different networks is possible via the IO-Link master.

Your advantages

- Connection to an IO-Link master with M12 connector (A-coded, 4-pos.)
- Type A port
- IO-Link specification V1.1.2
- Connection of up to 8 inputs with M12 connectors (A-coded, 5-pos.)
- Diagnostic and status indicators
- Short-circuit and overload protection of the sensor supply
- Device rating plate stored
- IP65/IP67 degree of protection

Commercial data

Item number	2702658
Packing unit	1 pc
Minimum order quantity	1 pc
Sales key	DR04
Product key	DRI7DF
Catalog page	Page 180 (C-6-2019)
GTIN	4055626279671
Weight per piece (including packing)	297.7 g
Weight per piece (excluding packing)	297.7 g
Customs tariff number	85176200
Country of origin	DE

AXL E IOL DI8 M12 6P - Digital module



2702658

<https://www.phoenixcontact.com/us/products/2702658>

Technical data

Dimensions

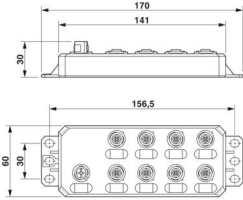
Dimensional drawing	
Width	60 mm
Height	141 mm
Depth	20 mm
Note on dimensions	The height is 170 mm including fixing clips. The depth is 30 mm including the connector.

Notes

Note on application	
Note on application	Only for industrial use
Utilization restriction	
EMC note	EMC: class A product, see manufacturer's declaration in the download area

Material specifications

Housing material	Pocan®
Color	anthracite grey RAL 7016

Input data

Digital:	
Input name	Digital inputs
Description of the input	EN 61131-2 types 1 and 3
Number of inputs	8
Cable length	max. 30 m (to the sensor)
Connection method	M12 connector
Connection technology	4-conductor
Input voltage range "0" signal	-3 V ... 5 V DC
Input voltage range "1" signal	11 V DC ... 30 V DC
Nominal input voltage U_{IN}	24 V DC
Nominal input current at U_{IN}	typ. 2.4 mA
Input filter time	1 ms
Protective circuit	Overload protection, short-circuit protection of sensor supply Polarity reversal protection of the inputs

AXL E IOL DI8 M12 6P - Digital module



2702658

<https://www.phoenixcontact.com/us/products/2702658>

IO-Link

Number of ports	1
Connection method	M12 connector, A-coded
Connection technology	3-conductor
Port type	Class A
Specification	V1.1.2
Reverse polarity protection	yes
Transmission speed	230.4 kbps (COM3)
Cycle Time	< 1 ms
Process data update	< 1 ms
Amount of process data	16 bit (Input data)

Product properties

Product type	I/O component
Product family	Axioline E
Type	Stand-Alone
Special properties	Plastic housing

Data management status

Article revision	02
------------------	----

Electrical properties

Supply: IO-Link

Designation	IO-Link port supply (L+)
Nominal voltage for I/O supply	24 V DC (Provided via the IO-Link interface of the IO-Link master.)
Supply voltage range	20 V DC ... 30 V DC (including all tolerances, including ripple)
Nominal current per device	approx. 40 mA (15 mA no load + current consumption sensors)
Permissible cable length	max. 20 m
Protective circuit	Reverse polarity protection; yes

Supply:

Designation	Power supply for sensors
Current consumption	max. 1.28 A (per port) max. 1.28 A (Device dependent; observe the current of the IO-Link master that is made available via L+.)

Electrical isolation/isolation of the voltage ranges

Test voltage: 24 V supply / functional ground	500 V AC, 50 Hz, 1 min.
---	-------------------------

Connection data

Connection method	M12 connector
Note on the connection method	in accordance with IEC 61076-2-101, M12 connection technology

Environmental and real-life conditions

AXL E IOL DI8 M12 6P - Digital module



2702658

<https://www.phoenixcontact.com/us/products/2702658>

Ambient conditions

Ambient temperature (operation)	-25 °C ... 60 °C
Degree of protection	IP65/IP67
Air pressure (operation)	70 kPa ... 106 kPa (up to 3000 m above sea level)
Air pressure (storage/transport)	70 kPa ... 106 kPa (up to 3000 m above sea level)
Ambient temperature (storage/transport)	-25 °C ... 70 °C
Permissible humidity (operation)	5 % ... 95 %
Permissible humidity (storage/transport)	5 % ... 95 %

Standards and regulations

Protection class	III (IEC 61140, EN 61140, VDE 0140-1)
------------------	---------------------------------------

Mounting

Mounting type	Wall mounting
---------------	---------------

AXL E IOL DI8 M12 6P - Digital module

2702658

<https://www.phoenixcontact.com/us/products/2702658>

Drawings

Connection diagram

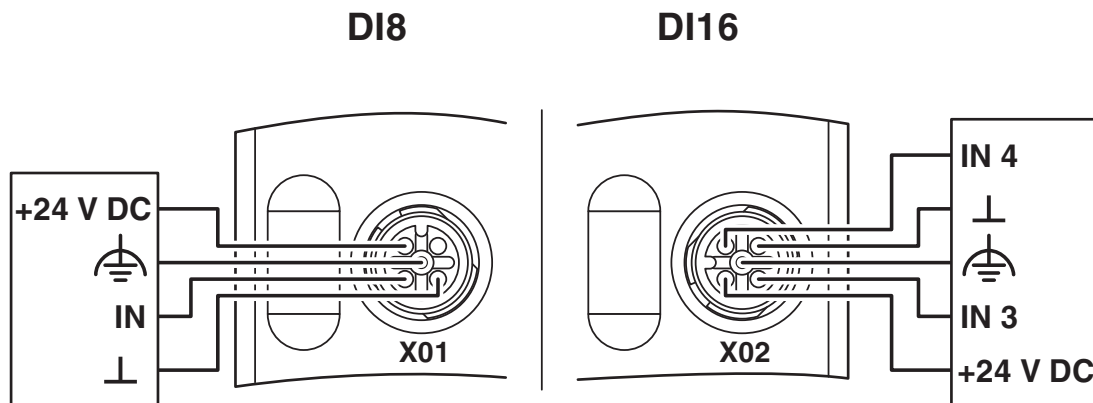

Dimensional drawing

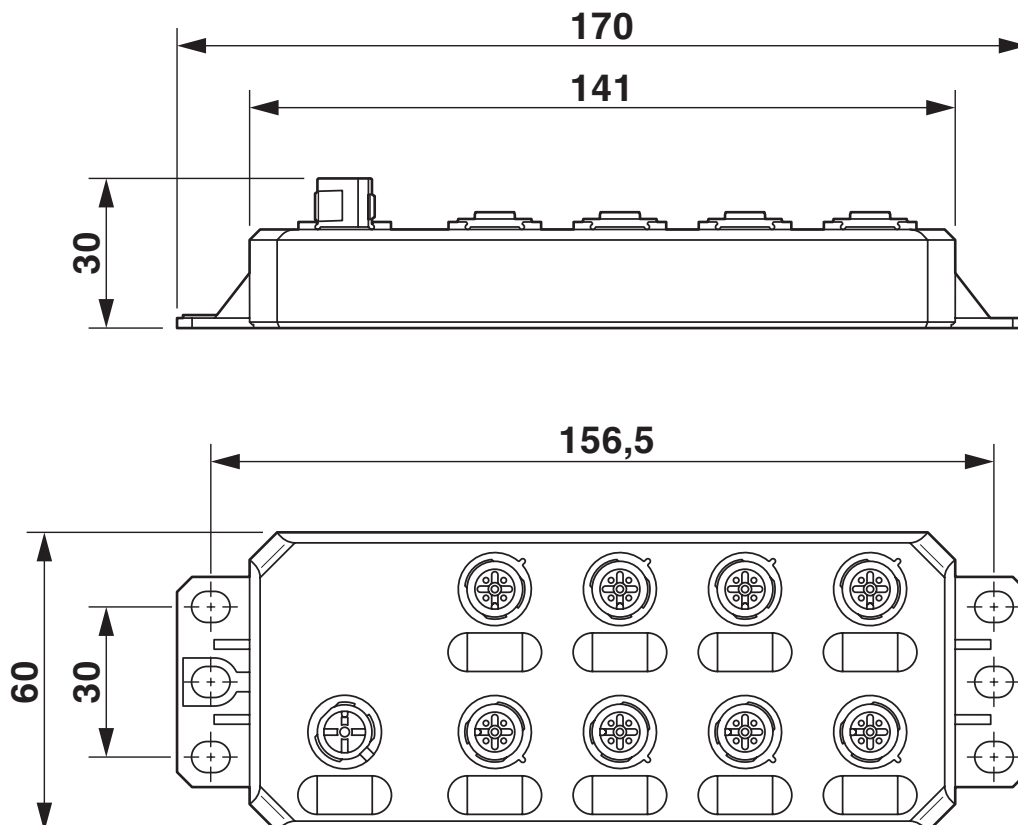

AXL E IOL DI8 M12 6P - Digital module





2702658

<https://www.phoenixcontact.com/us/products/2702658>

Approvals

To download certificates, visit the product detail page: <https://www.phoenixcontact.com/us/products/2702658>

 UL Listed Approval ID: E238705				
	Nominal voltage U_N	Nominal current I_N	Cross section AWG	Cross section mm^2
	125 V	1 A	-	-

 cUL Listed Approval ID: E238705				
	Nominal voltage U_N	Nominal current I_N	Cross section AWG	Cross section mm^2
	125 V	1 A	-	-

cULus Listed				
---------------------	--	--	--	--

AXL E IOL DI8 M12 6P - Digital module



2702658

<https://www.phoenixcontact.com/us/products/2702658>

Classifications

ECLASS

ECLASS-11.0	27242604
ECLASS-12.0	27242604
ECLASS-13.0	27242604

ETIM

ETIM 9.0	EC001599
----------	----------

UNSPSC

UNSPSC 21.0	32151600
-------------	----------

2702658

<https://www.phoenixcontact.com/us/products/2702658>

Environmental product compliance

EU RoHS

Fulfills EU RoHS substance requirements	Yes
Exemption	6(c), 7(a), 7(c)-I

China RoHS

Environment friendly use period (EFUP)	EFUP-50
	An article-related China RoHS declaration table can be found in the download area for the respective article under "Manufacturer declaration". For all articles with EFUP-E, no China RoHS declaration table issued and required.

EU REACH SVHC

REACH candidate substance (CAS No.)	Lead(CAS: 7439-92-1)
SCIP	1774c88d-f2d4-4bda-9c2d-3b3190a243a0

Phoenix Contact 2024 © - all rights reserved

<https://www.phoenixcontact.com>

Phoenix Contact USA
586 Fulling Mill Road
Middletown, PA 17057, United States
(+717) 944-1300
info@phoenixcon.com