

Melody sound source LSI for cellular phone

BU8709KN

● Description

BU8709KN is a melody sound source LSI for cellular phones. This LSI generates 64 high quality polyphonic tones through high sampling rate ($f_s=44.1\text{kHz}$).

1 ADPCM encoder and 2 ADPCM decoders functions are embedded, providing mixing capabilities. It can customize output sounds by an equalizer function and display the signals by Graphic Equalizer. It also has Reverb function, as well as LED & Vib synchronization.

● Features

- 1) Simultaneous generation of up to 64 polyphonic tones out of a tone palette of 222 sounds
- 2) High-quality tone reproduction using $F_s=44.1\text{kHz}$, two-voice method
- 3) 12bit pitch bending and modulation support
- 4) Stereo and monaural modes
- 5) Built-in equalizer (3 channels) and vibration function
- 6) Built-in LED (3 channels)
- 7) Built-in reverb function
- 8) Plays up to four songs simultaneously
- 9) Built-in ADPCM encoder (1 channel) and decoder (2 channel), enables mixing with melody
- 10) Select among μ -law, A-law, and linear input for encoder
- 11) Control from CPU using serial or parallel interface
- 12) Built-in FIFO for sound source and ADPCM to reduce CPU's processing load
- 13) Built-in graphic equalizer (7-band)
- 14) Supports digital output (standard format or IIS format)
- 15) Provides 1-Poly mode for low power consumption

● Applications

Sound source for cellular phones and portable appliances

● Absolute Maximum Ratings ($T_a=25^\circ\text{C}$)

Parameter	Symbol	Limits	Unit	Conditions
Max. I/O supply voltage	VDDIO	-0.3 ~ 4.5	V	DVDD_IO, AVDD
Max. CORE supply voltage	VDDCO	-0.3 ~ 3.5	V	DVDD_CORE
Voltage applied to pin	VIN	DVSS-0.3 ~ VDDIO+3.5	V	
Input current	IIN	-1 ~ +1	μA	
Power dissipation	Pd	500	mW	Warranty setting of single IC
Storage temperature range	Tstg	-50 ~ 125	$^\circ\text{C}$	
Operating temperature range	Topr	-30 ~ 85	$^\circ\text{C}$	

*Derating : 5.0mW/ $^\circ\text{C}$ for operation above $T_a=25^\circ\text{C}$

● Dimension (Unit : mm)

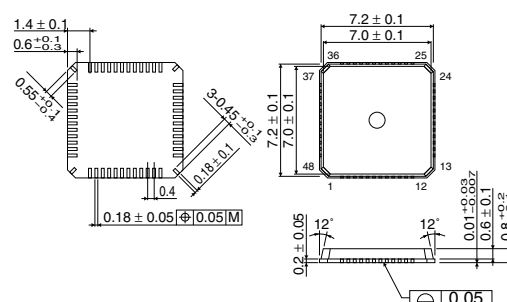

QFN48U

● Recommended Operating Conditions (Ta=25°C)

Parameter	Symbol	Min.	Typ.	Max.	Unit	Conditions
I/O power supply voltage	VDDIO	2.7	3.0	3.3	V	DVDD_IO, AVDD
CORE power supply voltage	VDDCO	2.25	2.5	2.75	V	DVDD_CORE
Ambient temperature	Ta	-30	25	85	°C	
MCLK input frequency	FMCLK	2.688	—	20	MHz	
SCLK input frequency	FSCLK	—	—	20	MHz	Scale precision is approximately 0.2%.
MCLK duty	DMCLK	40	50	60	%	
Analog pin's load resistance	ZAN	10	—	—	kΩ	After DC Coupling

● Electrical characteristics (Unless otherwise noted, Ta=25°C)

Parameter	Symbol	Min.	Typ.	Max.	Unit	Conditions
<Digital DC characteristics>						
High-level input voltage	VIH	DVDD_IO-0.5	—	—	V	
Low-level input voltage	VIL	—	—	DVSS+0.5	V	
High-level input current	IIH	—	—	1	μA	VIH=VDDIO
Low-level input current	IIL	-1	—	—	μA	VIL=DVSS
High-level output voltage	VOH	DVDD_IO-0.3	—	—	V	IOH=-0.8mA
Low-level output voltage	VOL	—	—	DVSS+0.3	V	IOH=0.8mA
<Analog DC characteristics>						
VREF pin voltage	VAGND	0.475AVDD	0.5AVDD	0.525AVDD	V	IOUT=0A (no load)
Analog pin voltage	VOUT	0.47AVDD	0.5AVDD	0.53AVDD	V	IOUT=0A (no load) Not playing
<General characteristics>						
VREF pin rise time	TRVR	—	15	25	mS	When CVREF=1μF, NRST=L→H
<Analog pin characteristics>						
Analog amplitude	VMAX	—	1.8	—	Vp-p	Theoretical value for dynamic range
Power consumption DVDD_CORE=2.5V, DVDD_IO=3.0V, AVDD=3.0V, internal operation frequency SYS_CLK=50MHz						
Analog Idd 1	AIDD1	—	1.5	2.5	mA	Playing
Digital Idd 10	DIDD10	—	28	35	mA	Not playing MIDI CLK control="101"
Digital Idd 11 (DVDD_CORE)	DIDD11	—	56	65	mA	Playing 64POLY
Digital Idd 12 (DVDD_IO)	DIDD12	—	0.4	1	mA	Playing
Analog Idd 2	AIDD2	—	—	1	μA	Standby mode
Digital Idd 20 (DVDD_CORE)	DIDD20	—	—	10	μA	Standby mode
Digital Idd 21 (DVDD_IO)	DIDD21	—	—	5	μA	Standby mode

● Block Diagram

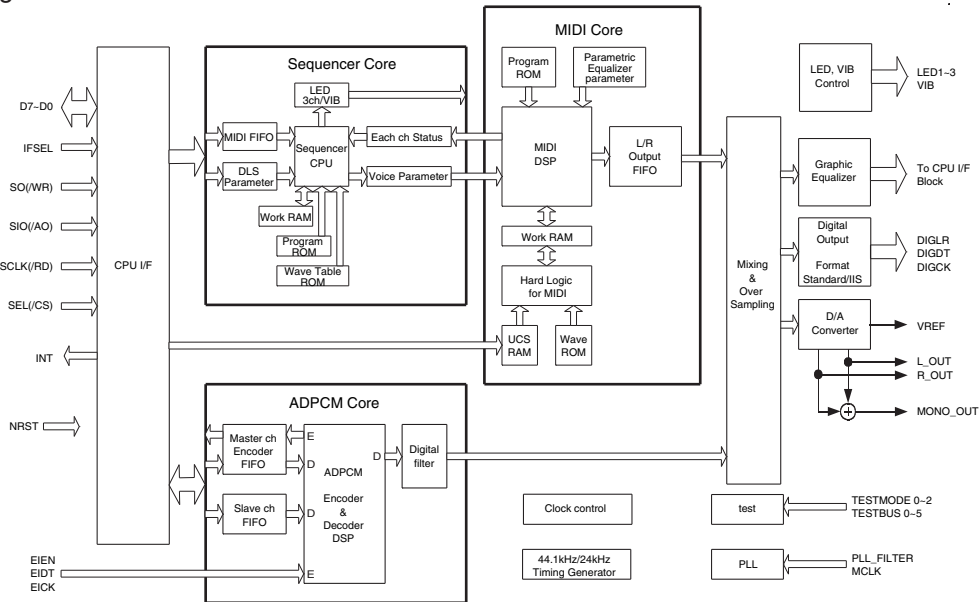

Notes

- No technical content pages of this document may be reproduced in any form or transmitted by any means without prior permission of ROHM CO.,LTD.
- The contents described herein are subject to change without notice. The specifications for the product described in this document are for reference only. Upon actual use, therefore, please request that specifications to be separately delivered.
- Application circuit diagrams and circuit constants contained herein are shown as examples of standard use and operation. Please pay careful attention to the peripheral conditions when designing circuits and deciding upon circuit constants in the set.
- Any data, including, but not limited to application circuit diagrams information, described herein are intended only as illustrations of such devices and not as the specifications for such devices. ROHM CO.,LTD. disclaims any warranty that any use of such devices shall be free from infringement of any third party's intellectual property rights or other proprietary rights, and further, assumes no liability of whatsoever nature in the event of any such infringement, or arising from or connected with or related to the use of such devices.
- Upon the sale of any such devices, other than for buyer's right to use such devices itself, resell or otherwise dispose of the same, no express or implied right or license to practice or commercially exploit any intellectual property rights or other proprietary rights owned or controlled by
- ROHM CO., LTD. is granted to any such buyer.
- Products listed in this document use silicon as a basic material.
Products listed in this document are no antiradiation design.

The products listed in this document are designed to be used with ordinary electronic equipment or devices (such as audio visual equipment, office-automation equipment, communications devices, electrical appliances and electronic toys).

Should you intend to use these products with equipment or devices which require an extremely high level of reliability and the malfunction of which would directly endanger human life (such as medical instruments, transportation equipment, aerospace machinery, nuclear-reactor controllers, fuel controllers and other safety devices), please be sure to consult with our sales representative in advance.

About Export Control Order in Japan

Products described herein are the objects of controlled goods in Annex 1 (Item 16) of Export Trade Control Order in Japan.

In case of export from Japan, please confirm if it applies to "objective" criteria or an "informed" (by MITI clause) on the basis of "catch all controls for Non-Proliferation of Weapons of Mass Destruction.