

FL SWITCH 1608 - Industrial Ethernet Switch



1196227

<https://www.phoenixcontact.com/us/products/1196227>

Please be informed that the data shown in this PDF document is generated from our online catalog. Please find the complete data in the user documentation. Our general terms of use for downloads are valid.



Unmanaged Switch 1000, 8 M12 ports 10/100 Mbps, degree of protection: IP65/IP66/IP67, Extended temperature range

Your advantages

- QoS-prioritized (Quality of Service) messages
- Local diagnostic indicators with LEDs
- Enhanced traffic prioritization for automation protocols
- PROFINET PTCP filter for reliable communication on PROFINET networks
- PROFINET Conformance Class A for real-time data exchange
- Auto negotiation and autocrossing detection simplifies installation and setup

Commercial data

Item number	1196227
Packing unit	1 pc
Minimum order quantity	1 pc
Sales key	DN19
Product key	DNN114
GTIN	4063151253677
Weight per piece (including packing)	1,400 g
Weight per piece (excluding packing)	1,400 g
Customs tariff number	85176200
Country of origin	DE

FL SWITCH 1608 - Industrial Ethernet Switch



1196227

<https://www.phoenixcontact.com/us/products/1196227>

Technical data

Dimensions

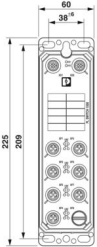
Dimensional drawing	
Width	60 mm
Height	226 mm
Depth	46 mm

Notes

Note on application

Note on application	Only for industrial use
---------------------	-------------------------

Material specifications

Housing material	Zinc die-cast
------------------	---------------

Mounting

Mounting type	Wall mounting
---------------	---------------

Interfaces

Ethernet

Connection method	M12 connectors, D-coded
Note on the connection method	Auto negotiation and autocrossing
Transmission speed	10/100 Mbps
Transmission physics	Copper
Transmission length	100 m (per segment)
Signal LEDs	Data receive, link status
No. of channels	8 (M12 ports)

Product properties

Product type	Switch
Product family	Unmanaged Switch 1000
Type	Stand-Alone
MTTF	79.2 Years (MIL-HDBK-217F standard, temperature 25°C, operating cycle 100%)
	845.5 Years (SN 29500 standard, temperature 25°C, operating cycle 21%)

FL SWITCH 1608 - Industrial Ethernet Switch



1196227

<https://www.phoenixcontact.com/us/products/1196227>

	610.2 Years (Telcordia standard, 25°C temperature, 21% operating cycle (5 days a week, 8 hours a day))
Special properties	Extended temperature range

Data management status

Article revision	01
------------------	----

Switch functions

Basic functions	Store-and-forward switch, complies with IEEE 802.3
MAC address table	4k
Status and diagnostic indicators	LEDs: US1, US2 (power supply), 2 LEDs per Ethernet port (Link/Activity and Speed)
Additional functions	100 BASE-TX/100BASE-FX (IEEE 802.3u)
	Quality of Service (QoS) prioritization (IEEE 802.1p)
	Energy-efficient Ethernet (IEEE 802.3az)
	10Base-T (IEEE 802.3)

Security functions

Basic functions	Store-and-forward switch, complies with IEEE 802.3
-----------------	--

Electrical properties

Local diagnostics	US1/2 Supply voltage US1, US2 Green LED
	LINK Link status Green LED
Transmission medium	Copper

Supply

Supply voltage (DC)	24 V DC (redundant)
Supply voltage range	9 V DC ... 57 V DC
Residual ripple	3.6 V _{PP} (within the permitted voltage range)
Max. current consumption	143 mA (9 V DC)
Typical current consumption	58 mA

Connection data

Connection technology

Connection name	Power supply
-----------------	--------------

Power supply

Connection method	M12 connector (A-coded)
-------------------	-------------------------

Environmental and real-life conditions

Ambient conditions

Degree of protection	IP65
	IP66
	IP67
Ambient temperature (operation)	-40 °C ... 75 °C
Ambient temperature (storage/transport)	-40 °C ... 85 °C

FL SWITCH 1608 - Industrial Ethernet Switch



1196227

<https://www.phoenixcontact.com/us/products/1196227>

Permissible humidity (operation)	10 % ... 95 % (non-condensing)
Permissible humidity (storage/transport)	10 % ... 95 % (non-condensing)
Shock (operation)	30g (EN 60068-2-27)
Vibration (operation)	in acc. with IEC 60068-2-6: 5g, 150 Hz
Air pressure (operation)	79 kPa ... 108 kPa up to 2000 m above mean sea level (Without derating)
Air pressure (storage/transport)	79 kPa ... 108 kPa up to 2000 m above mean sea level (Without derating)

Standards and regulations

Free from substances that could impair the application of coating	Yes
---	-----

EMC data

Conformance with EMC directives	EN 61000-6-2 EN 61000-4-2 (ESD) Criterion B
	EN 61000-6-2 EN 61000-4-3 (electromagnetic fields) Criterion A
	EN 61000-6-2 EN 61000-4-4 (EFT burst) Criterion A
	EN 61000-6-2 EN 61000-4-5 (surge) Criterion B
	EN 61000-6-2 EN 61000-4-6 (line noise immunity) Criterion A
	EN 61000-6-2 EN 61000-6-4 (interference) Class A
	EN 61000-6-2 EN 61000-6-4 (conducted interference) Class A
Noise immunity	EN 61000-6-2
Electromagnetic compatibility	Conformance with EMC Directive 2014/30/EU
Noise emission	EN 61000-6-4

System properties

Functionality

Basic functions	Store-and-forward switch, complies with IEEE 802.3
-----------------	--

Signaling

Status display	LEDs: US1, US2 (power supply), 2 LEDs per Ethernet port (Link/Activity and Speed)
----------------	---

FL SWITCH 1608 - Industrial Ethernet Switch



1196227

<https://www.phoenixcontact.com/us/products/1196227>

Drawings

Dimensional drawing

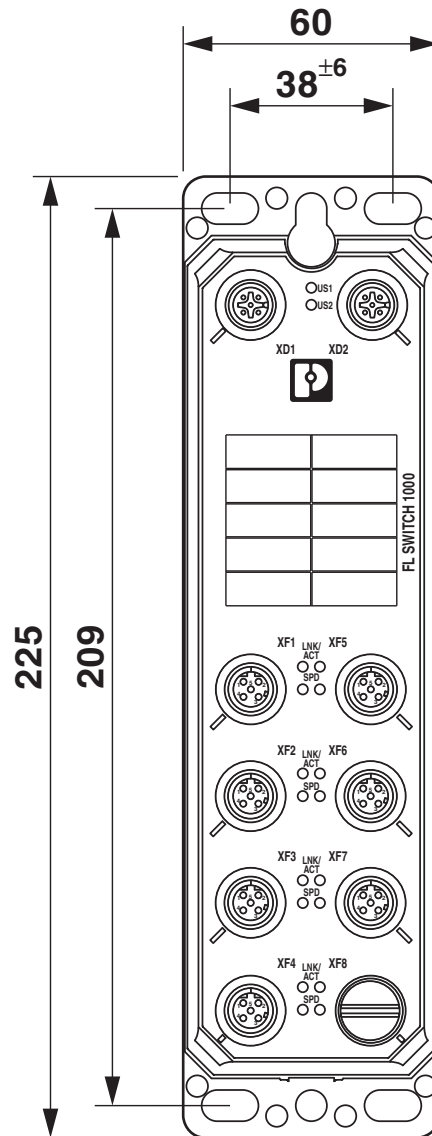

FL SWITCH 1608 - Industrial Ethernet Switch



1196227

<https://www.phoenixcontact.com/us/products/1196227>

Approvals

To download certificates, visit the product detail page: <https://www.phoenixcontact.com/us/products/1196227>



EAC

Approval ID: RU D-DE.GB09.B.00312



cULus Listed

Approval ID: E238705

FL SWITCH 1608 - Industrial Ethernet Switch



1196227

<https://www.phoenixcontact.com/us/products/1196227>

Classifications

ECLASS

ECLASS-11.0	19170402
ECLASS-12.0	19170402
ECLASS-13.0	19170402

ETIM

ETIM 9.0	EC000734
----------	----------

UNSPSC

UNSPSC 21.0	43222600
-------------	----------

FL SWITCH 1608 - Industrial Ethernet Switch



1196227

<https://www.phoenixcontact.com/us/products/1196227>

Environmental product compliance

EU RoHS

Fulfills EU RoHS substance requirements	Yes
Exemption	6(c), 7(a), 7(c)-I

China RoHS

Environment friendly use period (EFUP)	EFUP-50
	An article-related China RoHS declaration table can be found in the download area for the respective article under "Manufacturer declaration". For all articles with EFUP-E, no China RoHS declaration table issued and required.

EU REACH SVHC

REACH candidate substance (CAS No.)	Lead(CAS: 7439-92-1)
SCIP	9eb36802-e863-43cb-84db-945a150551c6

Phoenix Contact 2024 © - all rights reserved

<https://www.phoenixcontact.com>

Phoenix Contact USA
586 Fulling Mill Road
Middletown, PA 17057, United States
(+717) 944-1300
info@phoenixcon.com