

2	3	4	5	6	7	8	9
标记 MARK	ECN编号/变更内容 ECN NO/DEFINITION	修改 REVISE	日期 DATE	核准 APPROVE			

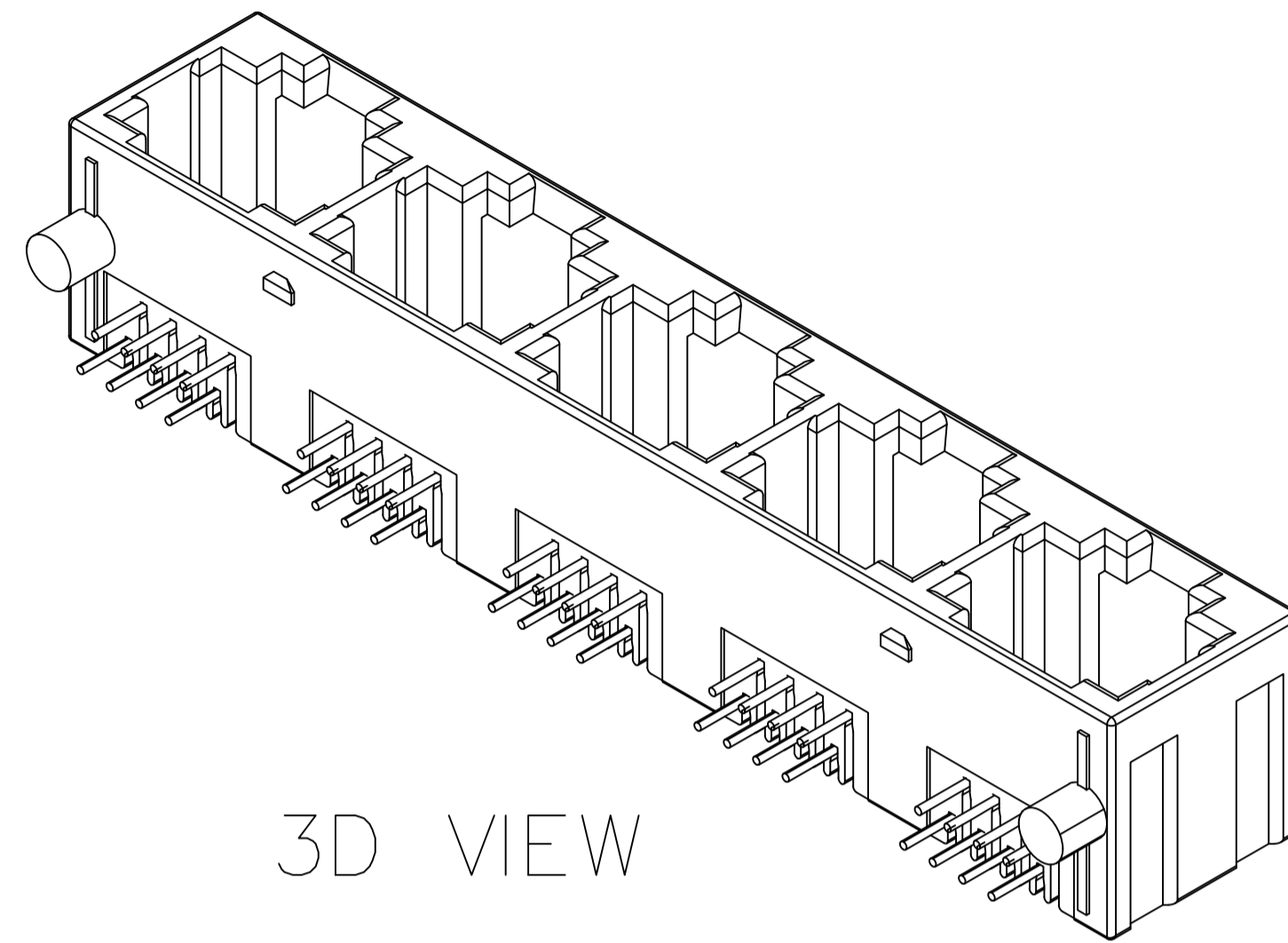
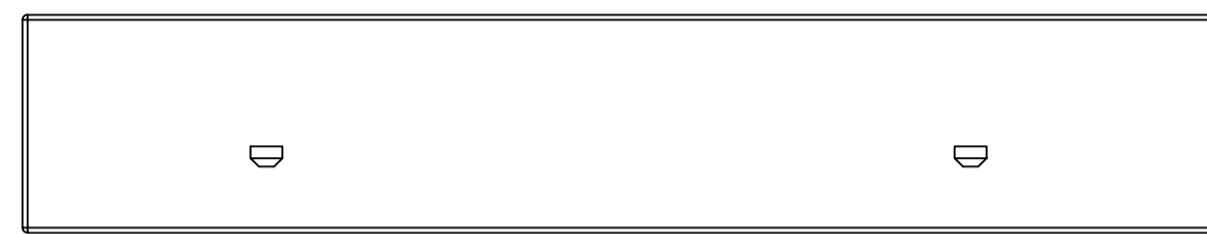

3D VIEW

NOTES:

1. MATERIAL:
  - 1.1. HOUSING: PBT ,COLOR IS BLACK;
  - 1.2. CONTACT: PHOSPHOR BRONZE,  $\phi 0.46 \pm 0.02 \text{mm}$ ;
3. RECINNEBED PCB THICKNESS: 1.0mm Min;
4. ELECTRICAL:
  - 4.1. VOLTAGE RATING: 125 VAC RMS;
  - 4.2. CURRENT RATING: 1.5 AMP;
  - 4.3. CONTACT RESISTANCE: 35MILLIOHMS MAX.;
  - 4.4. WITHSTAND VOLTAGE: 1000 VAC RMS 50(60)Hz, 1MIN.;
  - 4.5. INSULATION RESISTANCE: 1000MEGOHMS MIN @500V DC;
5. MECHANICAL:
  - 5.1. MATING/UNMATING FORCE: 30N MAX.;
  - 5.2. RETENTION STRENGTH: 50N MIN.;
  - 5.3. OPERATING LIFE: 750 CYCLES MIN.;
6. SALT SPRAY TEST: 12H;
7. SOLDERABILITY:  $245 \pm 5^\circ\text{C}, 5 \pm 0.5\text{S}$ ;
8. RESISTANCE TO SOLDER:  $260 \pm 5^\circ\text{C}, 10 \pm 1\text{S}$ ;
9. ENVIRONMENTAL:
  - 8.1. STORAGE TEMPERATURE RANGE:  $-40^\circ\text{C} \sim +85^\circ\text{C}$ ;
  - 8.2. OPERATION TEMPERATURE RANGE:  $-25^\circ\text{C} \sim +70^\circ\text{C}$ ;

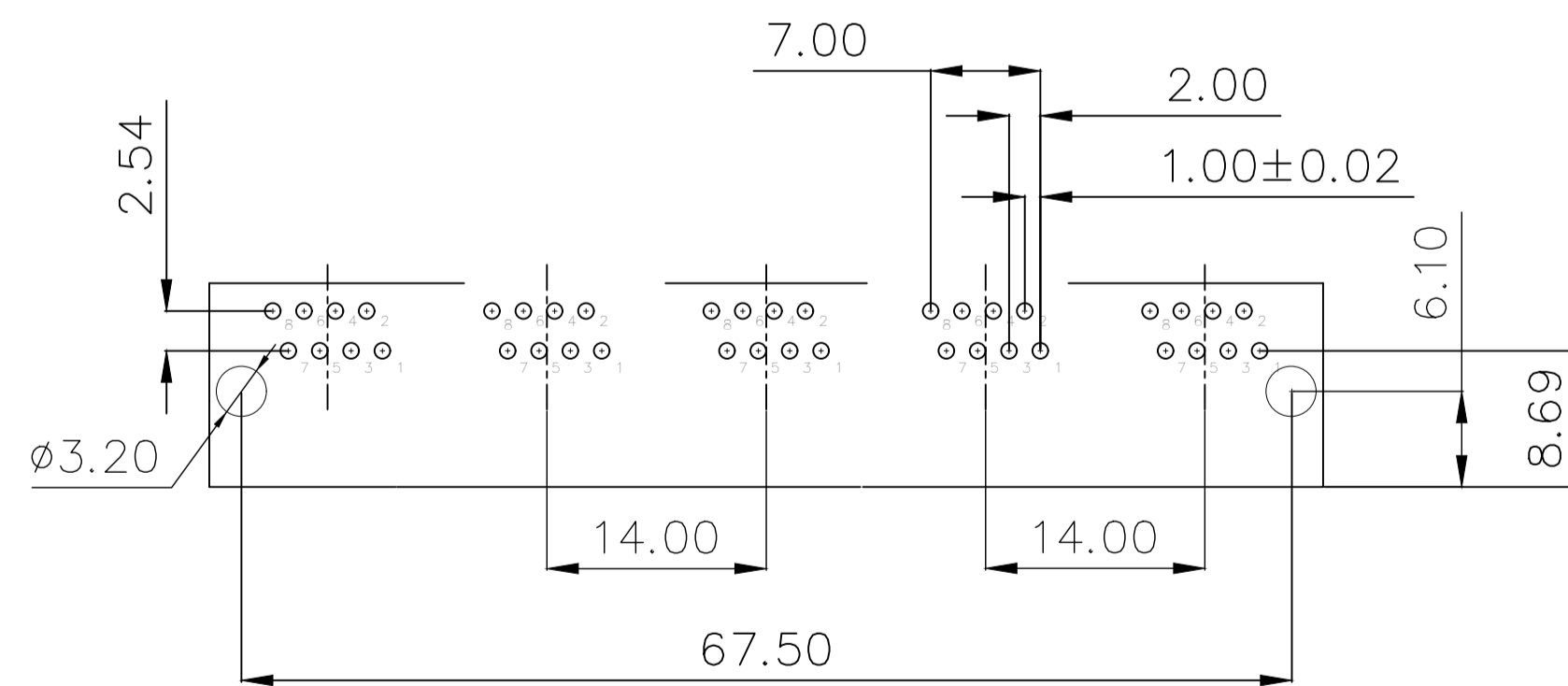
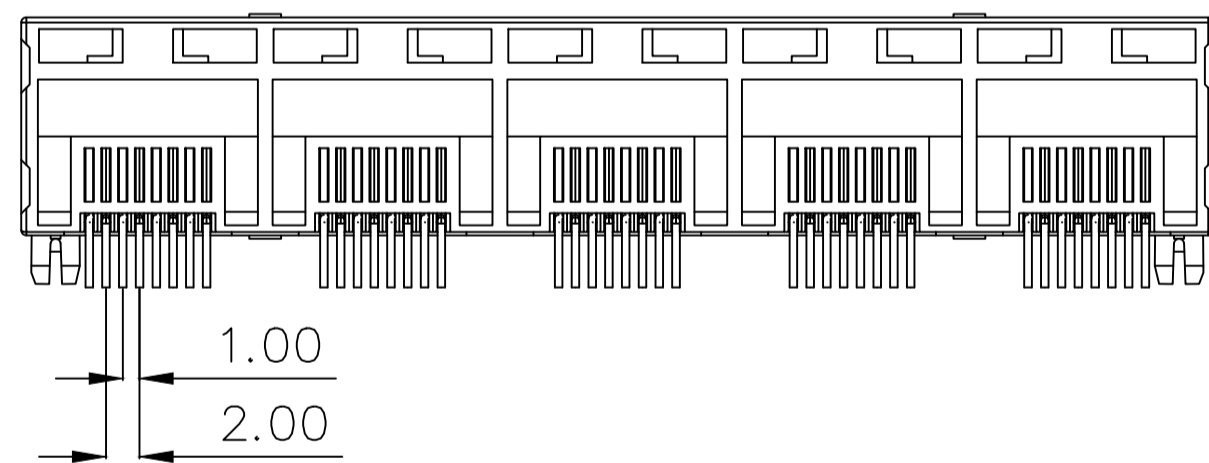
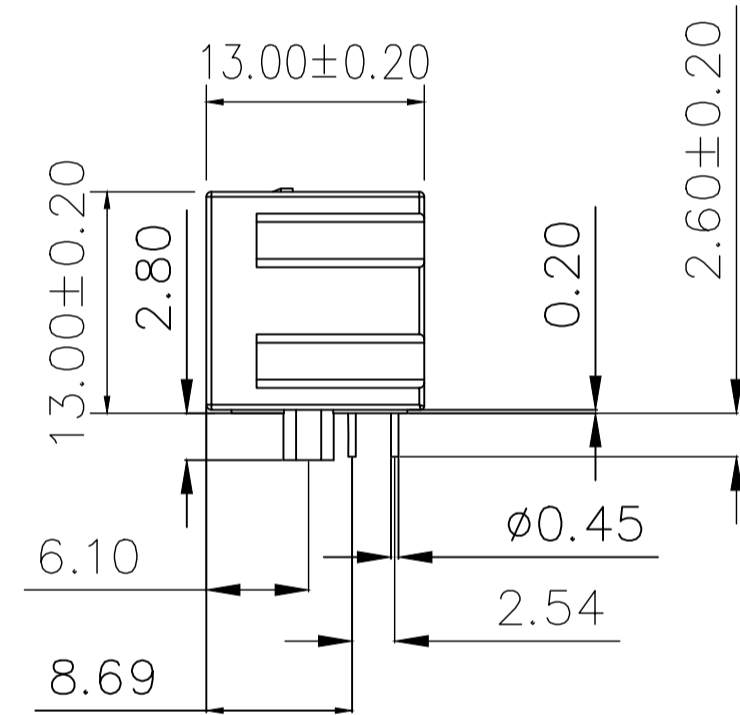
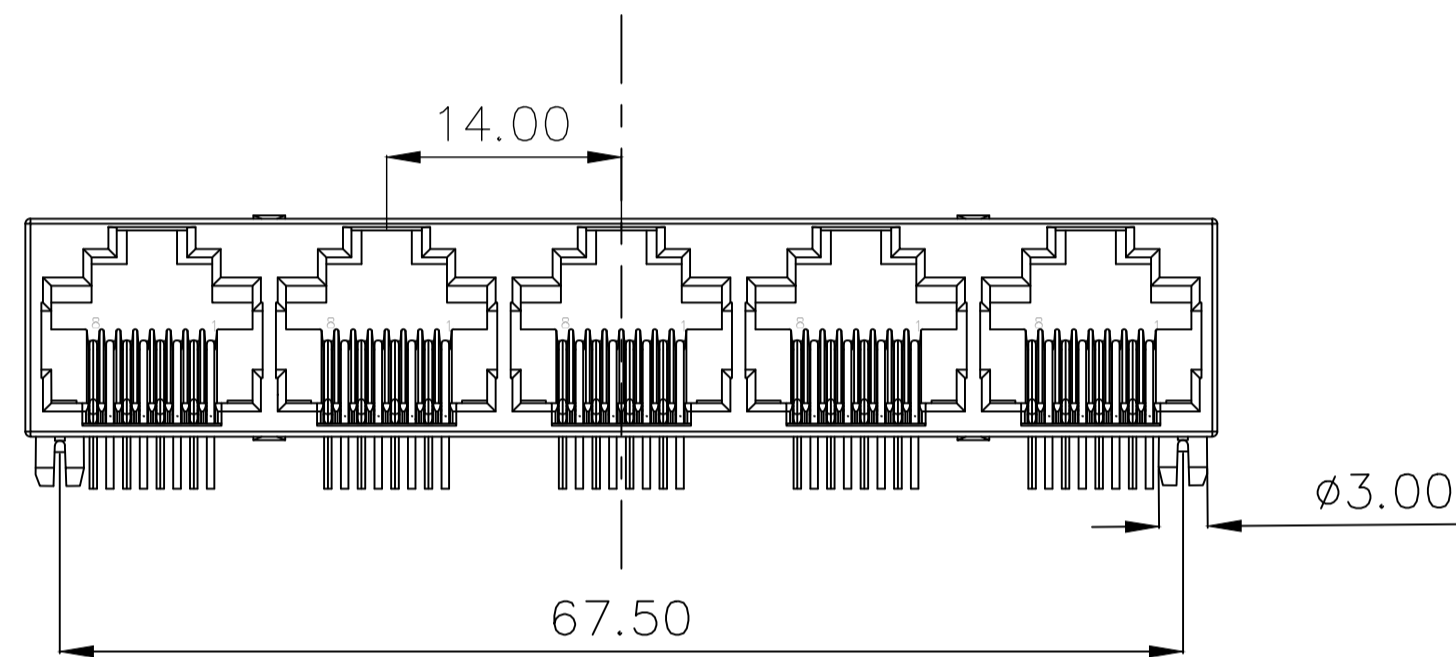

RECOMMENDED PCB LAYOUT  
TOP VIEW(TOL:  $\pm 0.05$ )

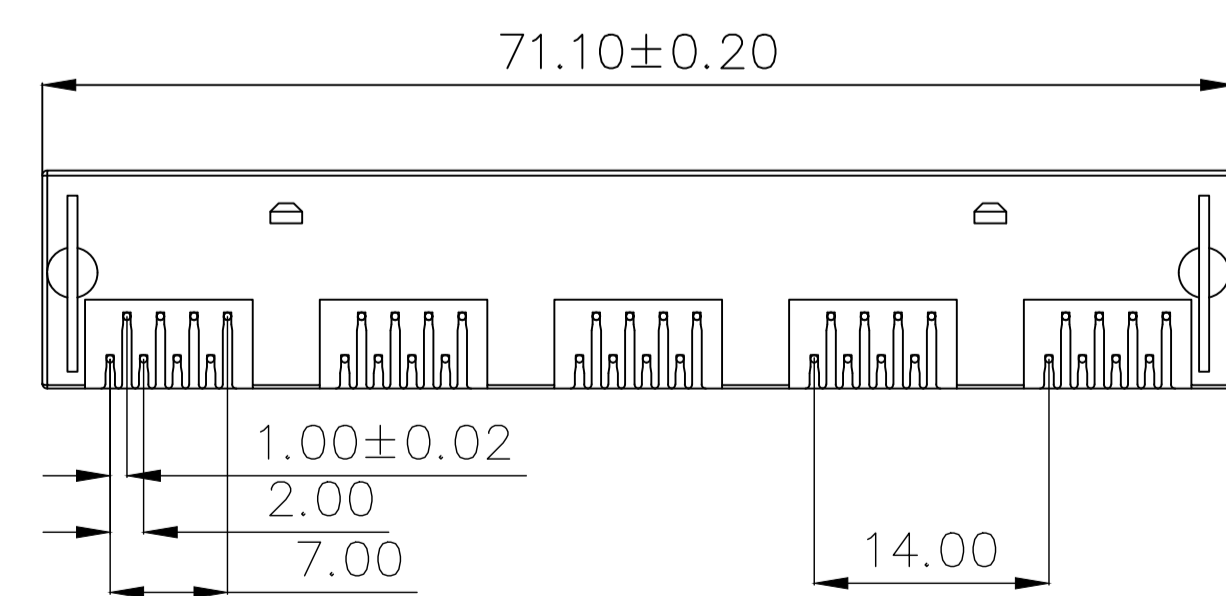

2	接触	铜	镀金G/F	
1	底座	PBT	黑色	
序号	品名	材质	电镀/颜色	备注



深圳市虹成电子有限公司

品名 TITLE	网口
料号 PART NO	HC-WK88-H13-1X5-55QS

UNLESS OTHERWISE, GENERAL TOLERANCE:	比列 SCALE	1:1		
X. xxx $\pm 0.10$ X. xx $\pm 0.20$ X. x $\pm 0.30$	单位 UNIT	MM	制图 DRAW	AhYe
ANGULAR: X. xx° $\pm 1^\circ$ X. x' $\pm 3'$ X. x'' $\pm 5''$	张数 PART NO	1 OF 1	审核 CHECKED	夏操云
	版本 REV	A	批准 APPROVE	赵亮亮

