

TB3-CP80

Accessories – Test Box

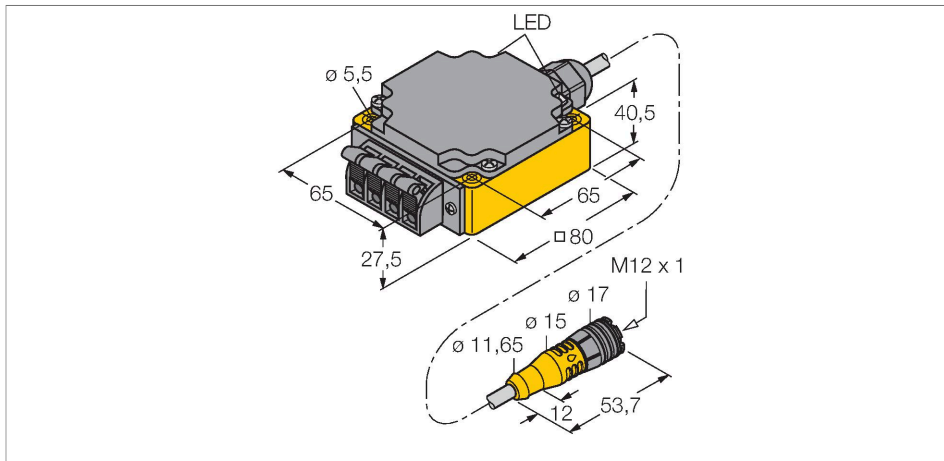

Features

- Universal test device for different sensor types.
- 2-wire DC sensors
- 3-wire and 4-wire DC sensors (npn/pnp)
- NAMUR sensors according to DIN EN 60947-5-6
- Function test without dismantling the sensor
- User-friendly operator and display elements
- Powered via 2 batteries, type E-Block 9 V

Wiring diagram

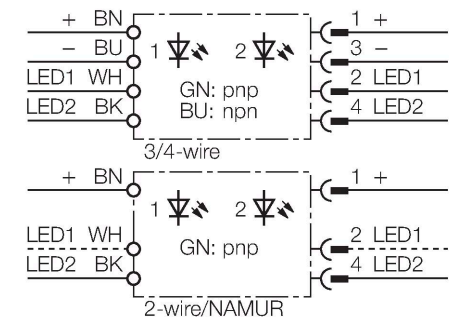

Technical data

Type	TB3-CP80
Ident. no.	6967112
Operating voltage	18 VDC
	Operation via 2 E-Block 9V batteries
Warning	NAMUR sensors may not be operated in the explosion hazardous area in conjunction with the sensor test box. Operational or functional testing in the non-hazardous area is allowed. The approval according to EN60079-0 and -11 does not expire after interconnection with the test device.
Design	Universal test device for PNP, NPN and NAMUR sensors
Dimensions	80 x 80 x 40.5 mm
Electrical connection	Spring type terminals, cable with quick-connect coupling
Switching state	2 × LEDs, Green/Blue

Functional principle

The sensor test box TB3-CP80 is designed to test the functionality of inductive, magnetic field, capacitive and photoelectric sensors directly on-site or in the workshop.

LEDs indicate the switching status of the test box. Clearly visible and highly illuminated display of switching status. In addition, the test box indicates the switching status with an acoustic signal (if connected to pin 4).

The following sensor types can be connected via push button type terminals or via M12 connectors:

- 2-wire DC sensors
 - 3/4-wire DC sensors (npn/pnp)
 - NAMUR sensors according to EN 60947-5-6
- All sensors can be switched to PLUS (green LED) or MINUS (blue LED).