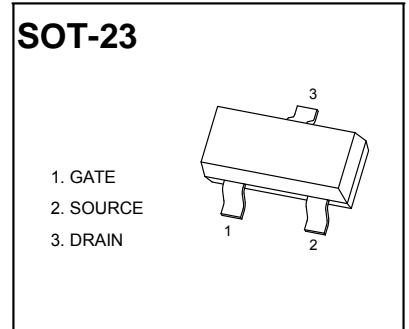

SOT-23 Plastic-Encapsulate MOSFETS
20V P-Channel MOSFET

$V_{(BR)DSS}$	$R_{DS(on)Typ}$	$I_D Max$
-20V	70mΩ@4.5V	-3.0A
	78mΩ@3.3V	

Features

Trench FET Power MOSFET

APPLICATION

- Load Switch for Portable Devices
- DC/DC Converter

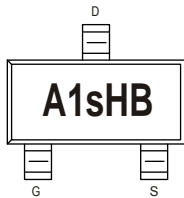
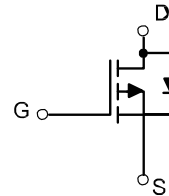
MARKING

Equivalent circuit

PACKAGE SPECIFICATIONS

Package	Reel Size	Reel DIA. (mm)	Q'TY/Reel (pcs)	Box Size (mm)	QTY/Box (pcs)	Carton Size (mm)	Q'TY/Carton (pcs)
SOT-23	7'	330	3000	203×203×195	45000	438×438×220	180000

Maximum Ratings and Thermal Characteristics (TA = 25°C unless otherwise noted)

Parameter	Symbol	Limit	Unit	
Drain-Source Voltage	V_{DS}	-20	V	
Gate-Source Voltage	V_{GS}	±10		
Continuous Drain Current	I_D	$T_A = 25^\circ C$	-3.0	A
		$T_A = 70^\circ C$	-2.5	
Pulsed Drain Current ¹⁾	I_{DM}	-12	A	
Maximum Power Dissipation ²⁾	P_D	$T_A = 25^\circ C$	1.2	W
		$T_A = 70^\circ C$	0.9	
Operating Junction and Storage Temperature Range	T_J, T_{stg}	-50 to 150	°C	
Junction-to-Ambient Thermal Resistance (PCB mounted) ²⁾	R_{thJA}	100	°C/W	

Notes

- ¹⁾ Pulse width limited by maximum junction temperature.
²⁾ Surface Mounted on FR4 Board, $t \leq 5$ sec.

The above data are for reference only.



MOSFET ELECTRICAL CHARACTERISTICS

$T_a=25\text{ }^\circ\text{C}$ unless otherwise specified

Parameter	Symbol	Test Condition	Min	Typ	Max	Units
Static						
Drain-source breakdown voltage	$V_{(BR)DSS}$	$V_{GS} = 0V, I_D = -250\mu A$	-20			V
Gate-source threshold voltage	$V_{GS(th)}$	$V_{DS} = V_{GS}, I_D = -250\mu A$	-0.4	-0.6	-1	
Gate-source leakage	I_{GSS}	$V_{DS} = 0V, V_{GS} = \pm 10V$			± 100	nA
Zero gate voltage drain current	I_{DSS}	$V_{DS} = -20V, V_{GS} = 0V$			-1	μA
Drain-source on-state resistance ^a	$R_{DS(on)}$	$V_{GS} = -4.5V, I_D = -3A$		70	90	m Ω
		$V_{GS} = -3.3V, I_D = -2.0A$		78	100	
Forward transconductance ^a	g_{fs}	$V_{DS} = -5V, I_D = -2.8A$		4.0		S
Dynamic^b						
Input capacitance	C_{iss}	$V_{DS} = -10V, V_{GS} = 0V, f = 1MHz$		330		pF
Output capacitance	C_{oss}			50		
Reverse transfer capacitance	C_{rss}			45		
Total gate charge	Q_g	$V_{DS} = -10V, V_{GS} = -4.5V, I_D = -3A$		6.6		nC
				0.8		
Gate-source charge	Q_{gs}	$V_{DS} = -10V, V_{GS} = -4.5V, I_D = -3A$		0.7		
Gate-drain charge	Q_{gd}			1.4		
Turn-on delay time	$t_{d(on)}$	$V_{DD} = -10V, R_L = 10\Omega,$ $I_D = -3A,$ $V_{GEN} = -4.5V, R_g = 3.3\Omega$		11		ns
Rise time	t_r			12		
Turn-off delay time	$t_{d(off)}$			18		
Fall time	t_f			30		
Drain-source body diode characteristics						
Continuous source-drain diode current	I_S	$T_C = 25^\circ C$			-1.5	A
Body diode voltage	V_{SD}	$I_S = -2A$		-0.85	-1.2	V

a) Pulse test: pulse width $\leq 300\mu s$, duty cycle $\leq 2\%$

b) Guaranteed by design, not subject to production testing

Typical Characteristics

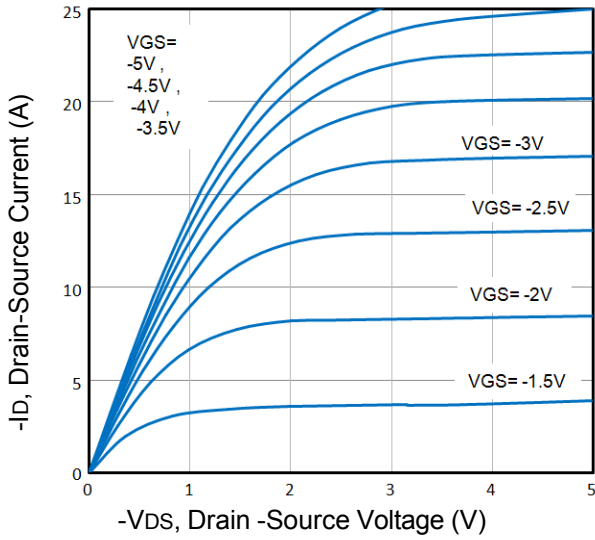

Fig1. Typical Output Characteristics

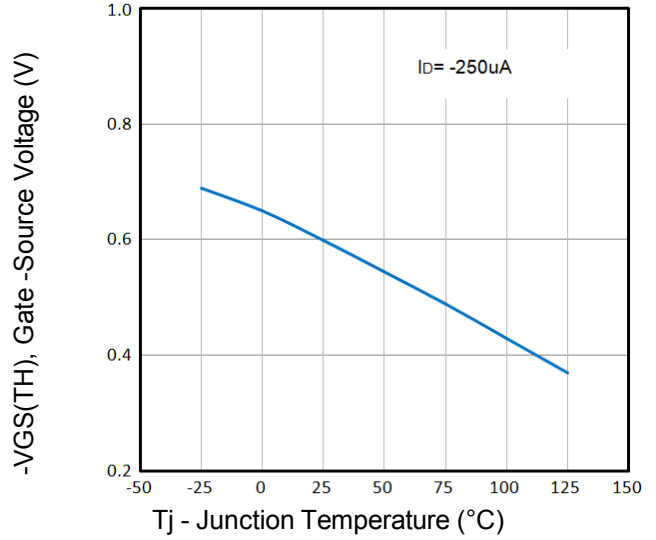

Fig2. Normalized Threshold Voltage Vs. Temperature

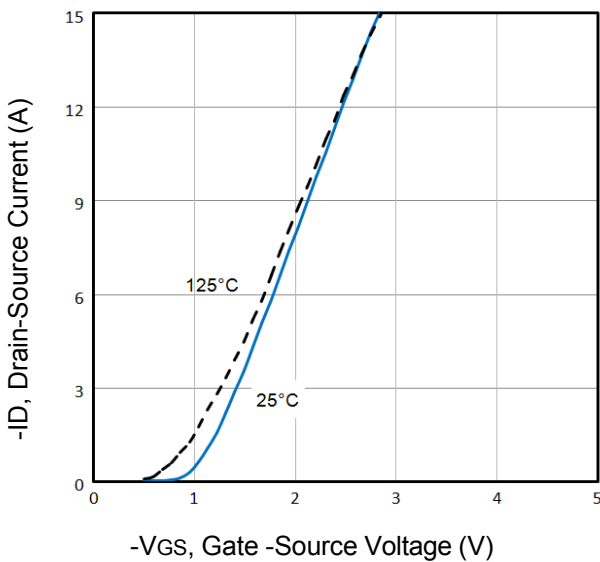

Fig3. Typical Transfer Characteristics

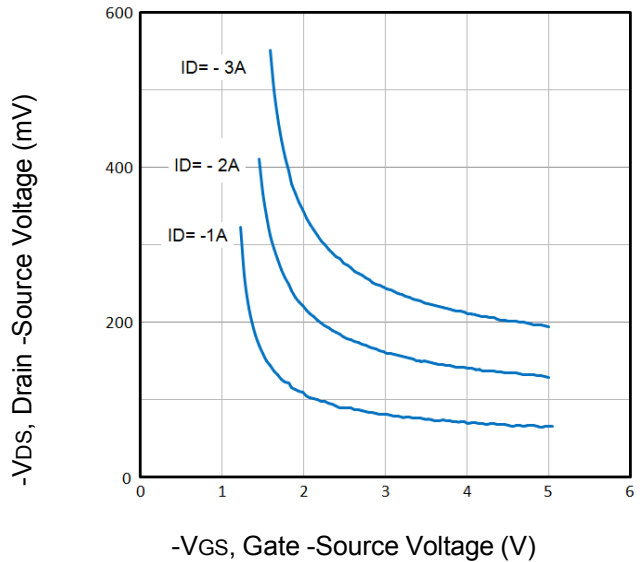

Fig4. Drain-Source Voltage vs Gate-Source Voltage

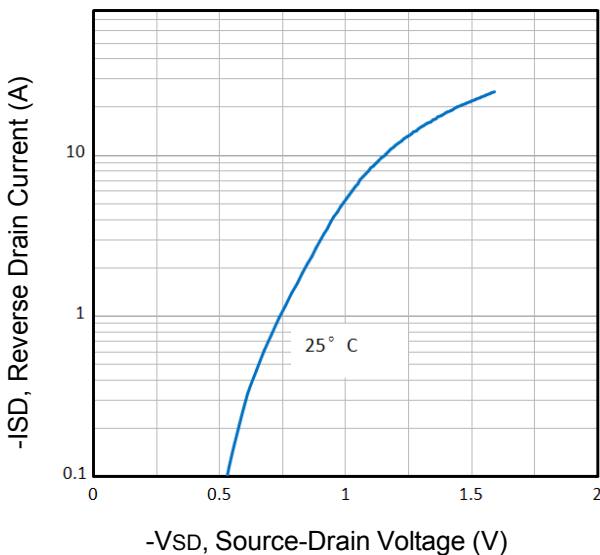

Fig5. Typical Source-Drain Diode Forward Voltage

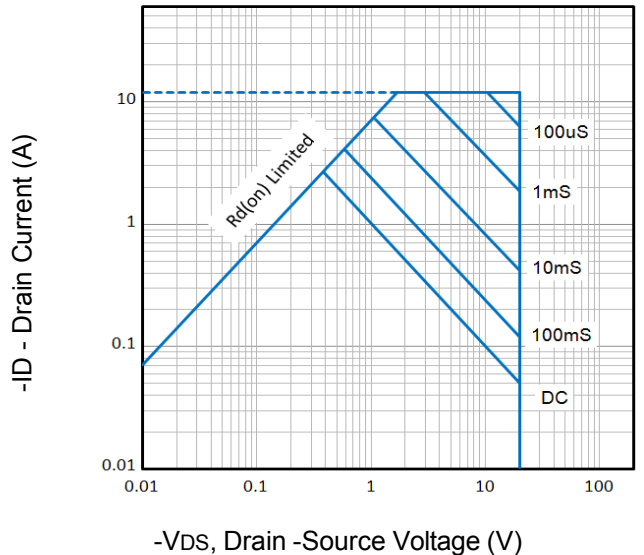

Fig6. Maximum Safe Operating Area

Typical Characteristics

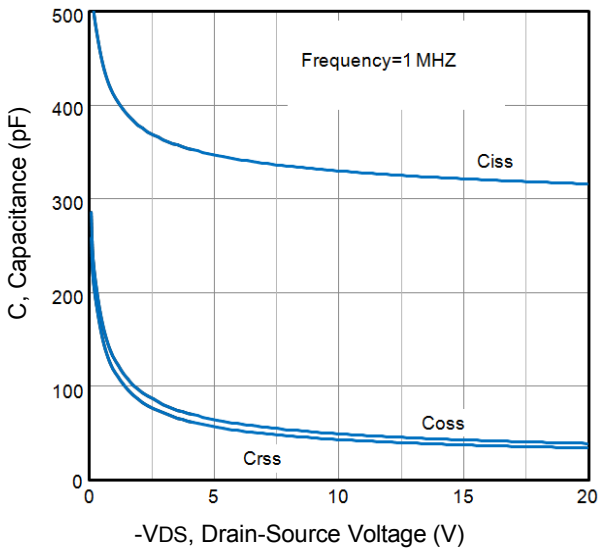

Fig7. Typical Capacitance Vs. Drain-Source Voltage

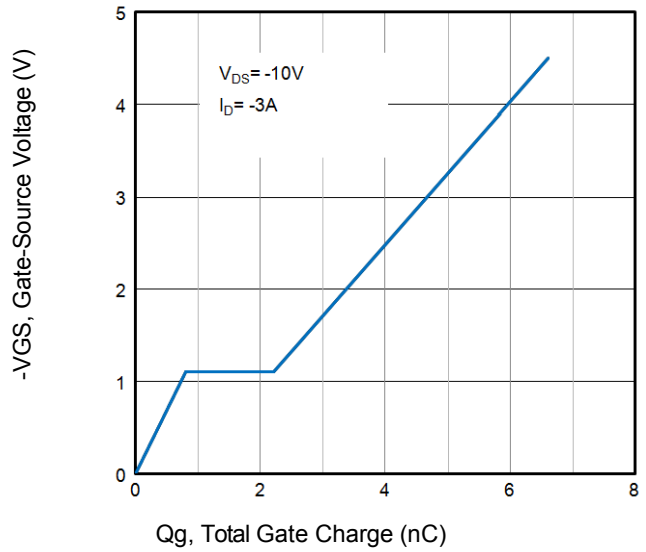

Fig8. Typical Gate Charge Vs. Gate-Source Voltage

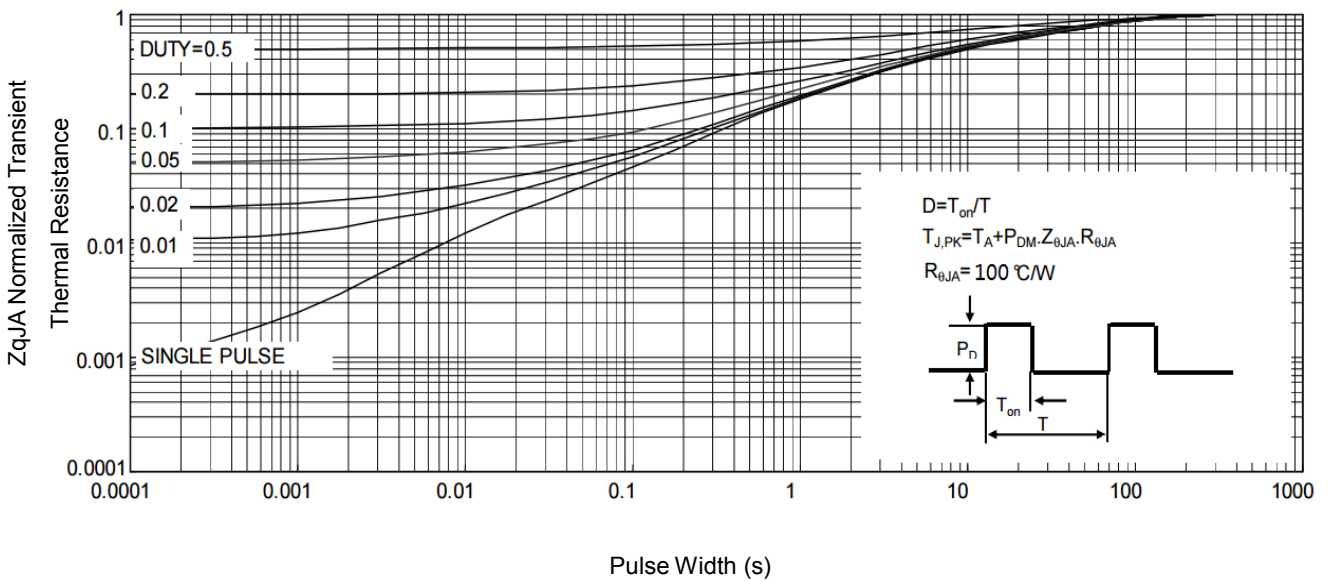

Fig9. Normalized Maximum Transient Thermal Impedance

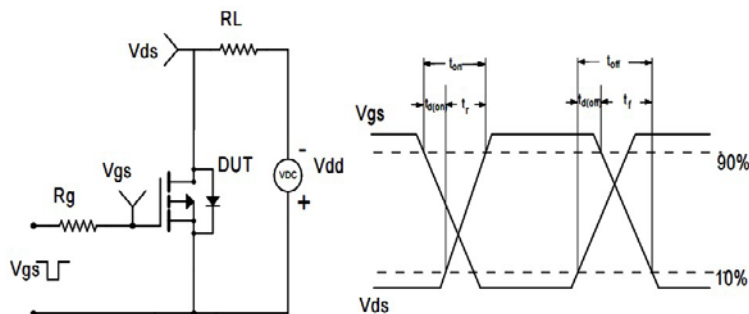
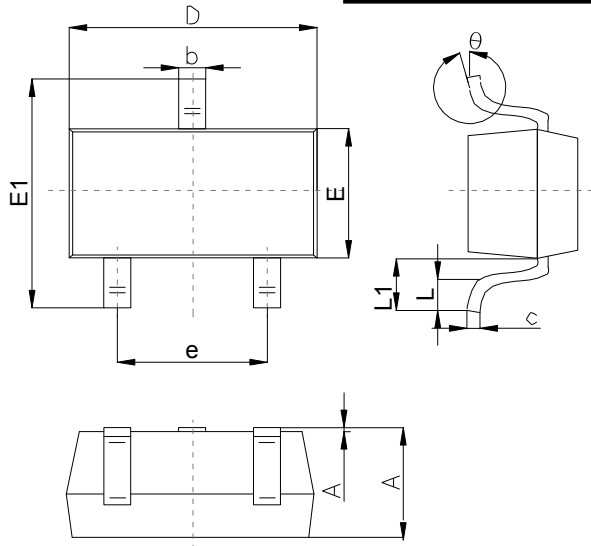

Fig10. Switching Time Test Circuit and waveforms

Outlitne Drawing

SOT-23 Package Outline Dimensions



Symbol	Dimensions In Millimeters		
	Min	Typ	Max
A	0.90		1.40
A1	0.00		0.10
b	0.30		0.50
c	0.08		0.20
D	2.80	2.90	3.10
E	1.20		1.60
E1	2.25		2.80
e	1.80	1.90	2.00
L	0.10		0.50
L1	0.4		0.55
θ	0°		10°

Suggested Pad Layout

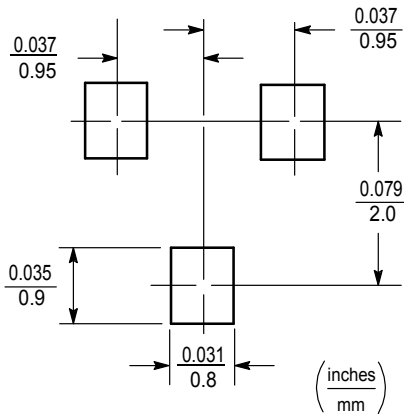

Note:

1. Controlling dimension:in/millimeters.
- 2.General tolerance: ±0.05mm.
- 3.The pad layout is for reference purposes only.