

DEBUR AND BREAK SHARP EDGES

DO NOT SCALE DRAWING

REVISION

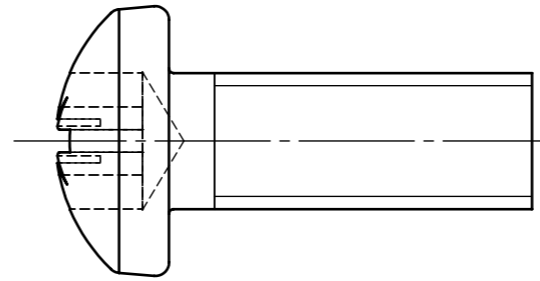
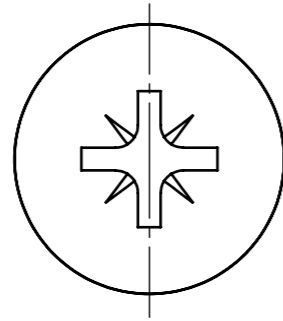

M6 x 16 M/C SCREW TO DIN 7985

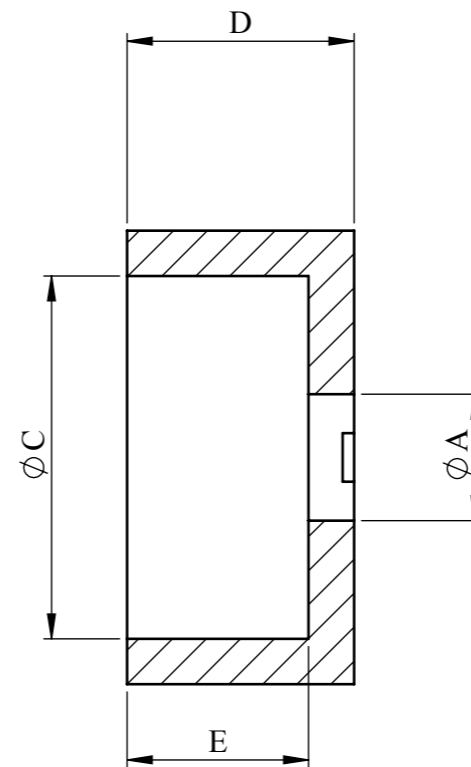
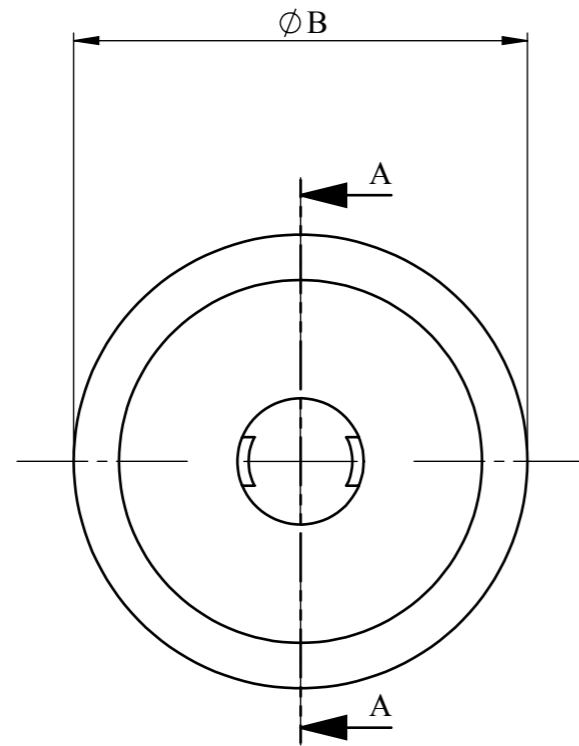

| RETAINING CUP WASHER | | | | |
|----------------------|-------|-------|------|------|
| A | B | C | D | E |
| M6 | 15.00 | 12.00 | 4.00 | 2.70 |

A

DRAWN 01/07/15

NOTES

SCREW - STEEL 4,8, ZINC & CLEAR
RETAINING CUP WASHER - PA6 BLACK



DESIGN RIGHT. TR FASTENINGS LTD, 2003
UNDER NO CIRCUMSTANCES MUST THIS
DRAWING BE COPIED OR DISCLOSED,
WITHOUT FIRST OBTAINING WRITTEN
AUTHORITY.

UNLESS OTHERWISE SPECIFIED:
DIMENSIONS ARE IN MILLIMETERS
SURFACE FINISH:
TOLERANCES:

| | |
|----------------------|----------|
| ISO 2768 m | |
| NAME | DATE |
| DRAWN MARTIN ELLIOTT | 01/07/15 |
| CHK'D | |
| APP'VD | |

CUSTOMER PART No

MATERIAL:

SEE NOTES

HEAT TREATMENT

SEE NOTES

FINISH:

SEE NOTES

TITLE:

FIXING KIT, PANEL, M6

DWG NO.

TRFAKIT0002

A3

PROJECTION

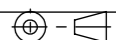

SHEET 1 OF 1