

| ISS / REV | DESCRIPTION | CHANGED BY | DATE     |
|-----------|-------------|------------|----------|
| 5         | DCR 6180    | C.WALLACE  | 04/03/16 |
| 6         | DCR 6624    | K.K-W      | 27/09/17 |
| AA        | CRN 26424   | N.HAWKINS  | 13/03/24 |

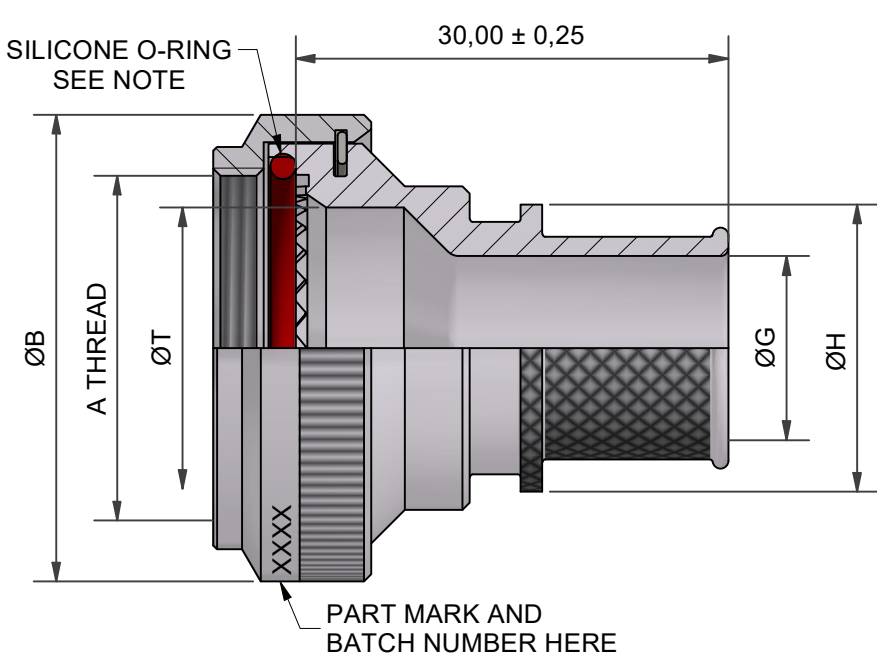

ANGLE 1

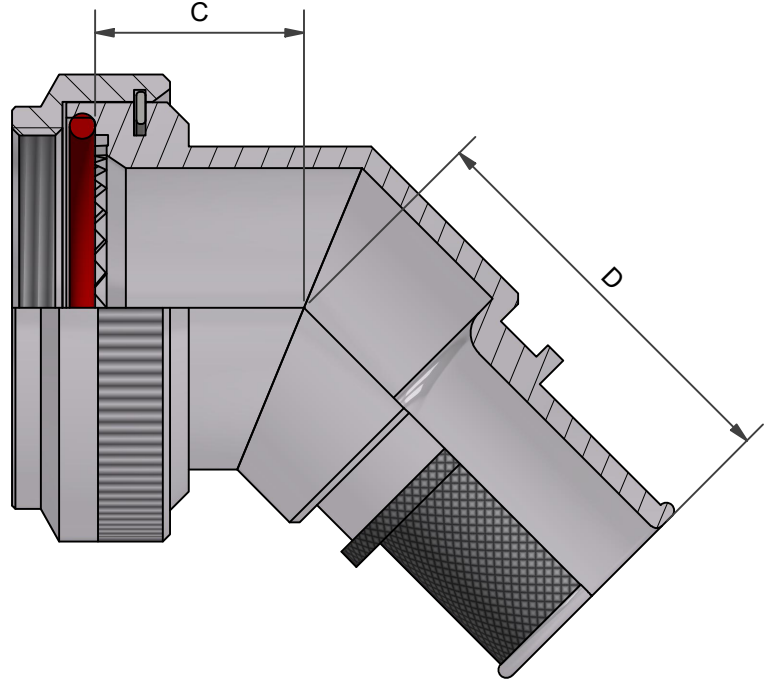

ANGLE 2

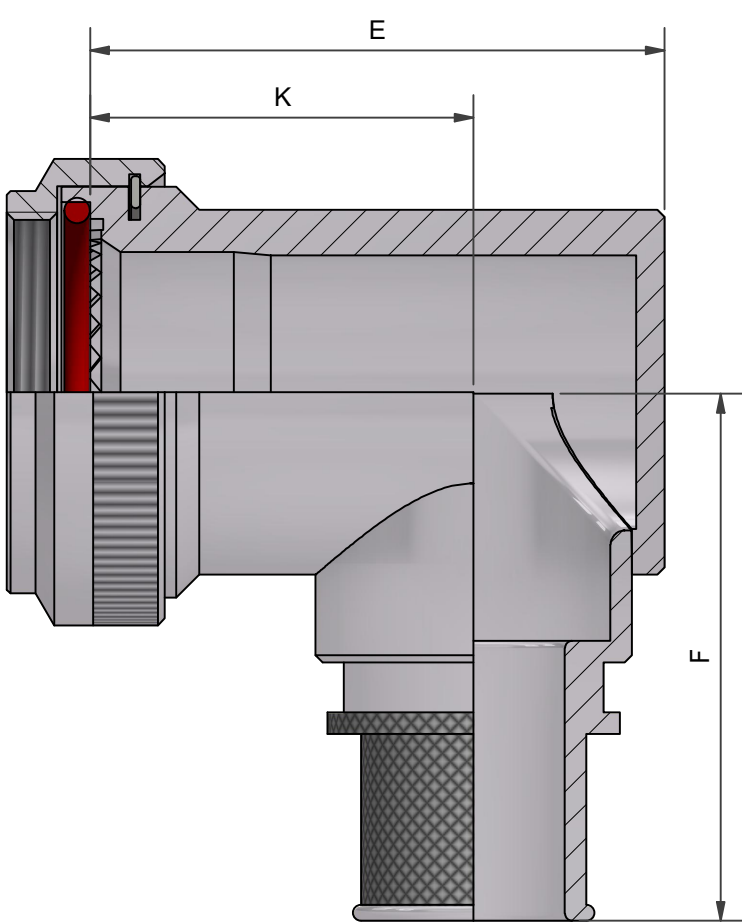

ANGLE 3  
90° BACKSHELL  
ALUMINIUM ALLOY

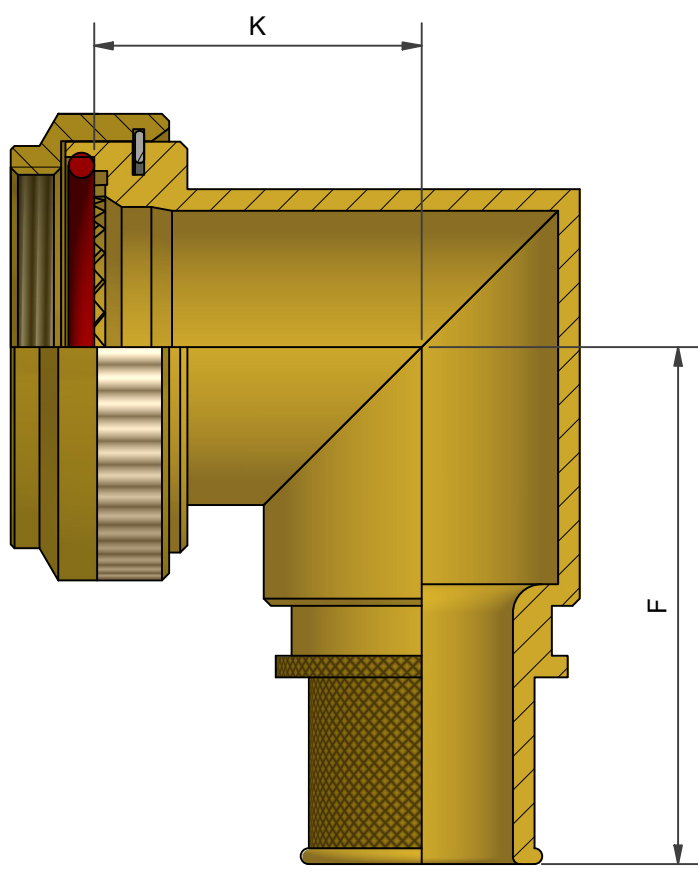

ANGLE 3  
90° BACKSHELL  
STAINLESS STEEL  
NICKEL ALUMINIUM BRONZE

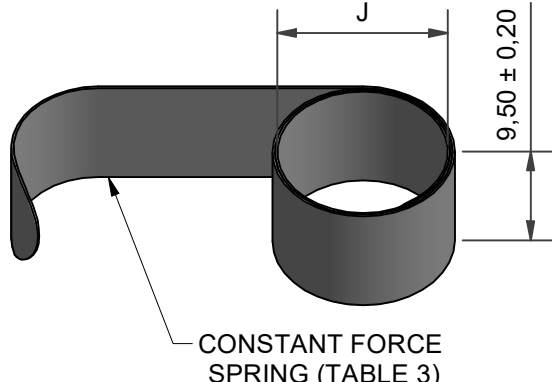

CONSTANT FORCE  
SPRING (TABLE 3)

|  |            |       |        |       |  |  |                            |   |            |      |            |      |            |      |            |   |  |                |
|--|------------|-------|--------|-------|--|--|----------------------------|---|------------|------|------------|------|------------|------|------------|---|--|----------------|
| <table border="1"> <tr> <td>ISSUE/REV</td> <td>CRN</td> </tr> <tr> <td>AA</td> <td>26424</td> </tr> </table>   | ISSUE/REV  | CRN   | AA     | 26424 | <table border="1"> <tr> <td>DATE</td> <td>19/09/2017</td> </tr> <tr> <td>DATE</td> <td>19/09/2017</td> </tr> <tr> <td>DATE</td> <td>19/09/2017</td> </tr> <tr> <td>DATE</td> <td>19/09/2017</td> </tr> <tr> <td>DATE</td> <td>19/09/2017</td> </tr> </table> | DATE   | 19/09/2017                 | DATE                                    | 19/09/2017 | DATE | 19/09/2017 | DATE | 19/09/2017 | DATE | 19/09/2017 | <p>3RD ANGLE PROJECTION NOT TO SCALE</p> <p>UNLESS OTHERWISE SPECIFIED ALL DIMENSIONS IN MILLIMETRES</p> <p>GENERAL TOL<br/>LINEAR +/-0,25MM<br/>ANGULAR +/- 1°</p> <p><b>MATERIAL</b><br/>SEE PART NUMBER BREAKDOWN</p> <p><b>FINISH</b><br/>SEE PART NUMBER BREAKDOWN</p> | <p>PART NUMBER:</p> <p><b>91H SERIES</b></p> <p>TITLE:</p> <p><b>SPRING TERMINATION BACKSHELL</b></p> <p>ASSY USED ON: MIL-DTL-38999 SERIES III &amp; IV</p> | <p>POLAMCO</p> |
| ISSUE/REV  | CRN        |       |        |       |  |  |                            |   |            |      |            |      |            |      |            |   |  |                |
| AA   | 26424      |       |        |       |  |  |                            |   |            |      |            |      |            |      |            |   |  |                |
| DATE   | 19/09/2017 |       |        |       |  |  |                            |   |            |      |            |      |            |      |            |   |  |                |
| DATE   | 19/09/2017 |       |        |       |  |  |                            |   |            |      |            |      |            |      |            |   |  |                |
| DATE   | 19/09/2017 |       |        |       |  |  |                            |   |            |      |            |      |            |      |            |   |  |                |
| DATE   | 19/09/2017 |       |        |       |  |  |                            |   |            |      |            |      |            |      |            |   |  |                |
| DATE   | 19/09/2017 |       |        |       |  |  |                            |   |            |      |            |      |            |      |            |   |  |                |
| <table border="1"> <tr> <td>NCAGE CODE</td> <td>U5792</td> </tr> <tr> <td>WEIGHT</td> <td></td> </tr> </table> | NCAGE CODE | U5792 | WEIGHT |       | <p>THIS DRAWING IS COPYRIGHT AND THE PROPERTY OF POLAMCO LTD IT MUST NOT BE COPIED, USED FOR MANUFACTURE OR OTHERWISE DISCLOSED WITHOUT PRIOR WRITTEN CONSENT OF THE COMPANY.</p>  | <p>POLAMCO LTD, WESTON LOCK, LOWER BRISTOL ROAD BATH BA2 1EP</p> | <p>SHT</p> <p><b>1</b></p> | <p>DRAWING NO:</p> <p><b>P10743</b></p> |            |      |            |      |            |      |            |   |  |                |
| NCAGE CODE   | U5792      |       |        |       |  |  |                            |   |            |      |            |      |            |      |            |   |  |                |
| WEIGHT   |            |       |        |       |  |  |                            |   |            |      |            |      |            |      |            |   |  |                |

THESE DIMENSIONS APPLY IF BACKSHELL IS STAINLESS STEEL OR NICKEL ALUMINIUM BRONZE

TABLE 1

| SHELL SIZE | A THREAD  | ØB MAX | ØT MIN | C MAX | D MAX | E MAX | F MAX | K ±0,5 | F MAX | K ±1,0 |
|------------|-----------|--------|--------|-------|-------|-------|-------|--------|-------|--------|
| 09         | M12 x 1.0 | 18,0   | 6,7    | 13,1  | 25,7  | 25,7  | 30,5  | 17,5   | 32,9  | 15,9   |
| 11         | M15 x 1.0 | 21,0   | 10,2   | 13,9  | 26,9  | 26,7  | 32,2  | 17,5   | 34,1  | 17,3   |
| 13         | M18 x 1.0 | 24,5   | 13,5   | 14,5  | 27,3  | 31,2  | 33,7  | 20,0   | 35,3  | 19,1   |
| 15         | M22 x 1.0 | 29,0   | 16,2   | 15,5  | 28,2  | 37,2  | 35,2  | 24,5   | 37,1  | 21,2   |
| 17         | M25 x 1.0 | 32,5   | 19,4   | 16,1  | 29,0  | 40,2  | 36,9  | 26,7   | 39,0  | 22,8   |
| 19         | M28 x 1.0 | 35,5   | 21,8   | 16,8  | 29,3  | 44,7  | 38,5  | 27,0   | 40,8  | 24,9   |
| 21         | M31 x 1.0 | 37,0   | 25,1   | 17,1  | 30,1  | 49,2  | 40,1  | 30,5   | 42,5  | 25,6   |
| 23         | M34 x 1.0 | 40,0   | 28,2   | 17,7  | 30,5  | 51,7  | 41,6  | 31,5   | 43,9  | 27,1   |
| 25         | M37 x 1.0 | 43,5   | 31,4   | 18,4  | 31,4  | 53,2  | 43,1  | 28,5   | 45,3  | 28,6   |

TABLE 2

| ENTRY SIZE | ØG MIN | ØH MAX | SPRING REF |
|------------|--------|--------|------------|
| 03         | 4,7    | 13,9   | HE050      |
| 04         | 6,3    | 13,9   | HE050      |
| 05         | 7,9    | 15,5   | HE100      |
| 06         | 9,5    | 17,2   | HE100      |
| 07         | 11,1   | 18,7   | HE100      |
| 08         | 12,7   | 20,3   | HE200      |
| 09         | 14,2   | 21,9   | HE200      |
| 10         | 15,8   | 23,5   | HE200      |
| 11         | 17,4   | 25,1   | HE200      |
| 12         | 19,0   | 26,7   | HE300      |
| 13         | 20,6   | 28,3   | HE300      |
| 14         | 22,2   | 29,9   | HE300      |
| 15         | 23,8   | 31,5   | HE300      |
| 16         | 25,4   | 33,1   | HE300      |
| 17         | 27,0   | 34,7   | HE400      |
| 18         | 28,6   | 36,3   | HE400      |
| 19         | 30,2   | 37,9   | HE400      |
| 20         | 31,8   | 39,5   | HE400      |
| 21         | 33,3   | 41,1   | HE400      |
| 22         | 35,0   | 42,7   | HE400      |
| 23         | 36,5   | 44,3   | HE400      |
| 24         | 38,1   | 45,9   | HE400      |

TABLE 3

| SPRING REF | J MAX (UNCONSTRAINED) |
|------------|-----------------------|
| HE 050     | 7,5                   |
| HE 100     | 9,1                   |
| HE 200     | 12,8                  |
| HE 300     | 17,9                  |
| HE 400     | 21,8                  |

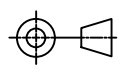

TABLE 4

| CODE | MATERIAL / FINISH   |
|------|---|
| 1-C  | ALUMINIUM / ELECTROLESS NICKEL                                  |
| 1-B  | ALUMINIUM / CADMIUM OLIVE DRAB OVER ELECTROLESS NICKEL          |
| 1-ZB | ALUMINIUM / ZINC COBALT OLIVE DRAB OVER ELECTROLESS NICKEL      |
| 1-ZK | ALUMINIUM / ZINC COBALT BLACK OVER ELECTROLESS NICKEL           |
| 1-ZN | ALUMINIUM / ZINC NICKEL BLACK PASSIVATE OVER ELECTROLESS NICKEL |
| 4-J  | STAINLESS STEEL 300 SERIES / PASSIVATE                          |
| 46-J | STAINLESS STEEL 316 / PASSIVATE                                 |
| 2-Z  | NICKEL ALUMINIUM BRONZE / SHOT BLAST                            |

SEE SS0076 FOR FULL RANGE OF FINISH OPTIONS  
NOTE: VITON O-RING SUPPLIED WITH STAINLESS BACKSHELL

91H1-17-08-1-C-HE200

SERIES \_\_\_\_\_  
CONNECTOR INTERFACE \_\_\_\_\_  
ANGLE \_\_\_\_\_  
SHELL SIZE (TABLE 1) \_\_\_\_\_  
ENTRY SIZE (TABLE 2) \_\_\_\_\_  
MATERIAL AND FINISH (TABLE 4) \_\_\_\_\_  
SPRING REF (TABLE 3) \_\_\_\_\_  
OMIT IF NO SPRING REQUIRED  
SPRING REFERENCE NOT INCLUDED IN PART MARKING  
e.g 91H1-17-08-1-C [BATCH NUMBER]

|                    |            |             |            |  |   |  |   |  |  |  |  |            |               |                    |        |  |
|--------------------|------------|-------------|------------|--|---|--|---|--|--|--|--|------------|---------------|--------------------|--------|--|
| <b>DRAWN</b>       | K.K-W      | <b>DATE</b> | 19/09/2017 | <br>3RD ANGLE PROJECTION NOT TO SCALE | <b>PART NUMBER:</b>   | 91H SERIES   |   |  |  | <br>POLAMCO |  |            |               |                    |        |  |
| <b>SALES APPR</b>  | M.PAUL     | <b>DATE</b> | 19/09/2017 |  | <b>TITLE:</b>   |  |   |  |  |  | SPRING TERMINATION BACKSHELL                                     |            |               |                    |        |  |
| <b>DESIGN APPR</b> | K.SHEPPARD | <b>DATE</b> | 19/09/2017 |  | <small>UNLESS OTHERWISE SPECIFIED ALL DIMENSIONS IN MILLIMETRES</small><br><b>GENERAL TOL</b><br><small>LINEAR +/-0,25MM</small><br><small>ANGULAR +/- 1°</small> | <b>ASSY USED ON:</b>   | <small>THIS DRAWING IS COPYRIGHT AND THE PROPERTY OF POLAMCO LTD IT MUST NOT BE COPIED, USED FOR MANUFACTURE OR OTHERWISE DISCLOSED WITHOUT PRIOR WRITTEN CONSENT OF THE COMPANY.</small> |  |  |  |  |            |               |                    |        |  |
| <b>PROD APPR</b>   | K.SMITH    | <b>DATE</b> | 19/09/2017 |  |   | <b>MATERIAL</b><br>SEE PART NUMBER BREAKDOWN<br><br><b>FINISH</b><br>SEE PART NUMBER BREAKDOWN |   |  |  |  | <b>POLAMCO LTD, WESTON LOCK, LOWER BRISTOL ROAD BATH BA2 1EP</b> | <b>SHT</b> | 2             | <b>DRAWING NO:</b> | P10743 |  |
| <b>QUAL APPR</b>   | P.REES     | <b>DATE</b> | 19/09/2017 |  |   |  |   |  |  |  | <b>NCAGE CODE</b>  | U5792      | <b>WEIGHT</b> |                    |        |  |
| <b>ISSUE/REV</b>   | AA         | <b>CRN</b>  | 26424      |  |   |  |   |  |  |  |  |            |               |                    |        |  |