

# 1.5MHz, Low Cost Micro Power Operational Amplifiers

## Features

- Operates on 2.1V ~ 5.5V Supplies
- Low Quiescent Current: 85 $\mu$ A
- Gain Bandwidth Product: 1.5MHz
- Slew Rate: 1V/ $\mu$ s
- Rail-to-Rail Output
- Unity Gain Stable
- No Phase Reversal
- Extended Temperature Ranges  
From -40°C to +125°C
- Small Packaging  
COS321 available in SOT23-5/SOP8  
COS358 available in SOP8/MSOP8  
/TSSOP8  
COS324 available in SOP14/TSSOP14

## Applications

- Portable Equipment
- Sensor Conditioning
- Analog Active Filters
- Medical Equipment
- Audio Output
- White Goods
- Battery or Solar Powered Systems

## General Description

The COS321 (single), COS358 (dual) and COS324 (quad) are micro-power, low cost amplifiers operated on 2.1V to 5.5V supplies. Despite their low quiescent current, the COS358 family provides excellent overall performance and versatility. They have rail-to-rail output voltage range which extends to within 10mV of each rail, providing the maximum output dynamic range with excellent overdrive recovery.

COS358 family is unity gain stable and has a gain bandwidth product of 1.5MHz (typical). They provide high CMRR and PRSS performance and can operate from a single supply voltage as low as 2.1V. These features make the COS358 family well suited for single-supply, battery-powered applications. They can be used as plus-in replacements for many commercially available op-amps to reduce power and improve output range and performance.

Rev1.0  
Copyright©2018 Cosine Nanoelectronics Inc. All rights reserved

The information provided here is believed to be accurate and reliable. Cosine Nanoelectronics assumes no liability for inaccuracies and omissions. Specifications described and contained here are subjected to change without notice on the purpose of improving the design and performance. All of this information described herein should not be implied or granted for any third party.

## 1. Pin Configuration and Functions

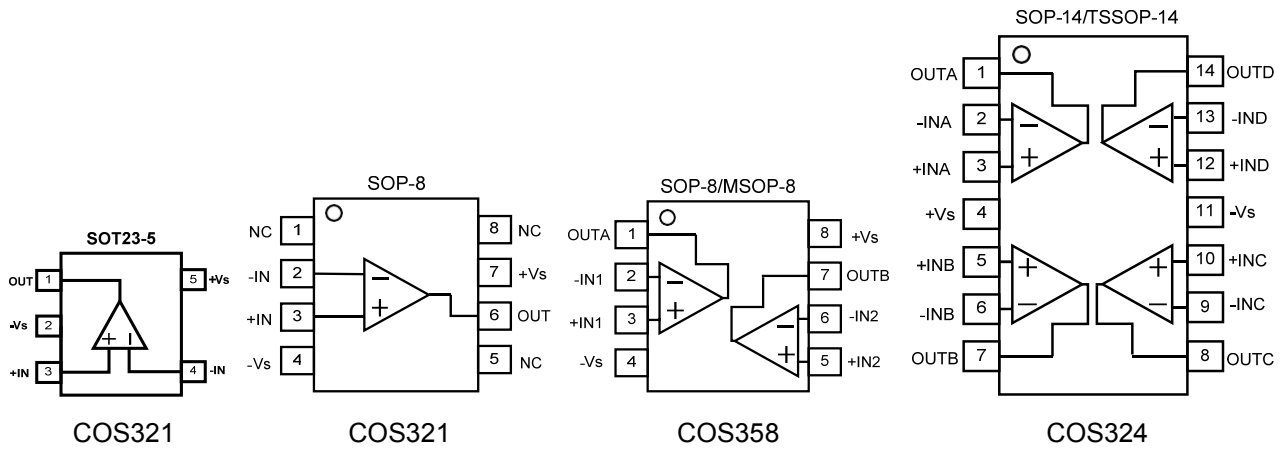

### Pin Functions

Name	Description	Note
+Vs	Positive power supply	A bypass capacitor of 0.1 $\mu$ F as close to the part as possible should be placed between power supply pins or between supply pins and ground.
-Vs	Negative power supply or ground	If it is not connected to ground, bypass it with a capacitor of 0.1 $\mu$ F as close to the part as possible.
-IN	Negative input	Inverting input of the amplifier. Voltage range of this pin can go from -Vs -0.3V to +Vs - 1V.
+IN	Positive input	Non-inverting input of the amplifier. This pin has the same voltage range as -IN.
OUT	Output	The output voltage range extends to within millivolts of each supply rail.
NC	No connection	

## 2. Package and Ordering Information

Model	Channel	Order Number	Package	Package Option	Marking Information
COS321	1	COS321TR	SOT23-5	Tape and Reel, 3000	C321
		COS321SR	SOP-8	Tape and Reel, 3000	COS321
COS358	2	COS358SR	SOP-8	Tape and Reel, 3000	COS358
		COS358MR	MSOP-8	Tape and Reel, 3000	COS358
		COS358TR	TSSOP-8	Tape and Reel, 3000	COS358
COS324	4	COS324SR	SOP-14	Tape and Reel, 3000	COS324
		COS324TR	TSSOP-14	Tape and Reel, 3000	COS324

### 3. Product Specification

#### 3.1 Absolute Maximum Ratings <sup>(1)</sup>

Parameter	Rating	Units
Power Supply: +Vs to -Vs	6.0	V
Input Voltage	-Vs -0.5V to +Vs + 0.5V	V
Input Current <sup>(2)</sup>	10	mA
Storage Temperature Range	-65 to 150	°C
Junction Temperature	150	°C
Operating Temperature Range	-40 to 125	°C
ESD Susceptibility, HBM	2000	V

(1) Stresses exceeding the absolute maximum ratings may damage the device. The device may not function or be operable above the recommended operating conditions and stressing the parts to these levels is not recommended. In addition, extended exposure to stresses above the recommended operating conditions may affect device reliability. The absolute maximum ratings are stress ratings only.

(2) Input terminals are diode-clamped to the power-supply rails. Input signals that can swing more than 0.5V beyond the supply rails should be current-limited to 10mA or less.

#### 3.2 Thermal Data

Parameter	Rating	Unit
Package Thermal Resistance	190 (SOT23-5) 206 (MSOP8) 155 (SOP8) 105 (TSSOP14) 82 (SOP14)	°C/W

#### 3.3 Recommended Operating Conditions

Parameter	Rating	Unit
DC Supply Voltage	2.1V ~ 5.5V	V
Input common-mode voltage range	-Vs ~ +Vs	V
Operating ambient temperature	-40 to +85	°C

### 3.4 Electrical Characteristics

(+V<sub>S</sub>=+5V, -V<sub>S</sub>=0, V<sub>CM</sub>=V<sub>S</sub>/2, T<sub>A</sub>=+25°C, R<sub>L</sub>=10kΩ to V<sub>S</sub>/2, unless otherwise noted)

Parameter	Symbol	Conditions	Min	Typ	Max	Unit
<b>Input Characteristics</b>						
Input Offset Voltage	V <sub>OS</sub>			1.0	5.0	mV
Input Offset Voltage Drift	ΔV <sub>OS</sub> /ΔT	-40 to 125°C		5		μV/°C
Input Bias Current	I <sub>B</sub>			2.5		pA
Input Offset Current	I <sub>OS</sub>			2.5		pA
Common-Mode Voltage Range	V <sub>CM</sub>	V <sub>S</sub> = 5.5V	-0.1		4.5	V
Common-Mode Rejection Ratio	CMRR	V <sub>CM</sub> = 0.1V to 4.5V		125		dB
Open-Loop Voltage Gain	AOL	V <sub>O</sub> = 0.2V to 4.5V		120		dB
<b>Output Characteristics</b>						
Output Voltage Swing from Rail		R <sub>L</sub> = 100kΩ		1		mV
		R <sub>L</sub> = 10kΩ		10		mV
		R <sub>L</sub> = 2kΩ		40		mV
Short-Circuit Current	I <sub>SR</sub>	Sourcing		45		mA
	I <sub>SK</sub>	Sinking		50		mA
<b>Power Supply</b>						
Operating Voltage Range			2.1		5.5	V
Power Supply Rejection Ratio	PSRR	V <sub>S</sub> = +1.8V to +5.5V	80	100		dB
Quiescent Current / Amplifier	I <sub>Q</sub>			85		μA
<b>Dynamic Performance</b>						
Gain Bandwidth Product	GBWP	G = +1		1.5		MHz
Slew Rate	SR	G = +1, 2V Output Step		1		V/μs
<b>Noise Performance</b>						
Voltage Noise Density	e <sub>n</sub>	f = 1kHz		28		nV/√Hz

## 4.0 Application Notes

### Driving Capacitive Loads

Driving large capacitive loads can cause stability problems for voltage feedback op amps. As the load capacitance increases, the feedback loop's phase margin decreases, and the closed loop bandwidth is reduced. This produces gain peaking in the frequency response, with overshoot and ringing in the step response. A unity gain buffer ( $G = +1$ ) is the most sensitive to capacitive loads, but all gains show the same general behavior.

When driving large capacitive loads with these op amps (e.g.,  $> 100$  pF when  $G = +1$ ), a small series resistor at the output ( $R_{ISO}$  in Figure 1) improves the feedback loop's phase margin (stability) by making the output load resistive at higher frequencies. It does not, however, improve the bandwidth.

To select  $R_{ISO}$ , check the frequency response peaking (or step response overshoot) on the bench. If the response is reasonable, you do not need  $R_{ISO}$ . Otherwise, start  $R_{ISO}$  at  $1\text{ k}\Omega$  and modify its value until the response is reasonable.

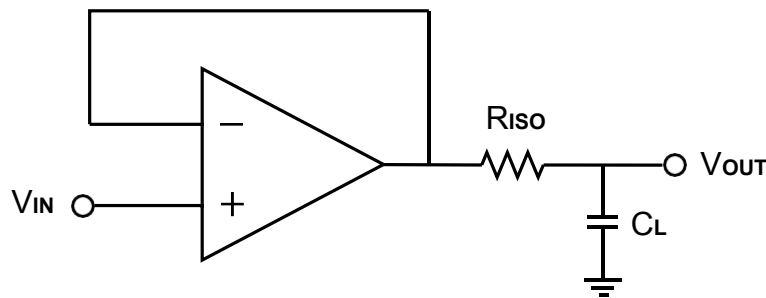

Figure 1. Indirectly Driving Heavy Capacitive Load

An improvement circuit is shown in Figure 2. It provides DC accuracy as well as AC stability.  $R_F$  provides the DC accuracy by connecting the inverting signal with the output,  $C_F$  and  $R_{ISO}$  serve to counteract the loss of phase margin by feeding the high frequency component of the output signal back to the amplifier's inverting input, thereby preserving phase margin in the overall feedback loop.

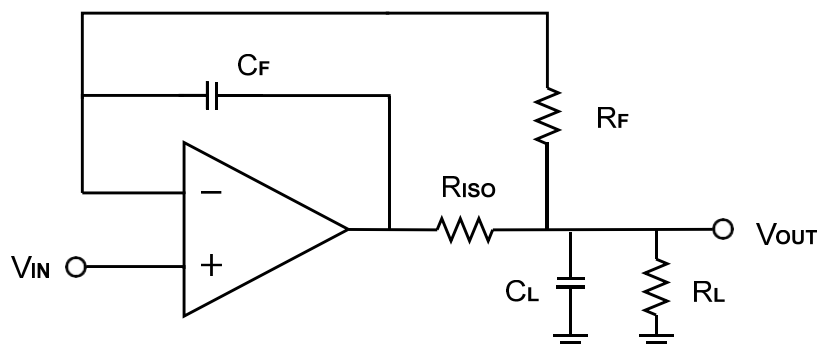

Figure 2. Indirectly Driving Heavy Capacitive Load with DC Accuracy

For noninverting configuration, there are two others ways to increase the phase margin: (a) by increasing the amplifier's gain or (b) by placing a capacitor in parallel with the feedback resistor to counteract the parasitic capacitance associated with inverting node, as shown in Figure 3.

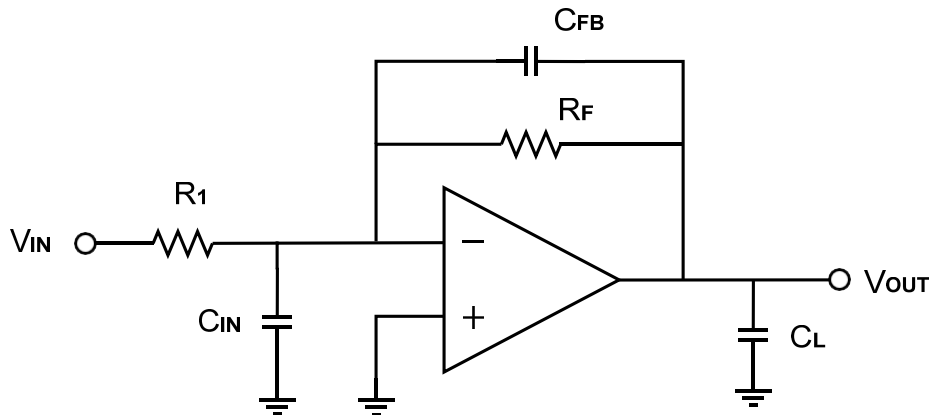

Figure 3. Adding a Feedback Capacitor in the Noninverting Configuration

## Power-Supply Bypassing and Layout

The COS321/2/4 operates from a single +2.1V to +5.5V supply or dual  $\pm 1.05V$  to  $\pm 2.75V$  supplies. For single-supply operation, bypass the power supply +Vs with a  $0.1\mu F$  ceramic capacitor which should be placed close to the +Vs pin. For dual-supply operation, both the +Vs and the -Vs supplies should be bypassed to ground with separate  $0.1\mu F$  ceramic capacitors.  $2.2\mu F$  tantalum capacitor can be added for better performance.

The length of the current path is directly proportional to the magnitude of parasitic inductances and thus the high frequency impedance of the path. High speed currents in an inductive ground return create an unwanted voltage noise. Broad ground plane areas will reduce the parasitic inductance. Thus a ground plane layer is important for high speed circuit design.

## Typical Application Circuits

### Differential Amplifier

The circuit shown in Figure 4 performs the differential function. If the resistors ratios are equal ( $R_4 / R_3 = R_2 / R_1$ ), then  $V_{OUT} = (V_{IP} - V_{IN}) \times R_2 / R_1 + V_{REF}$ .

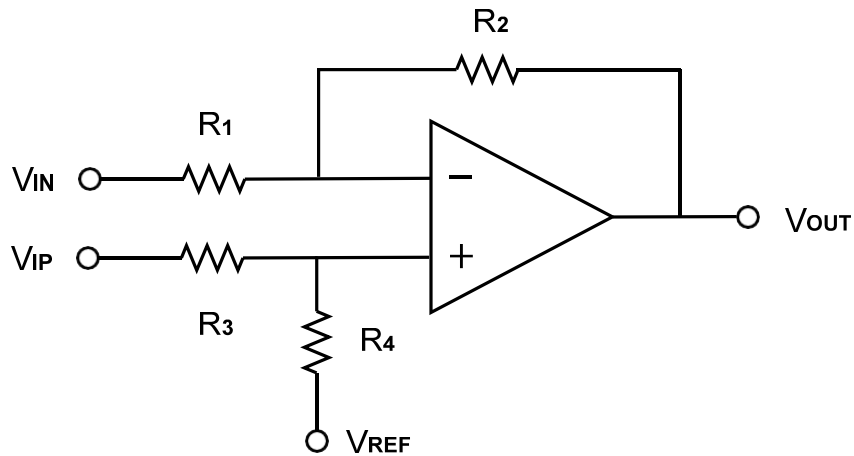

Figure 4. Differential Amplifier

**Low Pass Active Filter**

When receiving low-level signals, limiting the bandwidth of the incoming signals into the system is often required. The simplest way to establish this limited bandwidth is to place an RC filter at the noninverting terminal of the amplifier. If even more attenuation is needed, a multiple pole filter is required. The Sallen-Key filter can be used for this task, as Figure 5. For best results, the amplifier should have a bandwidth that is 8 to 10 times the filter frequency bandwidth. Failure to follow this guideline can result in reduction of phase margin. The large values of feedback resistors can couple with parasitic capacitance and cause undesired effects such as ringing or oscillation in high-speed amplifiers. Keep resistors value as low as possible and consistent with output loading consideration.

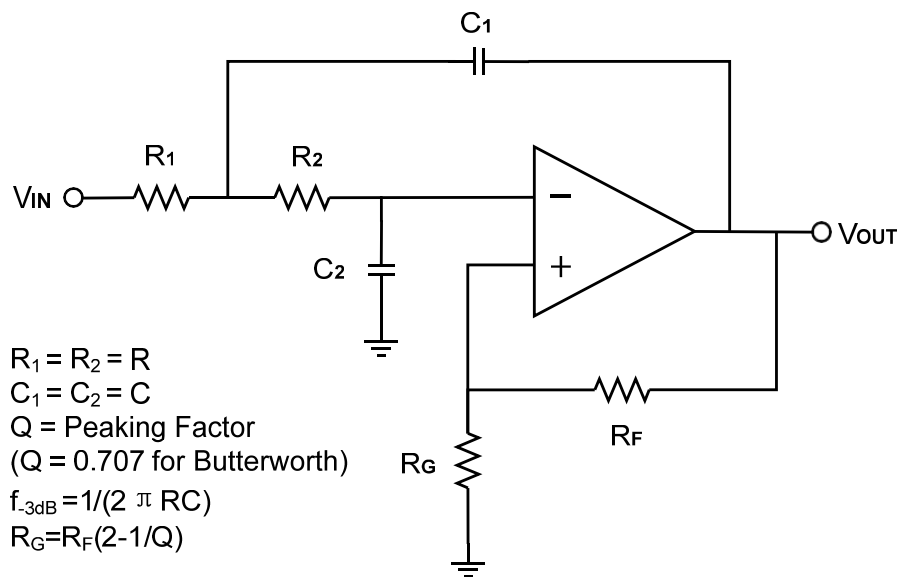
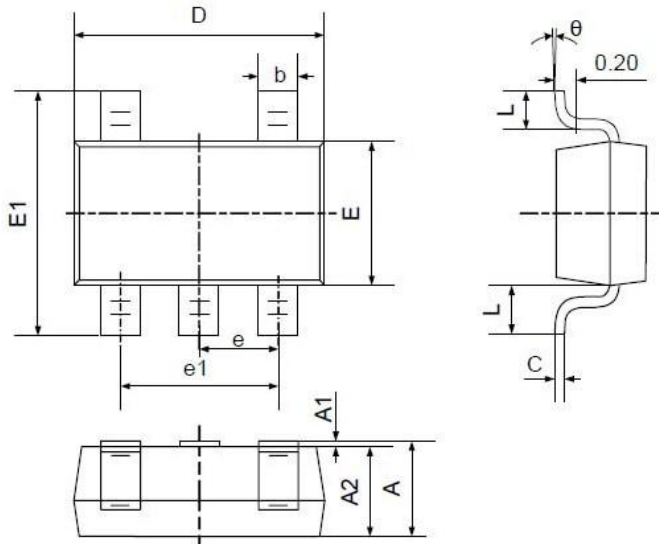

Figure 5. Two-Pole Low-Pass Sallen-Key Active Filter

## 5. Package Information

### 5.1 SOT23-5 (Package Outline Dimensions)



Symbol	Dimensions In Millimeters		Dimensions In Inches	
	Min	Max	Min	Max
A	1.050	1.250	0.041	0.049
A1	0.000	0.100	0.000	0.004
A2	1.050	1.150	0.041	0.045
b	0.300	0.400	0.012	0.016
c	0.100	0.200	0.004	0.008
D	2.820	3.020	0.111	0.119
E	1.500	1.700	0.059	0.067
E1	2.650	2.950	0.104	0.116
e	0.950TYP		0.037TYP	
e1	1.800	2.000	0.071	0.079
L	0.700REF		0.028REF	
L1	0.300	0.600	0.012	0.024
θ	0°	8°	0°	8°

### 5.2 SOP8 (Package Outline Dimensions)

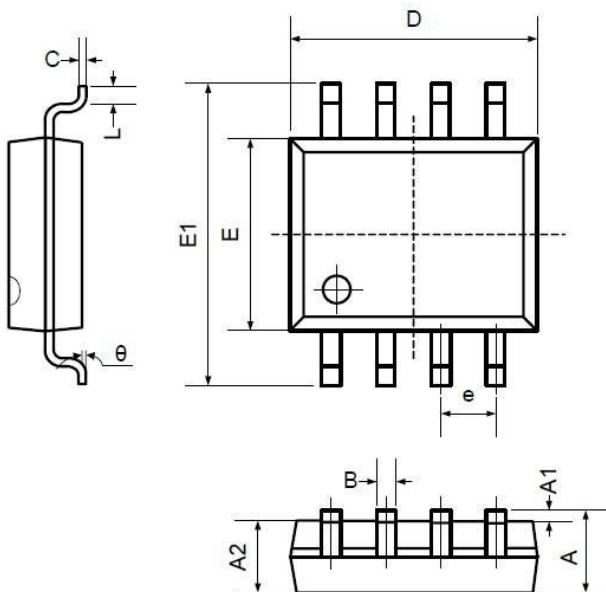

Symbol	Dimensions In Millimeters		Dimensions In Inches	
	Min	Max	Min	Max
A	1.350	1.750	0.053	0.069
A1	0.100	0.250	0.004	0.010
A2	1.350	1.550	0.053	0.061
B	0.330	0.510	0.013	0.020
C	0.190	0.250	0.007	0.010
D	4.780	5.000	0.188	0.197
E	3.800	4.000	0.150	0.157
E1	5.800	6.300	0.228	0.248
e	1.270TYP		0.050TYP	
L	0.400	1.270	0.016	0.050
θ	0°	8°	0°	8°

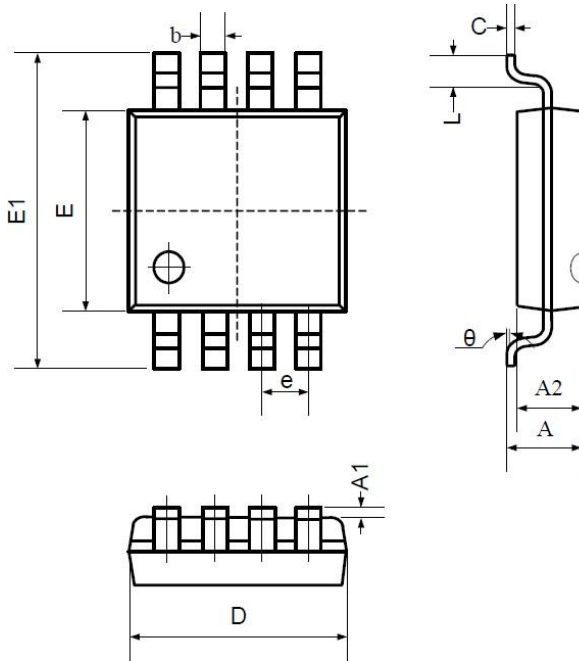

**5.3 MSOP8 (Package Outline Dimensions)**

Symbol	Dimensions In Millimeters		Dimensions In Inches	
	Min	Max	Min	Max
A	0.800	1.200	0.031	0.047
A1	0.000	0.200	0.000	0.008
A2	0.760	0.970	0.030	0.038
b	0.30 TYP		0.012 TYP	
c	0.15 TYP		0.006 TYP	
D	2.900	3.100	0.114	0.122
e	0.65 TYP		0.026 TYP	
E	2.900	3.100	0.114	0.122
E1	4.700	5.100	0.185	0.201
L	0.410	0.650	0.016	0.026
$\theta$	0°	6°	0°	6°

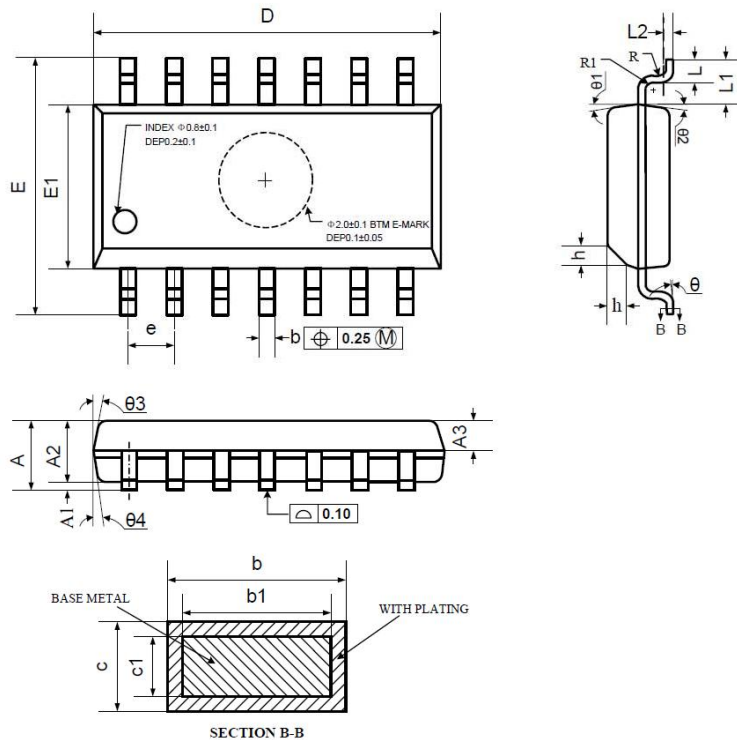
**5.4 SOP14 (Package Outline Dimensions)**

Symbol	Dimensions In Millimeters		
	MIN	NOM	MAX
A	1.35	1.60	1.75
A1	0.10	0.15	0.25
A2	1.25	1.45	1.65
A3	0.55	0.65	0.75
b	0.36		0.49
b1	0.35	0.40	0.45
c	0.16		0.25
c1	0.15	0.20	0.25
D	8.53	8.63	8.73
E	5.80	6.00	6.20
E1	3.80	3.90	4.00
e	1.27 BSC		
L	0.45	0.60	0.80
L1	1.04 REF		
L2	0.25 BSC		
R	0.07		
R1	0.07		
h	0.30	0.40	0.50
$\theta$	0°		8°
$\theta 1$	6°	8°	10°
$\theta 2$	6°	8°	10°
$\theta 3$	5°	7°	9°
$\theta 4$	5°	7°	9°

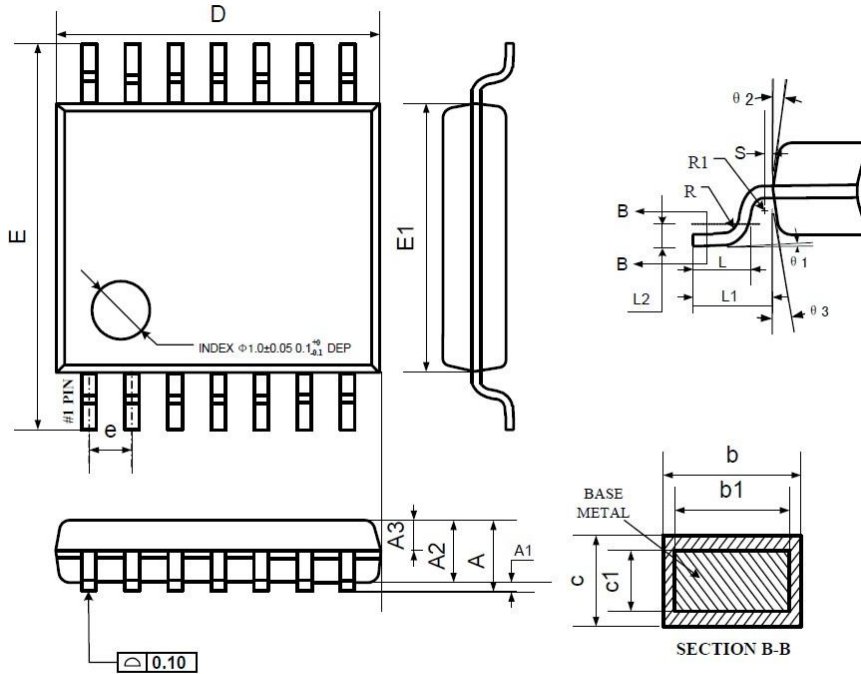
**5.5 TSSOP14 (Package Outline Dimensions)**

Symbol	Dimensions In Millimeters		
	MIN	NOM	MAX
A	—	—	1.20
A1	0.05	—	0.15
A2	0.90	1.00	1.05
A3	0.34	0.44	0.54
b	0.20	—	0.28
b1	0.20	0.22	0.24
c	0.10	—	0.19
c1	0.10	0.13	0.15
D	4.86	4.96	5.06
E	6.20	6.40	6.60
E1	4.30	4.40	4.50
e	0.65 BSC		
L	0.45	0.60	0.75
L1	1.00 REF		
L2	0.25 BSC		
R	0.09	—	—
R1	0.09	—	—
S	0.20	—	—
$\theta_1$	0°	—	8°
$\theta_2$	10°	12°	14°
$\theta_3$	10°	12°	14°

**6. Related Parts**

Part Number	Description
COS6041/2/4	24kHz, 0.5 $\mu$ A, RRIO Op Amps, 1.8 to 5.5V Supply
COS1347/2347/4347	350kHz, 15 $\mu$ A, RRIO Op Amps, 1.8 to 5.5V Supply
COS321/2/4	1.5MHz, 50 $\mu$ A, RRIO Op Amps, 1.8 to 5.5V Supply
COS1314/2314/4314	3MHz, 150 $\mu$ A, RRIO Op Amps, 1.8 to 5.5V Supply
COS821/2/4	5MHz, 300 $\mu$ A, RRIO Op Amps, 1.8 to 5.5V Supply
COS1374/2374/4374	7MHz, 500 $\mu$ A, RRIO Op Amps, 1.8 to 5.5V Supply
COS721/2/4	10MHz, 650 $\mu$ A, RRIO Op Amps, 2.1 to 5.5V Supply
COS1333/2333/4333	0.35MHz, 18 $\mu$ A, RRIO Op Amps, 1.8 to 5.5V Supply, Zero Drift, Vos<20 $\mu$ V
COS8551/2/4	1.5MHz, 55 $\mu$ A, RRIO Op Amps, 1.8 to 5.5V Supply, Zero Drift, Vos<10 $\mu$ V