

Rail-to-rail 0.9 V open-drain output, nanopower comparators

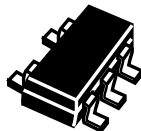

SC70-5



SOT23-5



MiniSO8



DFN8 2x2

Features

- Ultra low current consumption: 250 nA typ./op.
- Propagation delay: 2 μ s typ.
- Rail-to-rail inputs
- Open-drain outputs
- Supply operation from 0.9 V to 5.5 V
- Wide temperature range: -40 to +125 °C
- ESD tolerance: 8 kV HBM
- Single version available in SC70-5 and SOT23-5 package
- Dual version available in MiniSO8 and DFN8 2x2 mm package

Applications

- Portable systems
- Signal conditioning
- Medical

Description

The open-drain series of nanopower comparator integrates a single version [TS880](#) and a dual version [TS883](#). They feature an ultra low supply current of 250 nA typical per operator with rail-to-rail input capability and open-drain output. The performance of these comparators allows them to be used in a wide range of portable applications. The [TS880](#) and [TS883](#) minimize battery supply leakage and therefore enhance battery lifetime.

Operating from 0.9 to 5.5V supply voltage, these comparators can be used over a wide temperature range (-40 to +125 °C) keeping the current consumption at an ultra low level.

Product status link

[TS880, TS883](#)

Related products

[TS881](#)

[TS882](#)

[TS884](#)

See the datasheet for push-pull output version

1 Pin description

Figure 1. Pin connection TS880 (top view)

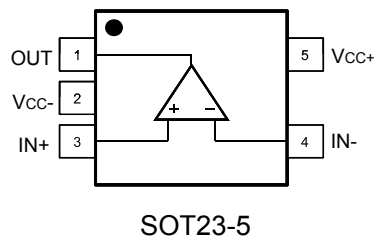
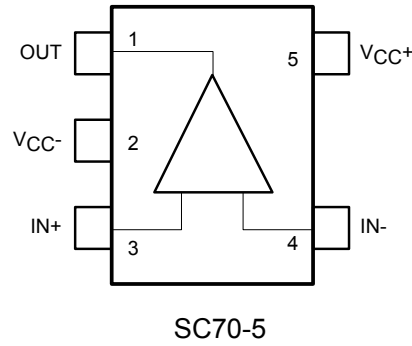
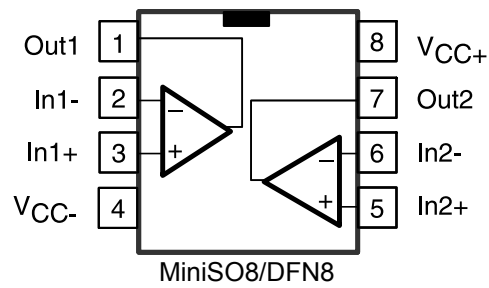

Figure 2. Pin connection TS883 (top view)



2 Absolute maximum ratings and operating conditions

Table 1. Absolute maximum ratings

Symbol	Parameter	Value	Unit
V_{CC}	Supply voltage ⁽¹⁾	6	V
V_{ID}	Differential input voltage ⁽²⁾	$\pm V_{CC}$	V
V_{IN}	Input voltage range	$(V_{CC-}) - 0.3$ to $(V_{CC+}) + 0.3$	V
I_{IN}	Input current ⁽³⁾	± 10	mA
V_{OUT}	Output voltage	6	V
R_{THJA}	Thermal resistance junction to ambient SC70-5	205	°C/W
	Thermal resistance junction to ambient SOT23-5	250	
	Thermal resistance junction to ambient MiniSO8	190	
	Thermal resistance junction to ambient DFN8 2x2 mm	57	
T_{STG}	Storage temperature	-65 to +150	°C
T_J	Junction temperature	150	°C
T_{LEAD}	Lead temperature (soldering 10 s)	260	°C
ESD	Human body model (HBM) ⁽⁴⁾	8000	V
	Charged device model (CDM) ⁽⁵⁾	1500	

1. All voltage values, except differential voltages, are referenced to V_{CC-} . V_{CC} is defined as the difference between V_{CC+} and V_{CC-} .
2. The magnitude of input and output voltages must never exceed the supply rail ± 0.3 V.
3. Input current must be limited by a serial resistor with inputs when the input voltage is beyond supply voltage.
4. According to JEDEC standard JESD22-A114F.
5. According to ANSI/ESD STM5.3.1.

Table 2. Operating conditions

Symbol	Parameter	Value	Unit
T_{oper}	Operating temperature range	-40 to +125	°C
V_{CC}	Supply voltage	0.9 to 5.5	V
V_{ICM}	Common mode input voltage range $0.9 < V_{CC} < 1.1$ V ⁽¹⁾	$(V_{CC-}) - 0.2$ to $(V_{CC-}) + 0.2$ and $(V_{CC+}) - 0.2$ to $(V_{CC+}) + 0.2$	V
	Common mode input voltage range $1.1 \leq V_{CC} < 5.5$ V	$(V_{CC-}) - 0.2$ to $(V_{CC+}) + 0.2$	
V_{OUT}	Output voltage	0 to 5.5	V

1. See Figure 13. Input offset voltage vs. input common mode voltage, $V_{CC}=0.9$ V, Figure 14. Input hysteresis voltage vs. input common mode voltage, $V_{CC}=0.9$ V, Figure 27. Propagation delay T_{PLH} vs. input common mode voltage, $V_{CC}=0.9$ V and Figure 28. Propagation delay T_{PHL} vs. input common mode voltage, $V_{CC}=0.9$ V.

3 Electrical characteristics

Table 3. Electrical characteristics $V_{CC} = +0.9\text{ V}$, $T_{amb} = 25\text{ °C}$, $V_{ICM} = 0\text{ V}$ (unless otherwise specified).

Symbol	Parameter	Test conditions	Min.	Typ.	Max.	Unit
V_{IO}	Input offset voltage ⁽¹⁾	$T_{amb} = +25\text{ °C}$	-10	1	10	mV
		$-40\text{ °C} < T_{amb} < +85\text{ °C}$	-12		12	
ΔV_{IO}	Input offset voltage drift	$-40\text{ °C} < T_{amb} < +85\text{ °C}$		3		$\mu\text{V}/\text{°C}$
V_{HYST}	Input hysteresis voltage ⁽²⁾	$T_{amb} = +25\text{ °C}$		2.6		mV
		$-40\text{ °C} < T_{amb} < +85\text{ °C}$	1		4.2	
I_{IO}	Input offset current ⁽³⁾	$T_{amb} = +25\text{ °C}$		1	10	pA
		$-40\text{ °C} < T_{amb} < +85\text{ °C}$			100	
I_{IB}	Input bias current ⁽³⁾	$T_{amb} = +25\text{ °C}$		5	10	pA
		$-40\text{ °C} < T_{amb} < +85\text{ °C}$			100	
I_{CC}	Supply current per operator	Output low, $V_{ID} = -0.1\text{ V}$		300	480	nA
		$-40\text{ °C} < T_{amb} < +85\text{ °C}$			500	
		Output high, $V_{ID} = +0.1\text{ V}$		250	410	
		$-40\text{ °C} < T_{amb} < +85\text{ °C}$			440	
I_{sink}	Output sink current	$V_{OUT} = V_{CC+}$, $V_{ID} = -0.1\text{ V}$		1.2		mA
I_{OH}	High level output current	$V_{OUT} = V_{CC+}$, $V_{ID} = 0.1\text{ V}$		17	30	pA
		$-40\text{ °C} < T_{amb} < +85\text{ °C}$			15	nA
V_{OL}	Output voltage low	$I_{sink} = 50\text{ }\mu\text{A}$, $V_{ID} = -0.1\text{ V}$		10	50	mV
		$-40\text{ °C} < T_{amb} < +85\text{ °C}$			70	
T_{PLH}	Propagation delay ⁽⁴⁾ (low to high)	$f = 1\text{ kHz}$, $C_L = 10\text{ pF}$, overdrive = 10 mV $V_{PU} = V_{CC+}$				μs
		$R_{PU} = 10\text{ k}\Omega$, $T_{amb} = +25\text{ °C}$		7	10	
		$R_{PU} = 10\text{ k}\Omega$, $40\text{ °C} < T_{amb} < +85\text{ °C}$			12	
		$R_{PU} = 1\text{ M}\Omega$, $T_{amb} = +25\text{ °C}$		20	22	
		$R_{PU} = 1\text{ M}\Omega$, $-40\text{ °C} < T_{amb} < +85\text{ °C}$			24	
		$f = 1\text{ kHz}$, $C_L = 10\text{ pF}$, overdrive = 100 mV $V_{PU} = V_{CC+}$				
		$R_{PU} = 10\text{ k}\Omega$, $T_{amb} = +25\text{ °C}$		2.5	4	
		$R_{PU} = 10\text{ k}\Omega$, $40\text{ °C} < T_{amb} < +85\text{ °C}$			4.5	
		$R_{PU} = 1\text{ M}\Omega$, $T_{amb} = +25\text{ °C}$		18	20	
		$R_{PU} = 1\text{ M}\Omega$, $-40\text{ °C} < T_{amb} < +85\text{ °C}$			21	

Symbol	Parameter	Test conditions	Min.	Typ.	Max.	Unit	
T _{PHL}	Propagation delay ⁽⁵⁾ (high to low)	f = 1 kHz, C _L = 10 pF, overdrive = 10 mV V _{PU} = V _{CC+}				μs	
		R _{PU} = 10 kΩ, T _{amb} = +25 °C		6	9		
		R _{PU} = 10 kΩ, 40 °C < T _{amb} < +85 °C			10		
		R _{PU} = 1 MΩ, T _{amb} = +25 °C		7	9		
		R _{PU} = 1 MΩ, -40 °C < T _{amb} < +85 °C			10		
		f = 1 kHz, C _L = 10 pF, overdrive = 100 mV V _{PU} = V _{CC+}					
		R _{PU} = 10 kΩ, T _{amb} = +25 °C		2	3.5		
		R _{PU} = 10 kΩ, 40 °C < T _{amb} < +85 °C			4		
		R _{PU} = 1 MΩ, T _{amb} = +25 °C		2	4		
		R _{PU} = 1 MΩ, -40 °C < T _{amb} < +85 °C			5		
T _R	Rise time (10% to 90%)	C _L = 10 pF, R _{PU} = 10 kΩ, overdrive = 100 mV		500		ns	
T _F	Fall time (90% to 10%)	C _L = 10 pF, R _{PU} = 10 kΩ, overdrive = 100 mV		600		ns	
T _{ON}	Power-up time			0.9	1.3	ms	

1. The offset is defined as the average value of positive and negative trip points (input voltage differences requested to change the output state in each direction).
2. The hysteresis is a built-in feature. It is defined as the voltage difference between the trip points.
3. Maximum values include unavoidable inaccuracies of the industrial tests.
4. T_{PLH} is measured when the output signal crosses a voltage level at 50% of V_{CC} with the following conditions: inverting input voltage (IN-) = V_{ICM} and non-inverting input voltage (IN+) moving from V_{ICM} - 100 mV to V_{ICM} + overdrive.
5. T_{PHL} is measured when the output signal crosses a voltage level at 50% of V_{CC} with the following conditions: inverting input voltage (IN-) = V_{ICM} and non-inverting input voltage (IN+) moving from V_{ICM} + 100 mV to V_{ICM} - overdrive

Note: All values over the temperature range are guaranteed through correlation and simulation. No production test is performed at the temperature range limits.

Table 4. Electrical characteristics $V_{CC} = +1.2\text{ V}$, $T_{amb} = 25\text{ °C}$, $V_{ICM} = V_{CC}/2$ (unless otherwise specified).

Symbol	Parameter	Test conditions	Min.	Typ.	Max.	Unit
V_{IO}	Input offset voltage ⁽¹⁾	$T_{amb} = +25\text{ °C}$	-5	1	5	mV
		$-40\text{ °C} < T_{amb} < +125\text{ °C}$	-6		6	
ΔV_{IO}	Input offset voltage drift	$-40\text{ °C} < T_{amb} < +125\text{ °C}$		3		$\mu\text{V}/\text{°C}$
V_{HYST}	Input hysteresis voltage ⁽²⁾	$T_{amb} = +25\text{ °C}$		2.5		mV
		$-40\text{ °C} < T_{amb} < +125\text{ °C}$	1.6		4.2	
I_{IO}	Input offset current ⁽³⁾	$T_{amb} = +25\text{ °C}$		2	10	pA
		$-40\text{ °C} < T_{amb} < +125\text{ °C}$			100	
I_{IB}	Input bias current ⁽³⁾	$T_{amb} = +25\text{ °C}$		1	10	pA
		$-40\text{ °C} < T_{amb} < +125\text{ °C}$			100	
I_{CC}	Supply current per operator	Output low, $V_{ID} = -0.1\text{ V}$		320	490	nA
		$-40\text{ °C} < T_{amb} < +125\text{ °C}$			510	
		Output high, $V_{ID} = +0.1\text{ V}$		240	360	
		$-40\text{ °C} < T_{amb} < +125\text{ °C}$			390	
I_{sink}	Output sink current	$V_{OUT} = V_{CC+}$, $V_{ID} = -0.1\text{ V}$		3.6		mA
I_{OH}	High level output current	$V_{OUT} = V_{CC+}$, $V_{ID} = 0.1\text{ V}$		22	36	pA
		$-40\text{ °C} < T_{amb} < +125\text{ °C}$			15	nA
V_{OL}	Output voltage low	$I_{sink} = 0.2\text{ mA}$		25	50	mV
		$-40\text{ °C} < T_{amb} < +125\text{ °C}$			70	
CMRR	Common mode rejection ratio	$0 < V_{ICM} < V_{CC}$		68		dB
		$-40\text{ °C} < T_{amb} < +125\text{ °C}$	50			
T_{PLH}	Propagation delay (low to high)	$f = 1\text{ kHz}$, $C_L = 10\text{ pF}$, overdrive = 10 mV $V_{PU} = V_{CC+}$				μs
		$R_{PU} = 10\text{ k}\Omega$, $T_{amb} = +25\text{ °C}$		5	7	
		$R_{PU} = 10\text{ k}\Omega$, $40\text{ °C} < T_{amb} < +85\text{ °C}$			8	
		$R_{PU} = 1\text{ M}\Omega$, $T_{amb} = +25\text{ °C}$		20	21	
		$R_{PU} = 1\text{ M}\Omega$, $-40\text{ °C} < T_{amb} < +85\text{ °C}$			22	
		$f = 1\text{ kHz}$, $C_L = 10\text{ pF}$, overdrive = 100 mV $V_{PU} = V_{CC+}$				
		$R_{PU} = 10\text{ k}\Omega$, $T_{amb} = +25\text{ °C}$		1.9	3	
		$R_{PU} = 10\text{ k}\Omega$, $40\text{ °C} < T_{amb} < +85\text{ °C}$			3.5	
		$R_{PU} = 1\text{ M}\Omega$, $T_{amb} = +25\text{ °C}$		17	18	
$R_{PU} = 1\text{ M}\Omega$, $-40\text{ °C} < T_{amb} < +85\text{ °C}$			19			

Symbol	Parameter	Test conditions	Min.	Typ.	Max.	Unit	
T _{PHL}	Propagation delay ⁽⁵⁾ (high to low)	f = 1 kHz, C _L = 10 pF, overdrive = 10 mV V _{PU} = V _{CC+}				μs	
		R _{PU} = 10 kΩ, T _{amb} = + 25 °C		5	6		
		R _{PU} = 10 kΩ, 40 °C < T _{amb} < + 85 °C			7		
		R _{PU} = 1 MΩ, T _{amb} = + 25 °C		5	6		
		R _{PU} = 1 MΩ, -40 °C < T _{amb} < + 85 °C			7		
		f = 1 kHz, C _L = 10 pF, overdrive = 100 mV, V _{PU} = V _{CC+}					
		R _{PU} = 10 kΩ, T _{amb} = + 25 °C		1.7	2.5		
		R _{PU} = 10 kΩ, 40 °C < T _{amb} < + 85 °C			3		
		R _{PU} = 1 MΩ, T _{amb} = + 25 °C		2	3		
		R _{PU} = 1 MΩ, -40 °C < T _{amb} < + 85 °C			4		
T _R	Rise time (10% to 90%)	C _L = 10 pF, R _{PU} = 10 kΩ overdrive = 100 mV		800		ns	
T _F	Fall time (90% to 10%)	C _L = 10 pF, R _{PU} = 10 kΩ overdrive = 100 mV		250		ns	
T _{ON}	Power-up time			0.9	1.3	ms	

1. The offset is defined as the average value of positive and negative trip points (input voltage differences requested to change the output state in each direction)
2. The hysteresis is a built-in feature. It is defined as the voltage difference between the trip points.
3. Maximum values include unavoidable inaccuracies of the industrial tests.
4. T_{PLH} is measured when the output signal crosses a voltage level at 50% of V_{CC} with the following conditions: inverting input voltage (IN-) = V_{ICM} and non-inverting input voltage (IN+) moving from V_{ICM} - 100 mV to V_{ICM} + overdrive.
5. T_{PHL} is measured when the output signal crosses a voltage level at 50% of V_{CC} with the following conditions: inverting input voltage (IN-) = V_{ICM} and non-inverting input voltage (IN+) moving from V_{ICM} + 100 mV to V_{ICM} - overdrive.

Note: All values over the temperature range are guaranteed through correlation and simulation. No production test is performed at the temperature range limits.

Table 5. Electrical characteristics $V_{CC} = +2.7\text{ V}$, $T_{amb} = 25\text{ }^{\circ}\text{C}$, $V_{ICM} = V_{CC}/2$ (unless otherwise specified).

Symbol	Parameter	Test conditions	Min.	Typ.	Max.	Unit
V_{IO}	Input offset voltage	$T_{amb} = +25\text{ }^{\circ}\text{C}$	-5	1	5	mV
		$-40\text{ }^{\circ}\text{C} < T_{amb} < +125\text{ }^{\circ}\text{C}$	-6		6	
ΔV_{IO}	Input offset voltage drift	$-40\text{ }^{\circ}\text{C} < T_{amb} < +125\text{ }^{\circ}\text{C}$		3		$\mu\text{V}/^{\circ}\text{C}$
V_{HYST}	Input hysteresis voltage	$T_{amb} = +25\text{ }^{\circ}\text{C}$		2.7		mV
		$-40\text{ }^{\circ}\text{C} < T_{amb} < +125\text{ }^{\circ}\text{C}$	1.6		4.2	
I_{IO}	Input offset current ⁽³⁾	$T_{amb} = +25\text{ }^{\circ}\text{C}$		1	10	pA
		$-40\text{ }^{\circ}\text{C} < T_{amb} < +125\text{ }^{\circ}\text{C}$			100	
I_{IB}	Input bias current ⁽³⁾	$T_{amb} = +25\text{ }^{\circ}\text{C}$		5	10	pA
		$-40\text{ }^{\circ}\text{C} < T_{amb} < +125\text{ }^{\circ}\text{C}$			100	
I_{CC}	Supply current per operator	Output low, $V_{ID} = -0.1\text{ V}$		350	520	nA
		$-40\text{ }^{\circ}\text{C} < T_{amb} < +125\text{ }^{\circ}\text{C}$			540	
		Output high, $V_{ID} = +0.1\text{ V}$		250	370	
		$-40\text{ }^{\circ}\text{C} < T_{amb} < +125\text{ }^{\circ}\text{C}$			400	
I_{SINK}	Output sink current	$V_{OUT} = V_{CC+}$, $V_{ID} = -0.1\text{ V}$		22		mA
I_{OH}	High level output current	$V_{OUT} = V_{CC+}$, $V_{ID} = 0.1\text{ V}$		40	60	pA
		$-40\text{ }^{\circ}\text{C} < T_{amb} < +125\text{ }^{\circ}\text{C}$			18	nA
V_{OL}	Output voltage low	$I_{SINK} = 2\text{ mA}$		140	220	mV
		$-40\text{ }^{\circ}\text{C} < T_{amb} < +125\text{ }^{\circ}\text{C}$			290	
CMRR	Common mode rejection ratio	$0 < V_{ICM} < V_{CC}$		74		dB
		$-40\text{ }^{\circ}\text{C} < T_{amb} < +125\text{ }^{\circ}\text{C}$	55			
T_{PLH}	Propagation delay (low to high)	$f = 1\text{ kHz}$, $C_L = 10\text{ pF}$, overdrive = 10 mV $V_{PU} = V_{CC+}$				μs
		$R_{PU} = 10\text{ k}\Omega$, $T_{amb} = +25\text{ }^{\circ}\text{C}$		5.8	8	
		$R_{PU} = 10\text{ k}\Omega$, $40\text{ }^{\circ}\text{C} < T_{amb} < +85\text{ }^{\circ}\text{C}$			10	
		$R_{PU} = 1\text{ M}\Omega$, $T_{amb} = +25\text{ }^{\circ}\text{C}$		21	23	
		$R_{PU} = 1\text{ M}\Omega$, $-40\text{ }^{\circ}\text{C} < T_{amb} < +85\text{ }^{\circ}\text{C}$			24	
		$f = 1\text{ kHz}$, $C_L = 10\text{ pF}$, overdrive = 100 mV $V_{PU} = V_{CC+}$				
		$R_{PU} = 10\text{ k}\Omega$, $T_{amb} = +25\text{ }^{\circ}\text{C}$		2	3	
		$R_{PU} = 10\text{ k}\Omega$, $40\text{ }^{\circ}\text{C} < T_{amb} < +85\text{ }^{\circ}\text{C}$			3.5	
		$R_{PU} = 1\text{ M}\Omega$, $T_{amb} = +25\text{ }^{\circ}\text{C}$		18	19	
		$R_{PU} = 1\text{ M}\Omega$, $-40\text{ }^{\circ}\text{C} < T_{amb} < +85\text{ }^{\circ}\text{C}$			20	

Symbol	Parameter	Test conditions	Min.	Typ.	Max.	Unit	
T _{PHL}	Propagation delay (high to low)	f = 1 kHz, C _L = 10 pF, overdrive = 10 mV V _{PU} = V _{CC+}				μs	
		R _{PU} = 10 kΩ, T _{amb} = +25 °C		5.8	7		
		R _{PU} = 10 kΩ, 40 °C < T _{amb} < +85 °C			10		
		R _{PU} = 1 MΩ, T _{amb} = +25 °C		6	7		
		R _{PU} = 1 MΩ, -40 °C < T _{amb} < +85 °C			10		
		f = 1 kHz, C _L = 10 pF, overdrive = 100 mV V _{PU} = V _{CC+}					
		R _{PU} = 10 kΩ, T _{amb} = +25 °C		1.9	3		
		R _{PU} = 10 kΩ, 40 °C < T _{amb} < +85 °C			3.5		
		R _{PU} = 1 MΩ, T _{amb} = +25 °C		2	3.5		
		R _{PU} = 1 MΩ, -40 °C < T _{amb} < +85 °C			4.5		
T _R	Rise time (10% to 90%)	C _L = 10 pF, R _{PU} = 10 kΩ overdrive = 100 mV		1800		ns	
T _F	Fall time (90% to 10%)	C _L = 10 pF, R _{PU} = 10 kΩ overdrive = 100 mV		170		ns	
T _{ON}	Power-up time			0.9	1.3	ms	

1. The offset is defined as the average value of positive and negative trip points (input voltage differences requested to change the output state in each direction)
2. The hysteresis is a built-in feature. It is defined as the voltage difference between the trip points.
3. Maximum values include unavoidable inaccuracies of the industrial tests.
4. T_{PLH} is measured when the output signal crosses a voltage level at 50% of V_{CC} with the following conditions: inverting input voltage (IN-) = V_{ICM} and non-inverting input voltage (IN+) moving from V_{ICM} - 100 mV to V_{ICM} + overdrive.
5. T_{PHL} is measured when the output signal crosses a voltage level at 50% of V_{CC} with the following conditions: inverting input voltage (IN-) = V_{ICM} and non-inverting input voltage (IN+) moving from V_{ICM} + 100 mV to V_{ICM} - overdrive.

Note: All values over the temperature range are guaranteed through correlation and simulation. No production test is performed at the temperature range limits.

Table 6. Electrical characteristics $V_{CC} = +5\text{ V}$, $T_{amb} = 25\text{ °C}$, $V_{ICM} = V_{CC}/2$ (unless otherwise specified).

Symbol	Parameter	Test conditions	Min.	Typ.	Max.	Unit
V_{IO}	Input offset voltage	$T_{amb} = +25\text{ °C}$	-5	1	5	mV
		$-40\text{ °C} < T_{amb} < +125\text{ °C}$	-6		6	
ΔV_{IO}	Input offset voltage drift	$-40\text{ °C} < T_{amb} < +125\text{ °C}$		3		$\mu\text{V}/\text{°C}$
V_{HYST}	Input hysteresis voltage (2)	$T_{amb} = +25\text{ °C}$		3.1		mV
		$-40\text{ °C} < T_{amb} < +125\text{ °C}$	1.6		4.2	
I_{IO}	Input offset current (3)	$T_{amb} = +25\text{ °C}$		1	10	pA
		$-40\text{ °C} < T_{amb} < +125\text{ °C}$			100	
I_{IB}	Input bias current (3)	$T_{amb} = +25\text{ °C}$		10	20	pA
		$-40\text{ °C} < T_{amb} < +125\text{ °C}$			100	
I_{CC}	Supply current per operator	Output low, $V_{ID} = -0.1\text{ V}$		400	600	nA
		$-40\text{ °C} < T_{amb} < +125\text{ °C}$			630	
		Output high, $V_{ID} = +0.1\text{ V}$		290	430	
		$-40\text{ °C} < T_{amb} < +125\text{ °C}$			480	
I_{SINK}	Output sink current	$V_{OUT} = V_{CC+}$, $V_{ID} = -0.1\text{ V}$		50		mA
I_{OH}	High level output current	$V_{OUT} = V_{CC+}$, $V_{ID} = 0.1\text{ V}$		80	100	pA
		$-40\text{ °C} < T_{amb} < +125\text{ °C}$			20	nA
V_{OL}	Output voltage low	$I_{SINK} = 2\text{ mA}$		110	180	mV
		$-40\text{ °C} < T_{amb} < +125\text{ °C}$			240	
CMRR	Common mode rejection ratio	$0 < V_{ICM} < V_{CC}$		78		dB
		$-40\text{ °C} < T_{amb} < +125\text{ °C}$	55			
SVR	Supply voltage rejection	$\Delta V_{CC} = 1.2\text{ V to }5\text{ V}$		80		dB
		$-40\text{ °C} < T_{amb} < +125\text{ °C}$	65			
T_{PLH}	Propagation delay (4) (low to high)	$f = 1\text{ kHz}$, $C_L = 10\text{ pF}$, overdrive = 10 mV $V_{PU} = V_{CC+}$				μs
		$R_{PU} = 10\text{ k}\Omega$, $T_{amb} = +25\text{ °C}$		7	9	
		$R_{PU} = 10\text{ k}\Omega$, $40\text{ °C} < T_{amb} < +85\text{ °C}$			13	
		$R_{PU} = 1\text{ M}\Omega$, $T_{amb} = +25\text{ °C}$		21	23	
		$R_{PU} = 1\text{ M}\Omega$, $-40\text{ °C} < T_{amb} < +85\text{ °C}$			24	
		$f = 1\text{ kHz}$, $C_L = 10\text{ pF}$, overdrive = 100 mV $V_{PU} = V_{CC+}$				
		$R_{PU} = 10\text{ k}\Omega$, $T_{amb} = +25\text{ °C}$		3	4	
		$R_{PU} = 10\text{ k}\Omega$, $40\text{ °C} < T_{amb} < +85\text{ °C}$			5	
		$R_{PU} = 1\text{ M}\Omega$, $T_{amb} = +25\text{ °C}$		18	20	
$R_{PU} = 1\text{ M}\Omega$, $-40\text{ °C} < T_{amb} < +85\text{ °C}$			21			

Symbol	Parameter	Test conditions	Min.	Typ.	Max.	Unit
T _{PHL}	Propagation delay ⁽⁵⁾ (high to low)	f = 1 kHz, C _L = 10 pF, overdrive = 10 mV V _{PU} = V _{CC+}				μs
		R _{PU} = 10 kΩ, T _{amb} = +25 °C		7.5	9	
		R _{PU} = 10 kΩ, 40 °C < T _{amb} < +85 °C			12	
		R _{PU} = 1 MΩ, T _{amb} = +25 °C		9	11	
		R _{PU} = 1 MΩ, -40 °C < T _{amb} < +85 °C			13	
		f = 1 kHz, C _L = 10 pF, overdrive = 100 mV V _{PU} = V _{CC+}				
		R _{PU} = 10 kΩ, T _{amb} = +25 °C		2	3	
		R _{PU} = 10 kΩ, 40 °C < T _{amb} < +85 °C			3.5	
		R _{PU} = 1 MΩ, T _{amb} = +25 °C		2	3	
		R _{PU} = 1 MΩ, -40 °C < T _{amb} < +85 °C			4	
T _R	Rise time (10% to 90%)	C _L = 10 pF, R _{PU} = 10 kΩ overdrive = 100 mV		3.7		μs
T _F	Fall time (90% to 10%)	C _L = 10 pF, R _{PU} = 10 kΩ overdrive = 100 mV		190		ns
T _{ON}	Power-up time			0.9	1.3	ms

1. The offset is defined as the average value of positive and negative trip points (input voltage differences requested to change the output state in each direction).
2. The hysteresis is a built-in feature. It is defined as the voltage difference between the trip points.
3. Maximum values include unavoidable inaccuracies of the industrial tests
4. T_{PLH} is measured when the output signal crosses a voltage level at 50% of V_{CC} with the following conditions: inverting input voltage (IN-) = V_{ICM} and non-inverting input voltage (IN+) moving from V_{ICM} - 100 mV to V_{ICM} + overdrive.
5. T_{PHL} is measured when the output signal crosses a voltage level at 50% of V_{CC} with the following conditions: inverting input voltage (IN-) = V_{ICM} and non-inverting input voltage (IN+) moving from V_{ICM} + 100 mV to V_{ICM} - overdrive.

Note: All values over the temperature range are guaranteed through correlation and simulation. No production test is performed at the temperature range limits.

4 Typical characteristics and curves

Figure 3. Current consumption vs. supply voltage, $V_{icm}=V_{cc}$, output low

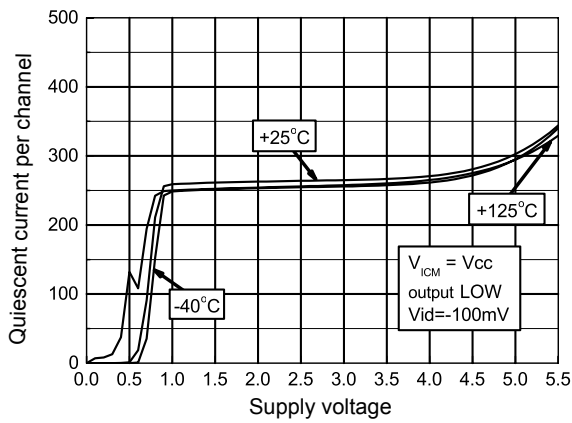

Figure 4. Current consumption vs. supply voltage, $V_{icm}=V_{cc}$, output high

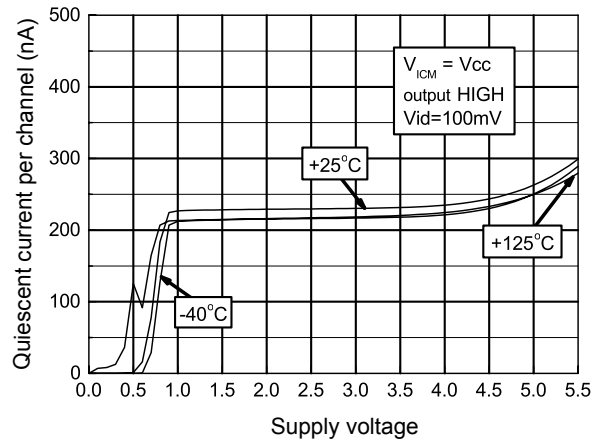

Figure 5. Current consumption vs. supply voltage, $V_{icm}=0V$, output low

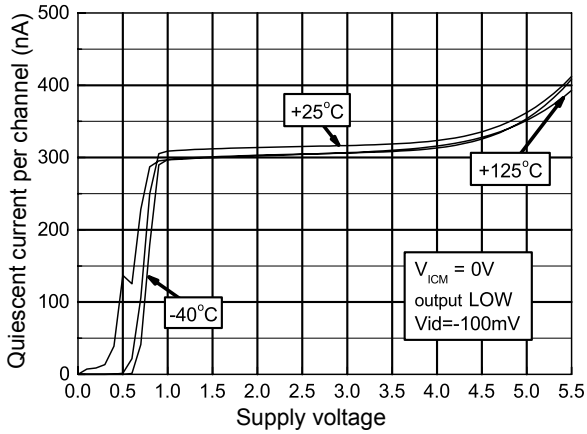

Figure 6. Current consumption vs. supply voltage, $V_{icm}=0V$, output high

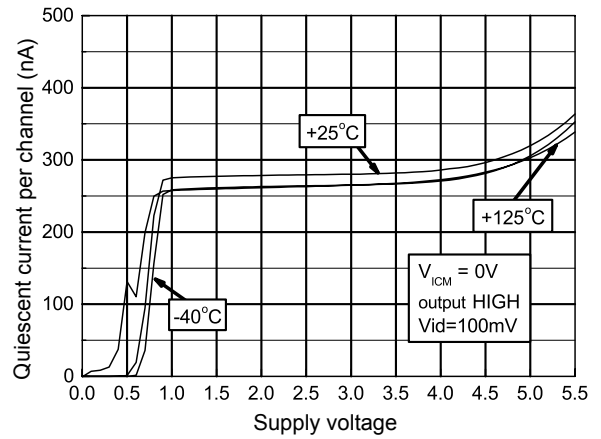

Figure 7. Current consumption vs. input common mode voltage, $V_{cc}=0.9\text{ V}$, output low

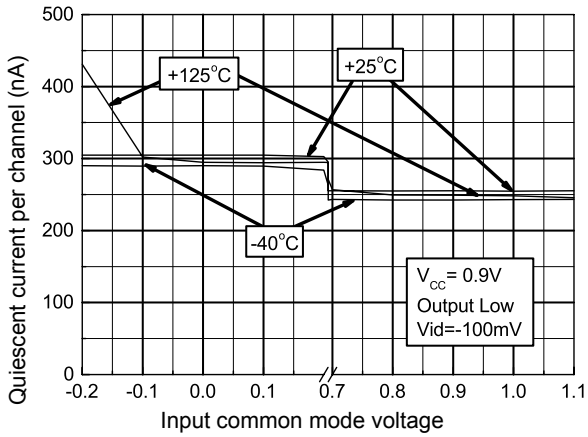

Figure 8. Current consumption vs. input common mode voltage, $V_{cc}=0.9\text{ V}$, output high

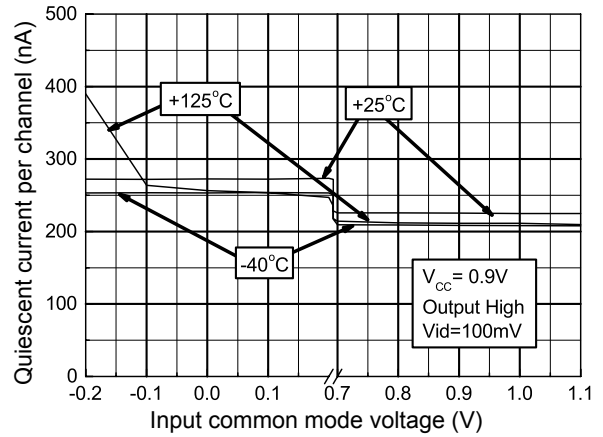

Figure 9. Current consumption vs. input common mode voltage, $V_{cc}=5\text{ V}$, output low

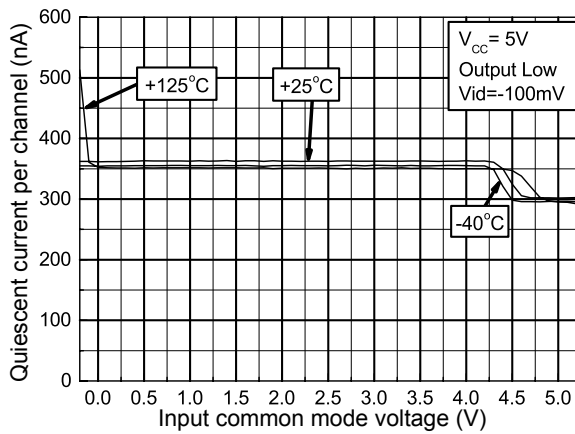

Figure 10. Current consumption vs. input common mode voltage, $V_{cc}=5\text{ V}$, output high

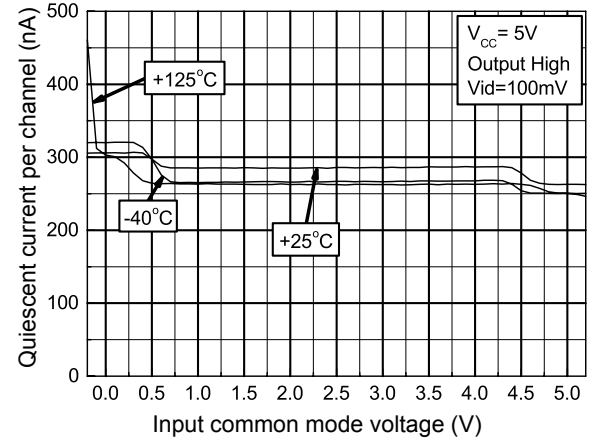

Figure 11. Current consumption vs. temperature

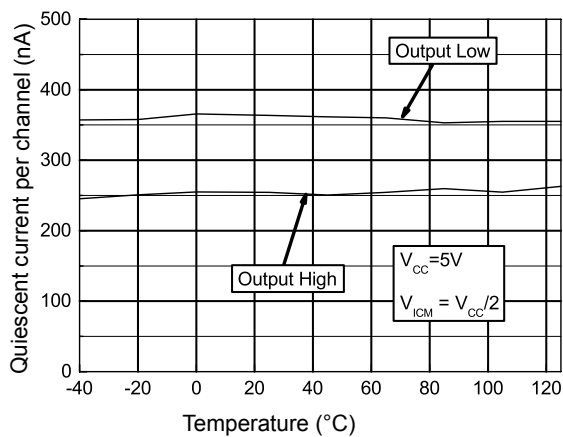

Figure 12. Current consumption vs. toggle frequency

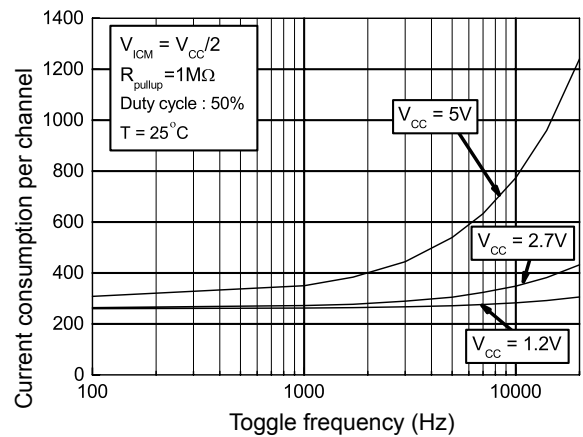

Figure 13. Input offset voltage vs. input common mode voltage, $V_{cc}=0.9\text{ V}$

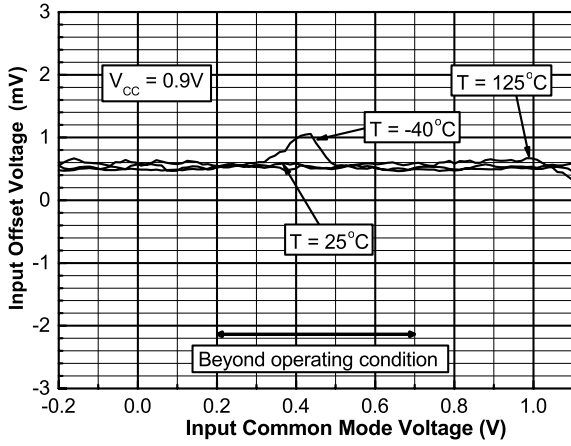

Figure 14. Input hysteresis voltage vs. input common mode voltage, $V_{cc}=0.9\text{ V}$

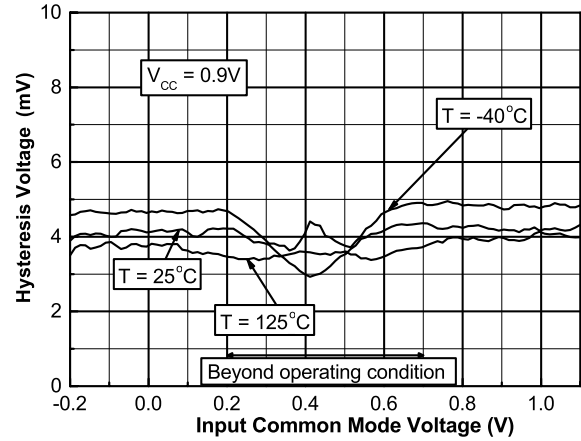

Figure 15. Input offset voltage vs. input common mode voltage, $V_{cc}=1.2\text{ V}$

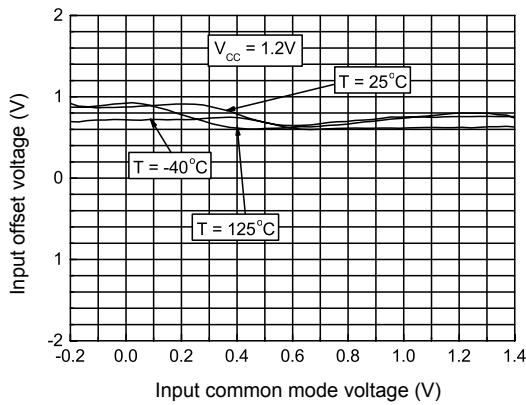

Figure 16. Input hysteresis voltage vs. input common mode voltage, $V_{cc}=1.2\text{ V}$

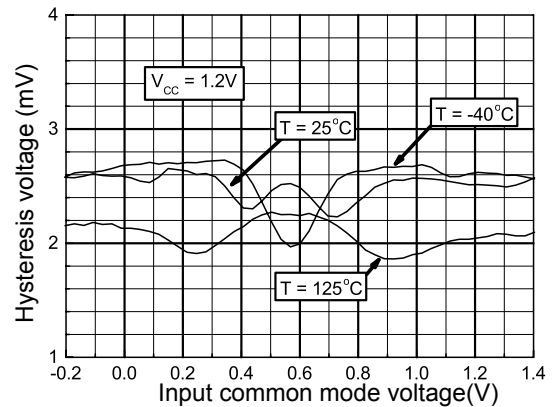

Figure 17. Input offset voltage vs. input common mode voltage, $V_{cc}=5\text{ V}$

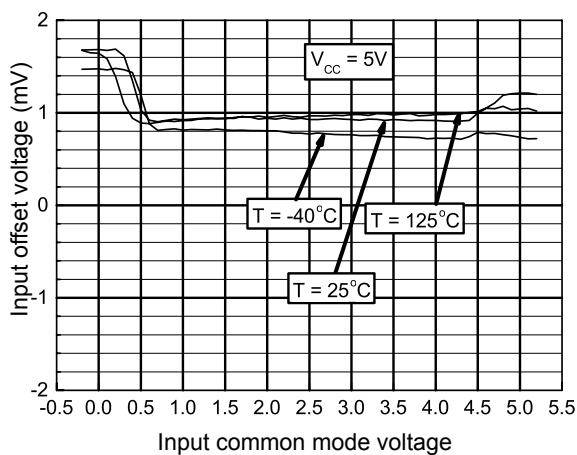

Figure 18. Input hysteresis voltage vs. input common mode voltage, $V_{cc}=5\text{ V}$

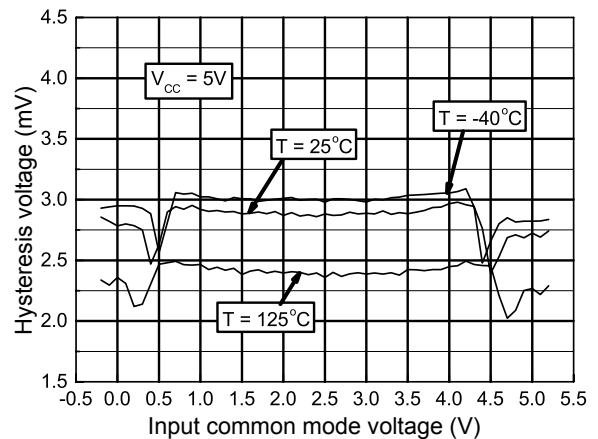

Figure 19. Input offset voltage vs. temperature

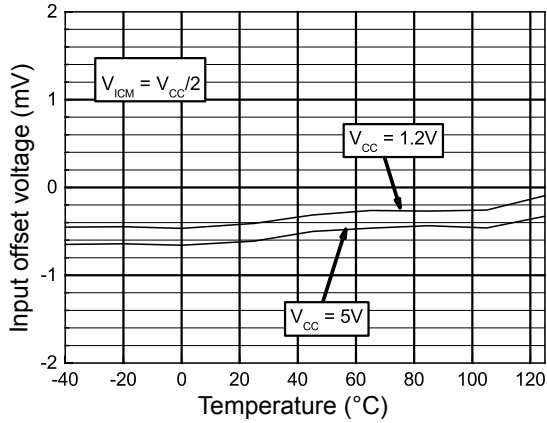

Figure 20. Input hysteresis voltage vs. temperature

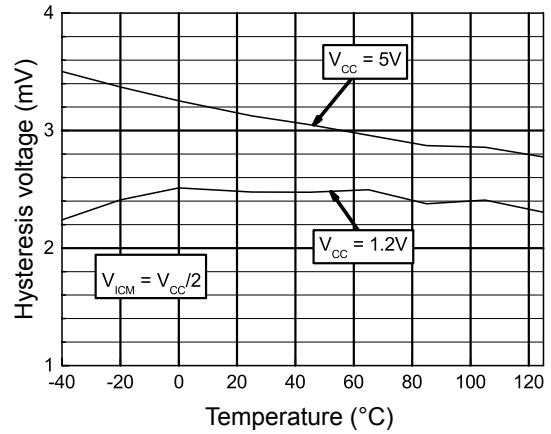

Figure 21. Output voltage drop vs. sink current, $V_{CC}=1.2V$

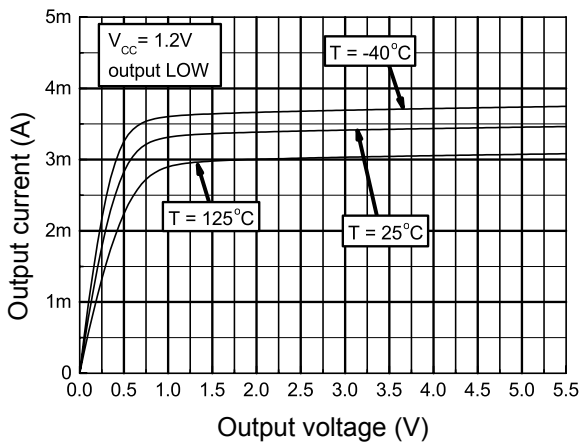

Figure 22. Output voltage drop vs. source current, $V_{CC}=1.2V$

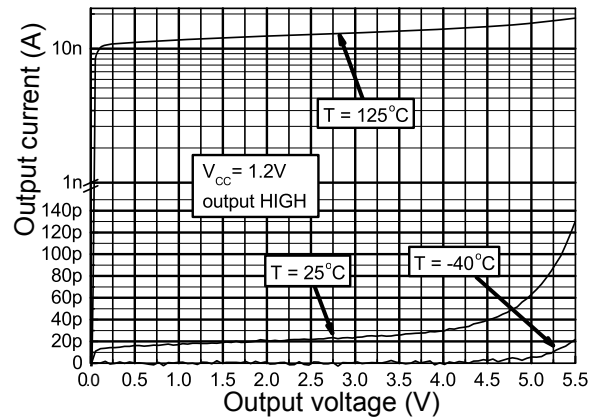

Figure 23. Output voltage drop vs. sink current, $V_{CC}=2.7V$

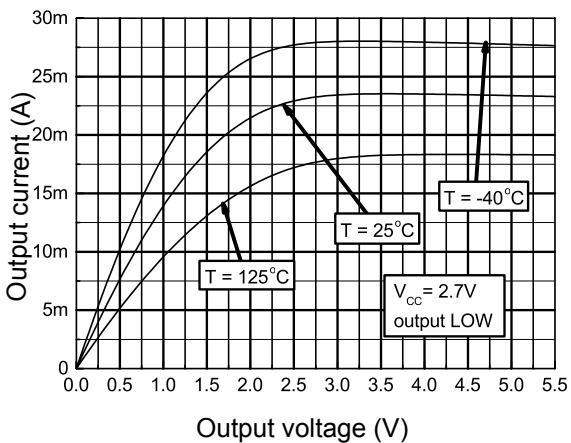

Figure 24. Output voltage drop vs. source current, $V_{CC}=2.7V$

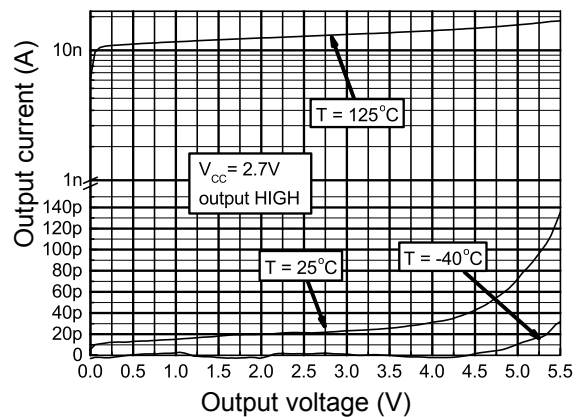

Figure 25. Output voltage drop vs. sink current, $V_{CC}=5\text{ V}$

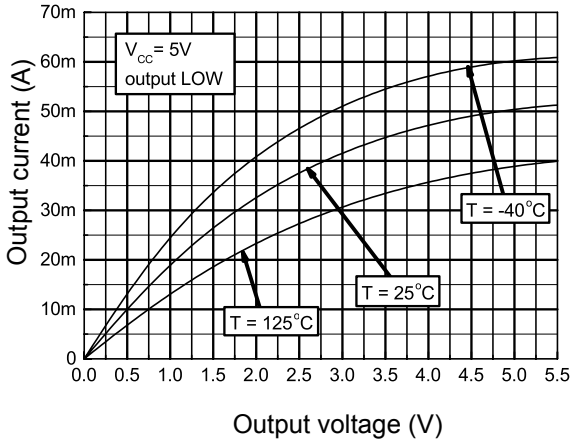

Figure 26. Output voltage drop vs. source current, $V_{CC}=5\text{ V}$

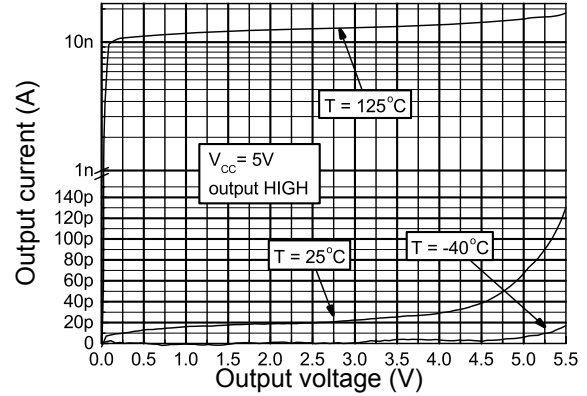

Figure 27. Propagation delay T_{PLH} vs. input common mode voltage, $V_{CC}=0.9\text{ V}$

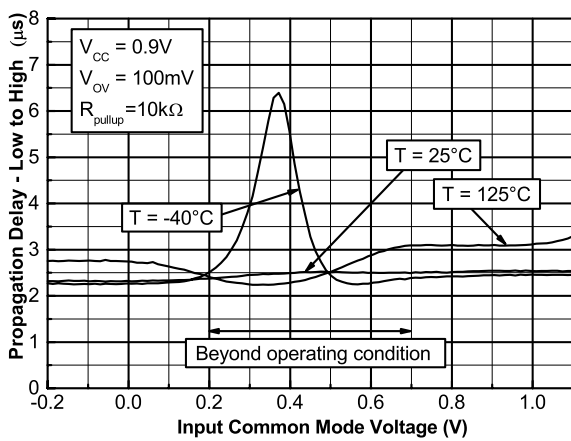

Figure 28. Propagation delay T_{PHL} vs. input common mode voltage, $V_{CC}=0.9\text{ V}$

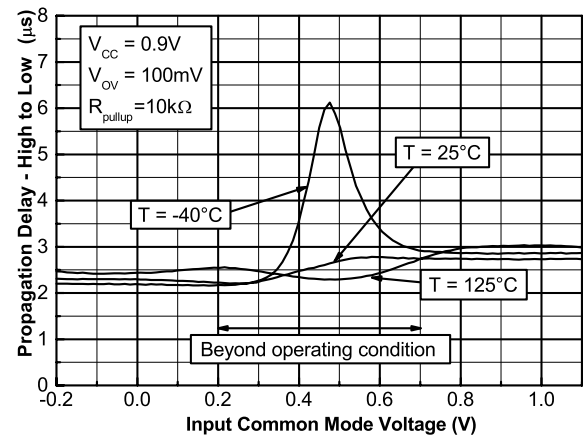

Figure 29. Propagation delay T_{PLH} vs. input common mode voltage, $V_{CC}=1.2\text{ V}$

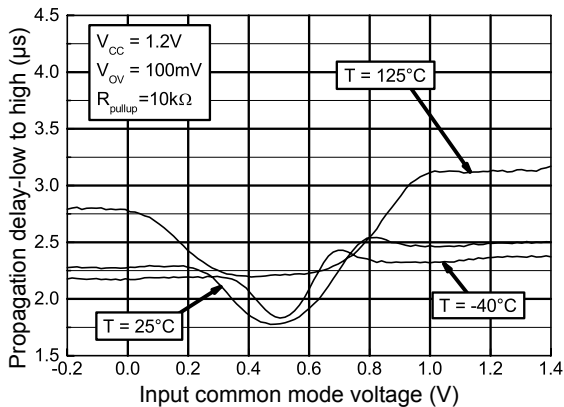

Figure 30. Propagation delay T_{PHL} vs. input common mode voltage, $V_{CC}=1.2\text{ V}$

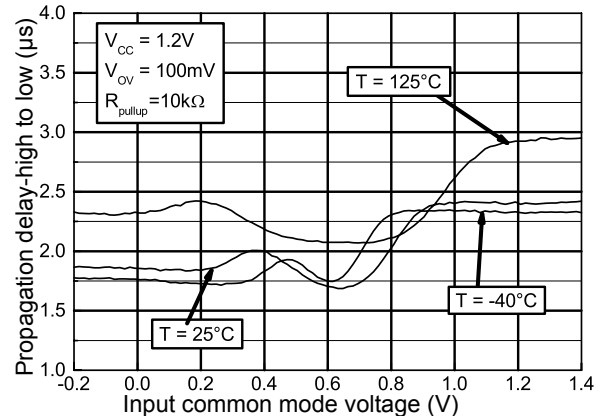

Figure 31. Propagation delay T_{PLH} vs. input common mode voltage, $V_{CC}=5V$

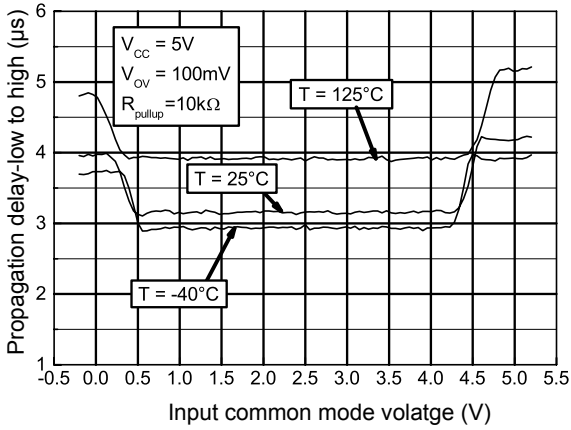

Figure 32. Propagation delay T_{PHL} vs. input common mode voltage, $V_{CC}=5V$

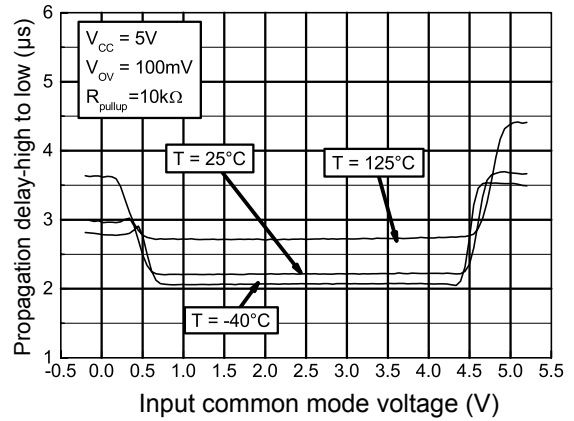

Figure 33. Propagation delay T_{PLH} vs. input signal overdrive, $V_{CC}=1.2V$

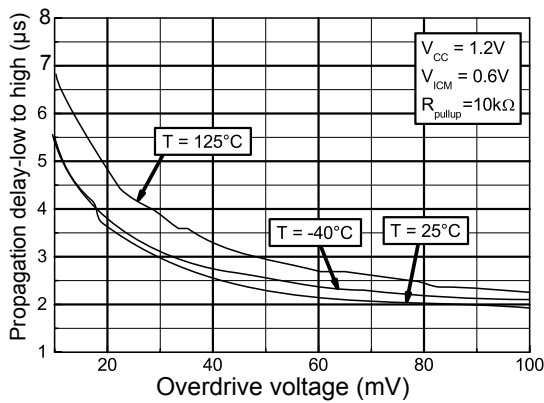

Figure 34. Propagation delay T_{PHL} vs. input signal overdrive, $V_{CC}=1.2V$

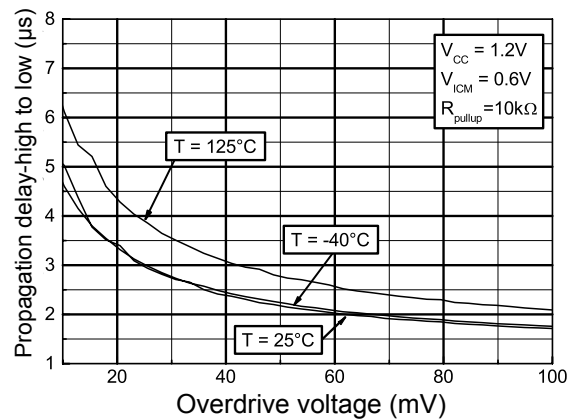

Figure 35. Current consumption Vs. input common mode voltage, $V_{CC}=0.9V$, output low

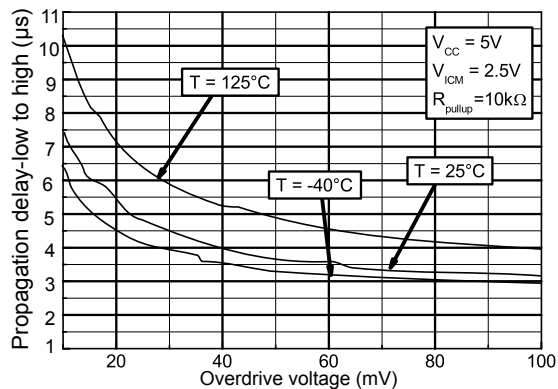

Figure 36. Current consumption Vs. input common mode voltage, $V_{CC}=0.9V$, output high

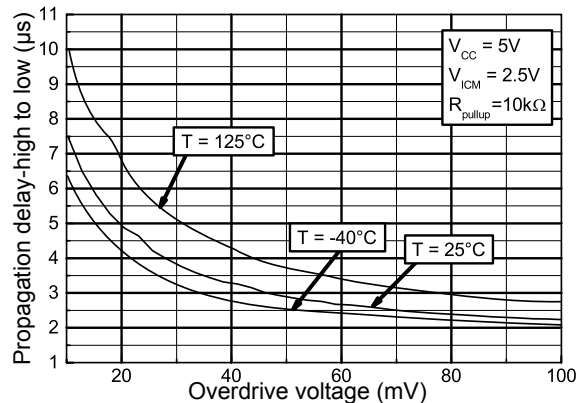

Figure 37. Propagation delay T_{PLH} vs. input signal overdrive, $V_{CC}=5\text{ V}$

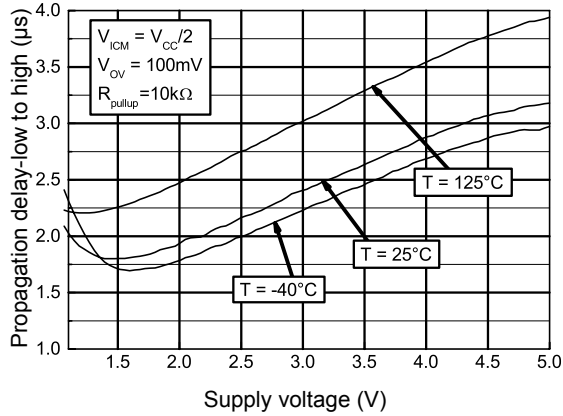

Figure 38. Propagation delay T_{PHL} vs. input signal overdrive, $V_{CC}=5\text{ V}$

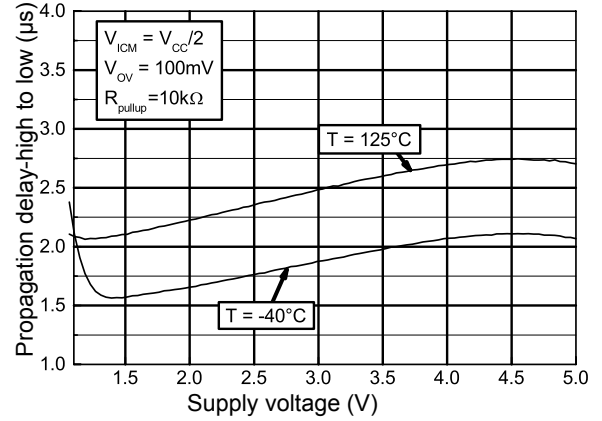

Figure 39. Propagation delay T_{PLH} vs. supply voltage

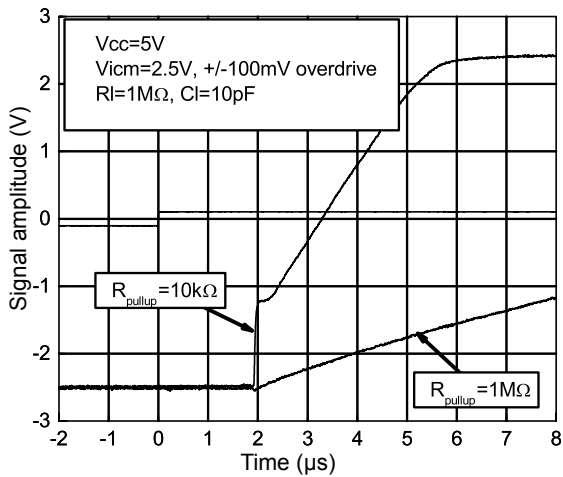
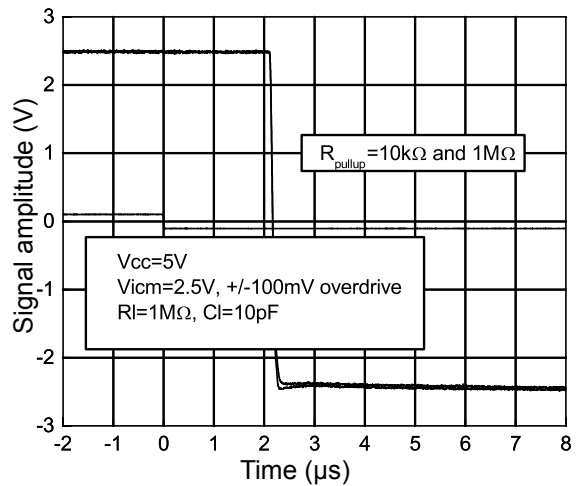

Figure 40. Propagation delay T_{PHL} vs. supply voltage



5 Package information

In order to meet environmental requirements, ST offers these devices in different grades of **ECOPACK** packages, depending on their level of environmental compliance. ECOPACK specifications, grade definitions and product status are available at: www.st.com. ECOPACK is an ST trademark.

5.1 SC70-5 (or SOT323-5) package information

Figure 41. SC70-5 (or SOT323-5) package outline

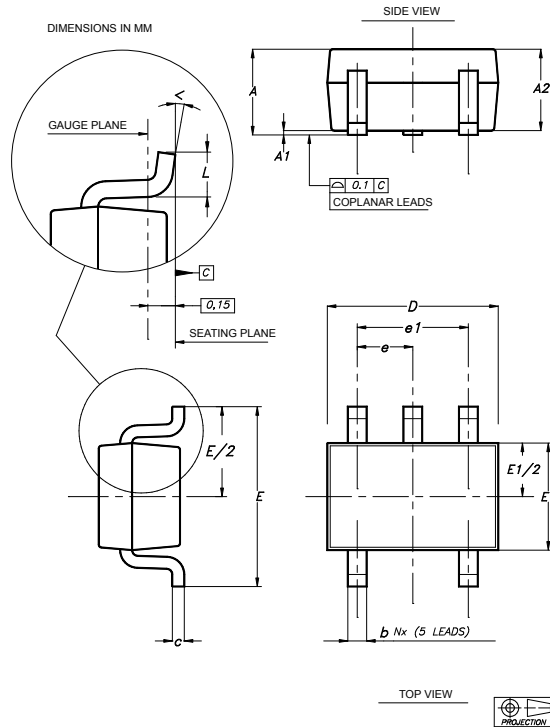
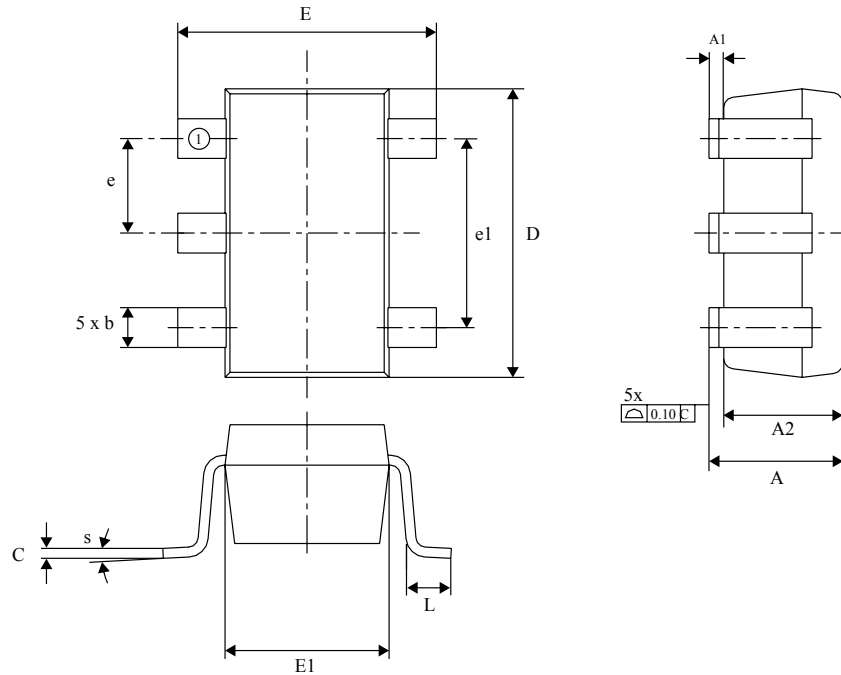

Table 7. SC70-5 (or SOT323-5) package mechanical data

Ref.	Dimensions					
	Millimeters			Inches		
	Min.	Typ.	Max.	Min.	Typ.	Max.
A	0.80		1.10	0.032		0.043
A1			0.10			0.004
A2	0.80	0.90	1.00	0.032	0.035	0.039
b	0.15		0.30	0.006		0.012
c	0.10		0.22	0.004		0.009
D	1.80	2.00	2.20	0.071	0.079	0.087
E	1.80	2.10	2.40	0.071	0.083	0.094
E1	1.15	1.25	1.35	0.045	0.049	0.053
e		0.65			0.025	
e1		1.30			0.051	
L	0.26	0.36	0.46	0.010	0.014	0.018
<	0°		8°	0°		8°

5.2 SOT23-5 package information

Figure 42. SOT23-5 package outline



SOT23-5

Table 8. SOT23-5 mechanical data

Symbol	Millimeters			Inches ⁽¹⁾		
	Min.	Typ.	Max.	Min.	Typ.	Max.
A			1.45			0.057
A1	0.00		0.15	0.000		0.006
A2	0.90	1.15	1.30	0.035	0.045	0.051
b	0.30		0.50	0.012		0.020
c	0.08		0.22	0.003		0.009
D		2.90			0.114	
E		2.80			0.110	
E1		1.60			0.063	
e		0.95			0.037	
e1		1.90			0.075	
L	0.30	0.45	0.60	0.012	0.018	0.024
θ	0	4	8	0	4	8

1. Values in inches are converted from mm and rounded to 4 decimal digits.

Figure 43. SOT23-5 recommended footprint

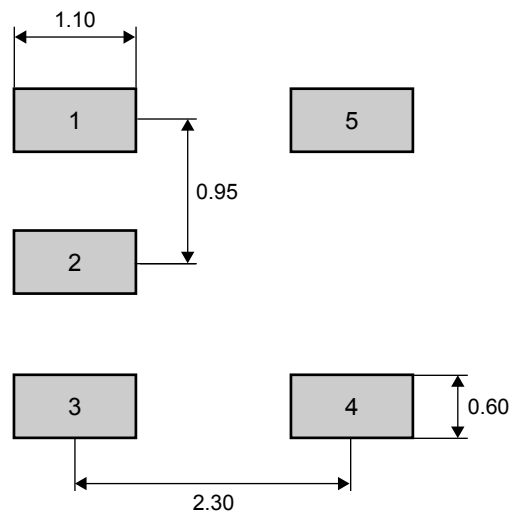

5.3 DFN8 2x2 package information

Figure 44. DFN8 2x2 package outline

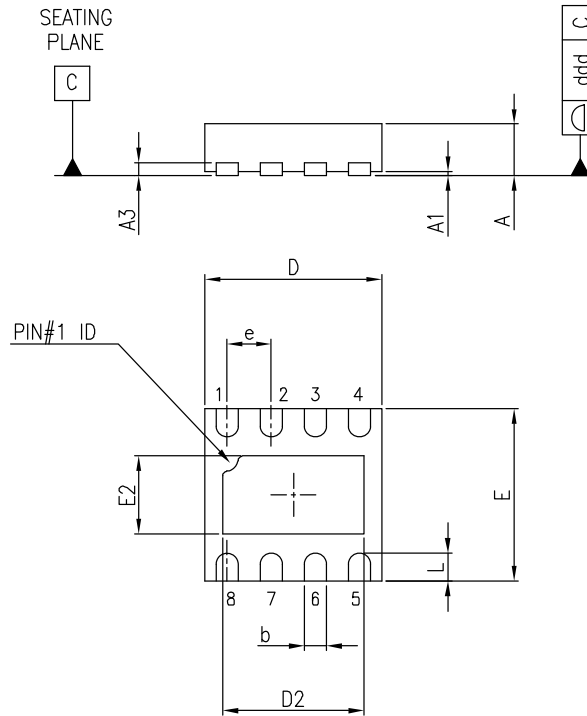
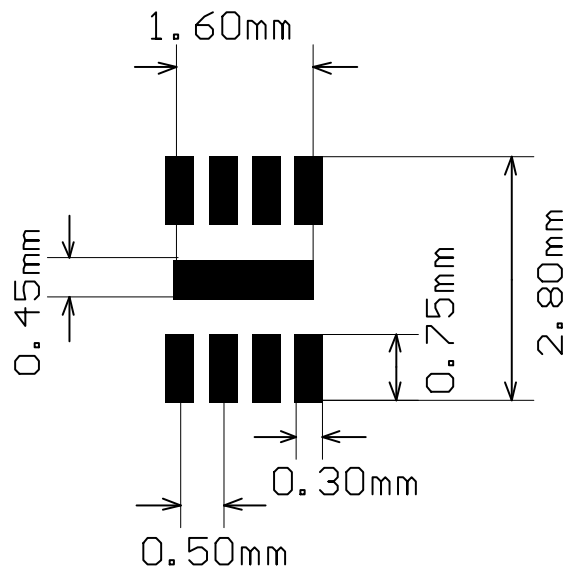

Table 9. DFN8 2x2 package mechanical data

Ref.	Dimensions					
	Millimeters			Inches		
	Min.	Typ.	Max.	Min.	Typ.	Max.
A	0.51	0.55	0.60	0.020	0.022	0.024
A1			0.05			0.002
A3		0.15			0.006	
b	0.18	0.25	0.30	0.007	0.010	0.012
D	1.85	2.00	2.15	0.073	0.079	0.085
D2	1.45	1.60	1.70	0.057	0.063	0.067
E	1.85	2.00	2.15	0.073	0.079	0.085
E2	0.75	0.90	1.00	0.030	0.035	0.039
e		0.50			0.020	
L	0.225	0.325	0.425	0.009	0.013	0.017
ddd			0.08			0.003

Figure 45. DFN8 2x2 recommended footprint



Note: The exposed pad of the DFN8 2x2 can be connected to VCC- or left floating.

5.4 MiniSO8 package information

Figure 46. MiniSO8 package outline

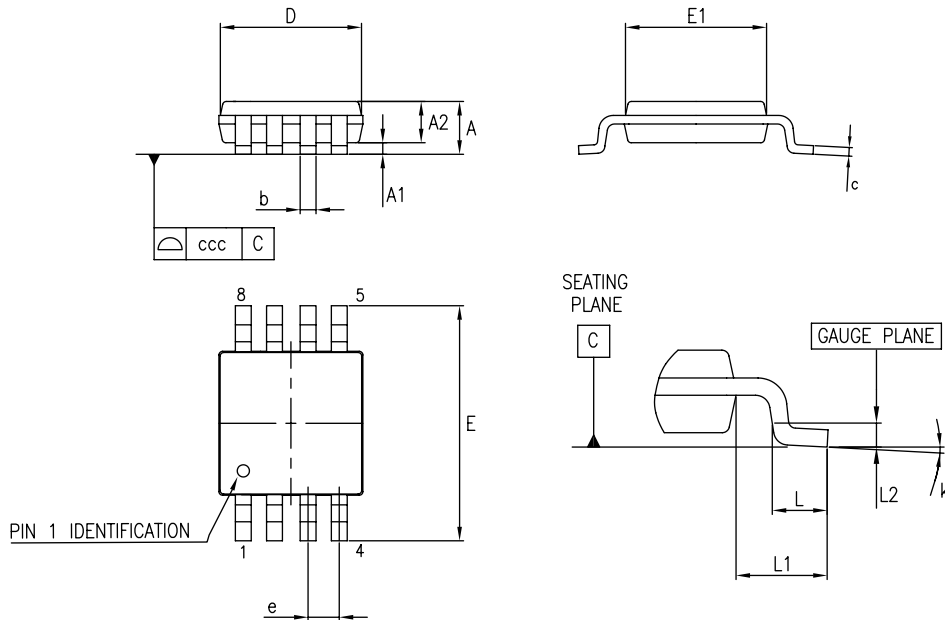

Table 10. MiniSO8 mechanical data

Dim.	Millimeters			Inches		
	Min.	Typ.	Max.	Min.	Typ.	Max.
A			1.1			0.043
A1	0		0.15	0		0.006
A2	0.75	0.85	0.95	0.03	0.033	0.037
b	0.22		0.4	0.009		0.016
c	0.08		0.23	0.003		0.009
D	2.8	3	3.2	0.11	0.118	0.126
E	4.65	4.9	5.15	0.183	0.193	0.203
E1	2.8	3	3.1	0.11	0.118	0.122
e		0.65			0.026	
L	0.4	0.6	0.8	0.016	0.024	0.031
L1		0.95			0.037	
L2		0.25			0.01	
k	0°		8°	0°		8°
ccc			0.1			0.004

6 Ordering information

Table 11. Order code

Order code	Temp. range	Package	Packing	Marking
TS880ICT	-40 to +125 °C	SC70-5	Tape and reel	K5P
TS880ILT		SOT23-5		K534
TS883IST		MiniSO8		K5Q
TS883IQ2T		DFN8 2x2 mm		

Revision history

Table 12. Document revision history

Date	Version	Changes
16-Apr-2019	1	Initial release.

Contents

1	Pin description	2
2	Absolute maximum ratings and operating conditions	3
3	Electrical characteristics	4
4	Typical characteristics and curves	12
5	Package information	19
5.1	Package information	20
5.2	SOT23-5 package information	21
5.3	DFN8 2x2 package information	23
5.4	MiniSO8 package information	25
6	Ordering information	26
	Revision history	27

List of tables

Table 1.	Absolute maximum ratings	3
Table 2.	Operating conditions	3
Table 3.	Electrical characteristics $V_{CC} = +0.9\text{ V}$, $T_{amb} = 25\text{ °C}$, $V_{ICM} = 0\text{ V}$ (unless otherwise specified).	4
Table 4.	Electrical characteristics $V_{CC} = +1.2\text{ V}$, $T_{amb} = 25\text{ °C}$, $V_{ICM} = V_{CC}/2$ (unless otherwise specified).	6
Table 5.	Electrical characteristics $V_{CC} = +2.7\text{ V}$, $T_{amb} = 25\text{ °C}$, $V_{ICM} = V_{CC}/2$ (unless otherwise specified).	8
Table 6.	Electrical characteristics $V_{CC} = +5\text{ V}$, $T_{amb} = 25\text{ °C}$, $V_{ICM} = V_{CC}/2$ (unless otherwise specified).	10
Table 7.	SC70-5 (or SOT323-5) package mechanical data	20
Table 8.	SOT23-5 mechanical data.	21
Table 9.	DFN8 2x2 package mechanical data	23
Table 10.	MiniSO8 mechanical data	25
Table 11.	Order code	26
Table 12.	Document revision history	27

List of figures

Figure 1.	Pin connection TS880 (top view)	2
Figure 2.	Pin connection TS883 (top view)	2
Figure 3.	Current consumption vs. supply voltage, $V_{icm}=V_{cc}$, output low	12
Figure 4.	Current consumption vs. supply voltage, $V_{icm}=V_{cc}$, output high	12
Figure 5.	Current consumption vs. supply voltage, $V_{icm}=0\text{ V}$, output low	12
Figure 6.	Current consumption vs. supply voltage, $V_{icm}=0\text{ V}$, output high	12
Figure 7.	Current consumption vs. input common mode voltage, $V_{cc}=0.9\text{ V}$, output low	13
Figure 8.	Current consumption vs. input common mode voltage, $V_{cc}=0.9\text{ V}$, output high	13
Figure 9.	Current consumption vs. input common mode voltage, $V_{cc}=5\text{ V}$, output low	13
Figure 10.	Current consumption vs. input common mode voltage, $V_{cc}=5\text{ V}$, output high	13
Figure 11.	Current consumption vs. temperature	13
Figure 12.	Current consumption vs. toggle frequency	13
Figure 13.	Input offset voltage vs. input common mode voltage, $V_{cc}=0.9\text{ V}$	14
Figure 14.	Input hysteresis voltage vs. input common mode voltage, $V_{cc}=0.9\text{ V}$	14
Figure 15.	Input offset voltage vs. input common mode voltage, $V_{cc}=1.2\text{ V}$	14
Figure 16.	Input hysteresis voltage vs. input common mode voltage, $V_{cc}=1.2\text{ V}$	14
Figure 17.	Input offset voltage vs. input common mode voltage, $V_{cc}=5\text{ V}$	14
Figure 18.	Input hysteresis voltage vs. input common mode voltage, $V_{cc}=5\text{ V}$	14
Figure 19.	Input offset voltage vs. temperature	15
Figure 20.	Input hysteresis voltage vs. temperature	15
Figure 21.	Output voltage drop vs. sink current, $V_{cc}=1.2\text{ V}$	15
Figure 22.	Output voltage drop vs. source current, $V_{cc}=1.2\text{ V}$	15
Figure 23.	Output voltage drop vs. sink current, $V_{cc}=2.7\text{ V}$	15
Figure 24.	Output voltage drop vs. source current, $V_{cc}=2.7\text{ V}$	15
Figure 25.	Output voltage drop vs. sink current, $V_{cc}=5\text{ V}$	16
Figure 26.	Output voltage drop vs. source current, $V_{cc}=5\text{ V}$	16
Figure 27.	Propagation delay T_{PLH} vs. input common mode voltage, $V_{cc}=0.9\text{ V}$	16
Figure 28.	Propagation delay T_{PHL} vs. input common mode voltage, $V_{cc}=0.9\text{ V}$	16
Figure 29.	Propagation delay T_{PLH} vs. input common mode voltage, $V_{cc}=1.2\text{ V}$	16
Figure 30.	Propagation delay T_{PHL} vs. input common mode voltage, $V_{cc}=1.2\text{ V}$	16
Figure 31.	Propagation delay T_{PLH} vs. input common mode voltage, $V_{cc}=5\text{ V}$	17
Figure 32.	Propagation delay T_{PHL} vs. input common mode voltage, $V_{cc}=5\text{ V}$	17
Figure 33.	Propagation delay T_{PLH} vs. input signal overdrive, $V_{cc}=1.2\text{ V}$	17
Figure 34.	Propagation delay T_{PHL} vs. input signal overdrive, $V_{cc}=1.2\text{ V}$	17
Figure 35.	Current consumption Vs. input common mode voltage, $V_{cc}=0.9\text{ V}$, output low	17
Figure 36.	Current consumption Vs. input common mode voltage, $V_{cc}=0.9\text{ V}$, output high	17
Figure 37.	Propagation delay T_{PLH} vs. input signal overdrive, $V_{cc}=5\text{ V}$	18
Figure 38.	Propagation delay T_{PHL} vs. input signal overdrive, $V_{cc}=5\text{ V}$	18
Figure 39.	Propagation delay T_{PLH} vs. supply voltage	18
Figure 40.	Propagation delay T_{PHL} vs. supply voltage	18
Figure 41.	SC70-5 (or SOT323-5) package outline	20
Figure 42.	SOT23-5 package outline	21
Figure 43.	SOT23-5 recommended footprint	22
Figure 44.	DFN8 2x2 package outline	23
Figure 45.	DFN8 2x2 recommended footprint	24
Figure 46.	MiniSO8 package outline	25

IMPORTANT NOTICE – PLEASE READ CAREFULLY

STMicroelectronics NV and its subsidiaries (“ST”) reserve the right to make changes, corrections, enhancements, modifications, and improvements to ST products and/or to this document at any time without notice. Purchasers should obtain the latest relevant information on ST products before placing orders. ST products are sold pursuant to ST’s terms and conditions of sale in place at the time of order acknowledgement.

Purchasers are solely responsible for the choice, selection, and use of ST products and ST assumes no liability for application assistance or the design of Purchasers’ products.

No license, express or implied, to any intellectual property right is granted by ST herein.

Resale of ST products with provisions different from the information set forth herein shall void any warranty granted by ST for such product.

ST and the ST logo are trademarks of ST. For additional information about ST trademarks, please refer to www.st.com/trademarks. All other product or service names are the property of their respective owners.

Information in this document supersedes and replaces information previously supplied in any prior versions of this document.

© 2019 STMicroelectronics – All rights reserved

Mouser Electronics

Authorized Distributor

Click to View Pricing, Inventory, Delivery & Lifecycle Information:

[STMicroelectronics:](#)

[TS880ICT](#)