

GENERAL DESCRIPTION

The SGM452 is an industry standard digital temperature sensor which integrates sigma-delta analog-to-digital converter (ADC) and I²C interface. This device is accurate to ±1°C in the range of -20°C to +85°C and ±1.2°C in the range of -55°C to +125°C. The SGM452 offers 12-bit digital temperature readings.

The power supply voltage of the device is from 2.7V to 5.5V. I²C interface is used to communicate with SGM452 and it operates up to 400kHz. There are three address pins of the devices to support eight SGM452 at most on the same I²C bus. There is an appropriate over-temperature output with programmable limit and hysteresis on SGM452. The programmable fault tolerance of the output can define the number of consecutive error conditions that must occur before OS is activated. The wide temperature, wide power supply range and I²C interface make the SGM452 ideal for plenty of applications in which thermal management is critical for performance, such as wireless base stations, notebook computers, personal computers, etc.

The SGM452 is available in Green SOIC-8 and MSOP-8 packages and operates over an ambient temperature range of -55°C to +125°C.

FEATURES

- Without External Components
- Minimize Power Consumption through Shutdown Mode
- Support Eight SGM452 Devices in One Serial Bus
- Power-Up Defaults Can be Opreate Stand-Alone as Thermostat
- Power Supply Voltage Range: 2.7V to 5.5V
- Support 1.8V I²C Bus Voltage at 3.3V Power Supply
- Low Quiescent Current: 49µA (TYP)
- Shutdown Mode Current: 0.4µA (TYP)
- Temperature Accuracy:
 - 20°C to +85°C: ±1°C (MAX)
 - 55°C to +125°C: ±1.2°C (MAX)
- Operating Temperature Range: -55°C to +125°C
- Available in Green SOIC-8 and MSOP-8 Packages

APPLICATIONS

Thermal Management in Computing System
 Telecom Infrastructure Equipment
 Environmental Monitoring

TYPICAL APPLICATION

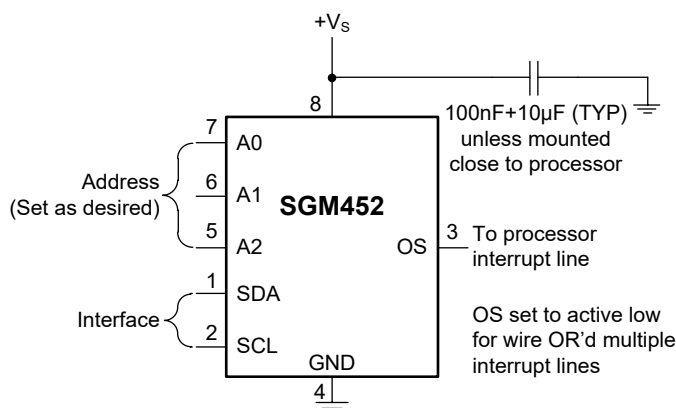

Figure 1. Typical Application Circuit

PACKAGE/ORDERING INFORMATION

MODEL	PACKAGE DESCRIPTION	SPECIFIED TEMPERATURE RANGE	ORDERING NUMBER	PACKAGE MARKING	PACKING OPTION
SGM452	SOIC-8	-55°C to +125°C	SGM452TS8G/TR	SGM 452TS8 XXXXX	Tape and Reel, 4000
	MSOP-8	-55°C to +125°C	SGM452TMS8G/TR	SGM452 TMS8 XXXXX	Tape and Reel, 4000

MARKING INFORMATION

NOTE: XXXXX = Date Code, Trace Code and Vendor Code.

XXXXX

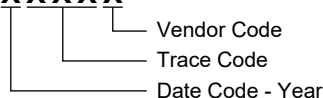

Green (RoHS & HSF): SG Micro Corp defines "Green" to mean Pb-Free (RoHS compatible) and free of halogen substances. If you have additional comments or questions, please contact your SGMICRO representative directly.

ABSOLUTE MAXIMUM RATINGS

Supply Voltage Pin (+V _S)	-0.3V to 6V
Voltage at A0, A1 and A2 Pins	-0.3V to (+V _S + 0.3V)
Voltage at OS, SCL and SDA Pins	-0.3V to 6V
Input Current at Any Pin ⁽¹⁾	5mA
Package Input Current	20mA
OS Output Sink Current	10mA
OS Output Voltage	6V
Junction Temperature	+150°C
Storage Temperature Range	-65°C to +150°C
Lead Temperature (Soldering, 10s)	+260°C
ESD Susceptibility	
HBM	4000V
CDM	1000V

NOTE:

1. If the input voltage of any pin (V_{IN}) is higher than the supply voltage (V_{IN} < GND or V_{IN} > +V_S), the maximum current of this pin should be 5mA. The number of pins with current safely exceeding the power supplies is limited to four since the maximum input rating current is 20mA.

RECOMMENDED OPERATING CONDITIONS

Supply Voltage Range (+V _S)	2.7V to 5.5V
Operating Temperature Range	-55°C to +125°C

OVERSTRESS CAUTION

Stresses beyond those listed in Absolute Maximum Ratings may cause permanent damage to the device. Exposure to absolute maximum rating conditions for extended periods may affect reliability. Functional operation of the device at any conditions beyond those indicated in the Recommended Operating Conditions section is not implied.

ESD SENSITIVITY CAUTION

This integrated circuit can be damaged by ESD if you don't pay attention to ESD protection. SGMICRO recommends that all integrated circuits be handled with appropriate precautions. Failure to observe proper handling and installation procedures can cause damage. ESD damage can range from subtle performance degradation to complete device failure. Precision integrated circuits may be more susceptible to damage because very small parametric changes could cause the device not to meet its published specifications.

DISCLAIMER

SG Micro Corp reserves the right to make any change in circuit design, or specifications without prior notice.

PIN CONFIGURATIONS

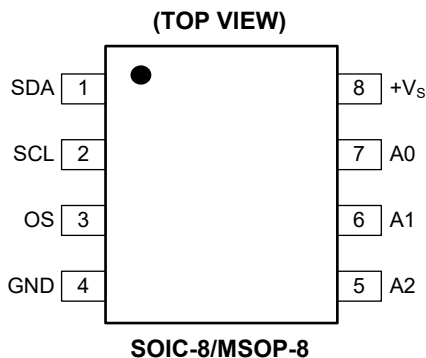

PIN DESCRIPTION

PIN	NAME	FUNCTION
1	SDA	Data Input/Output Pin. Open-drain output. From controller, tied to a pull-up resistor or current source.
2	SCL	Clock Input Pin. Open-drain output. From controller, tied to a pull-up resistor or current source.
3	OS	Over-Temperature Shutdown Output. Open-drain output. Pull-up resistor, controller interrupt line.
4	GND	Ground.
5	A2	Address Selecting Pin. Connect it to VCC to set high, connect it to GND to set low.
6	A1	
7	A0	
8	+Vs	2.7V to 5.5V Power Supply Pin. Connect a 0.1µF bypass capacitor and a 10µF bulk capacitor near +Vs.

ELECTRICAL CHARACTERISTICS

(+V_S = 3.3V, T_A = T_J = -55°C to +125°C, typical values are at T_A = T_J = +25°C, unless otherwise noted.)

PARAMETER	SYMBOL	CONDITIONS	MIN	TYP	MAX	UNITS
Temperature-to-Digital Converter Characteristics						
Temperature Accuracy	T _{ACC}	T _A = T _J = -20°C to +85°C	-1	±0.2	1	°C
		T _A = T _J = -55°C to +125°C	-1.2	±0.2	1.2	°C
Power Supply Sensitivity				0.02	0.08	°C/V
Temperature Resolution				12		Bits
Temperature Conversion Time ⁽¹⁾	t _{CON}		90	100	110	ms
Quiescent Current	I _{DD}	I ² C inactive, +V _S = 2.7V		46	65	μA
		I ² C inactive, +V _S = 3.3V		49	70	
		I ² C inactive, +V _S = 5.5V		64	85	
		Shutdown mode, +V _S = 5.5V		0.4	3	
OS Output Saturation Voltage		I _{OUT} = 3mA		0.06	0.3	V
OS Delay ⁽²⁾			1		6	Conversion
T _{OS} Default Temperature				80		°C
T _{HYST} Default Temperature				75		°C
Digital DC Characteristics						
SCL SDA High-Level Input Voltage	V _{IH,S}	+V _S = 5.5V	1.7			V
		+V _S = 3.6V	1.4			
SCL SDA Low-Level Input Voltage	V _{IL,S}	+V _S = 2.7V			0.6	V
A0 A1 A2 High-Level Input Voltage	V _{IH,A}	+V _S = 5.5V	0.6 × (+V _S)			V
A0 A1 A2 Low-Level Input Voltage	V _{IL,A}	+V _S = 2.7V			0.4 × (+V _S)	V
High-Level Input Current	I _{IH}	+V _S = 5.5V		0.01	1	μA
All Digital Inputs	C _{IN}			5		pF
SDA High-Level Output Current	I _{OH}	V _{OH} = 5V		0.01	1	μA
SDA Low-Level Output Voltage	V _{OL}	I _{OL} = 3mA		0.06	0.3	V
I²C Digital Switching Characteristics						
SCL Clock Period	t _{CLK}	T _A = T _J = +25°C	2.5			μs
Data in Set-Up Time to SCL High	t _{HIGH}	T _A = T _J = +25°C	100			ns
Data Out Stable after SCL Low	t _{LOW}	T _A = T _J = +25°C	0			ns
SDA Low Set-Up Time to SCL Low (Start Condition)	t _{SUSTA}	T _A = T _J = +25°C	100			ns
SDA High Hold Time after SCL High (Stop Condition)	t _{HDSTO}	T _A = T _J = +25°C	100			ns
SDA Time Low for Reset of Serial Interface ⁽³⁾	t _{TIMEOUT}	T _A = T _J = +25°C	20		30	ms

NOTES:

- The frequency of updating temperature data is indicated by providing a conversion time specification. The SGM452 can read temperature at any time for the last temperature conversion result.
- Before OS is configured, OS delay can be up to 6 "over limit" conversions by user programming to reduce false tripping under noisy environments.
- When the holding time for SDA line low exceeds t_{TIMEOUT}, the SGM452 will reset SDA to the IDLE state (SDA = high) of the serial bus communication.

I²C DIGITAL SWITCHING CHARACTERISTICS

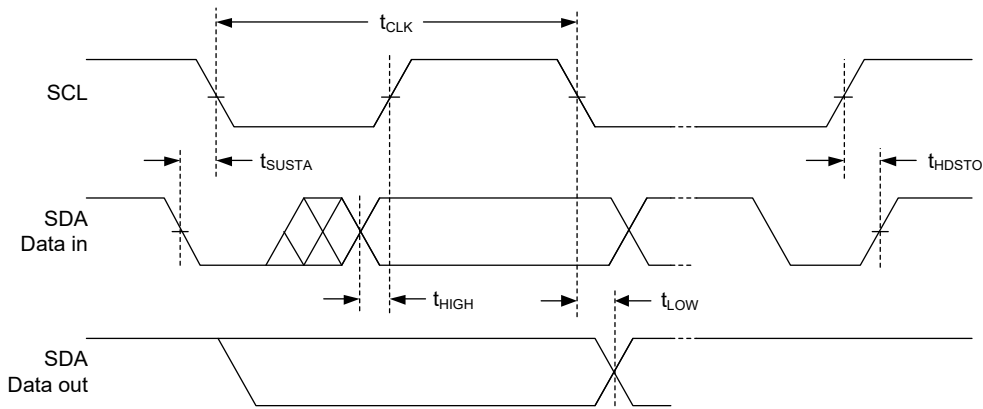
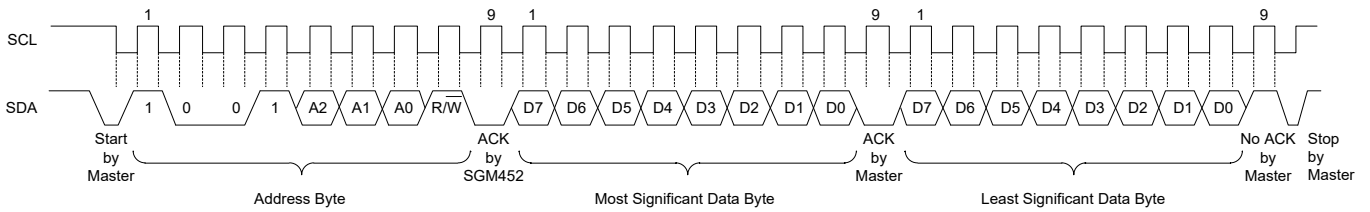
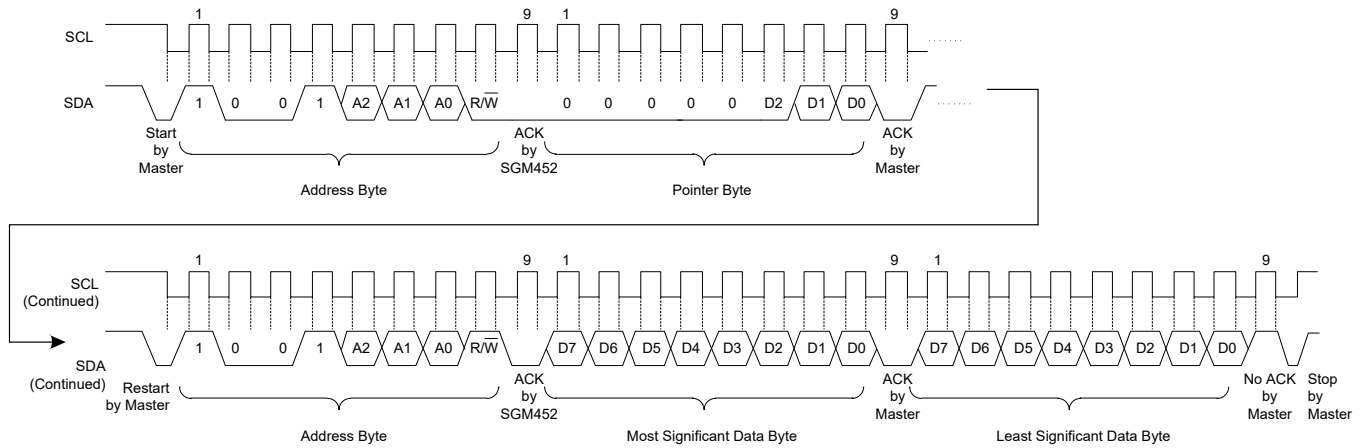

Figure 2. Timing Diagram



(a) 2-Byte Read from Preset Pointer Location Such as Temperature, T_{OS} and T_{HYST}



(b) Pointer Set Followed by Immediate Read for 2-Byte Register Such as Temperature, T_{OS} and T_{HYST}

Figure 3. I²C Timing Diagram

I²C DIGITAL SWITCHING CHARACTERISTICS (continued)

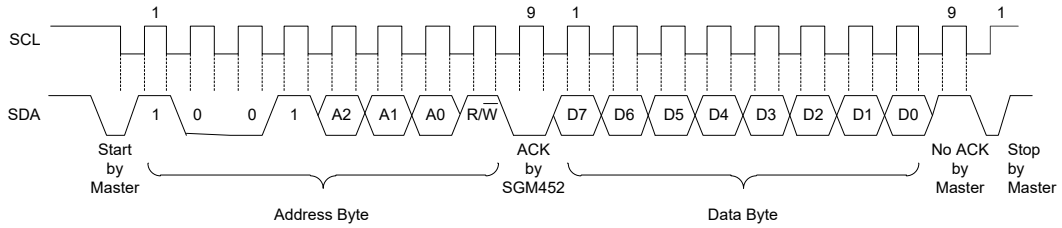

(a) 1-Byte Read from Configuration Register with Preset Pointer

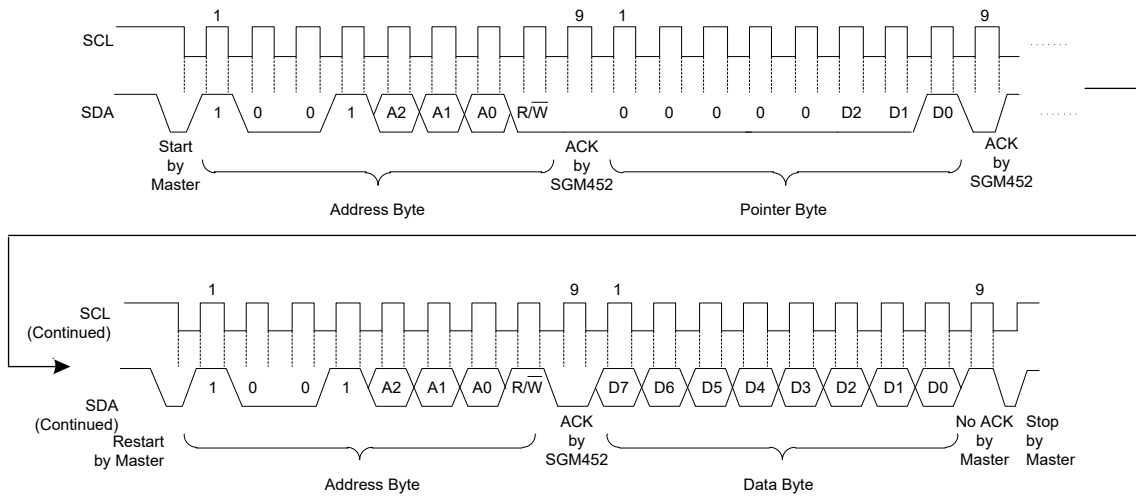

(b) Pointer Set Followed by Immediate Read from Configuration Register

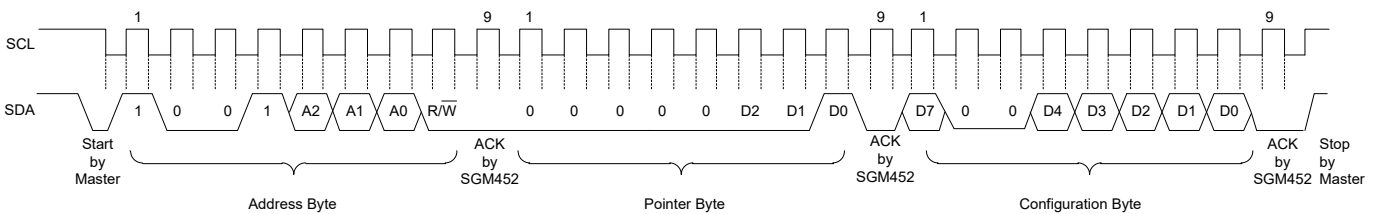

(c) Write to Configuration Register

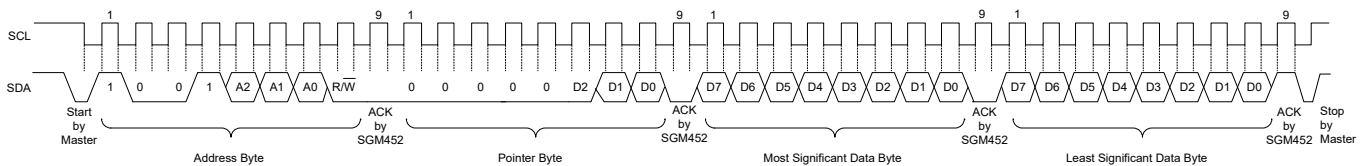

(d) Write to T_{OS} and T_{HYST}

Figure 4. I²C Timing Diagram (continued)

FUNCTIONAL BLOCK DIAGRAM

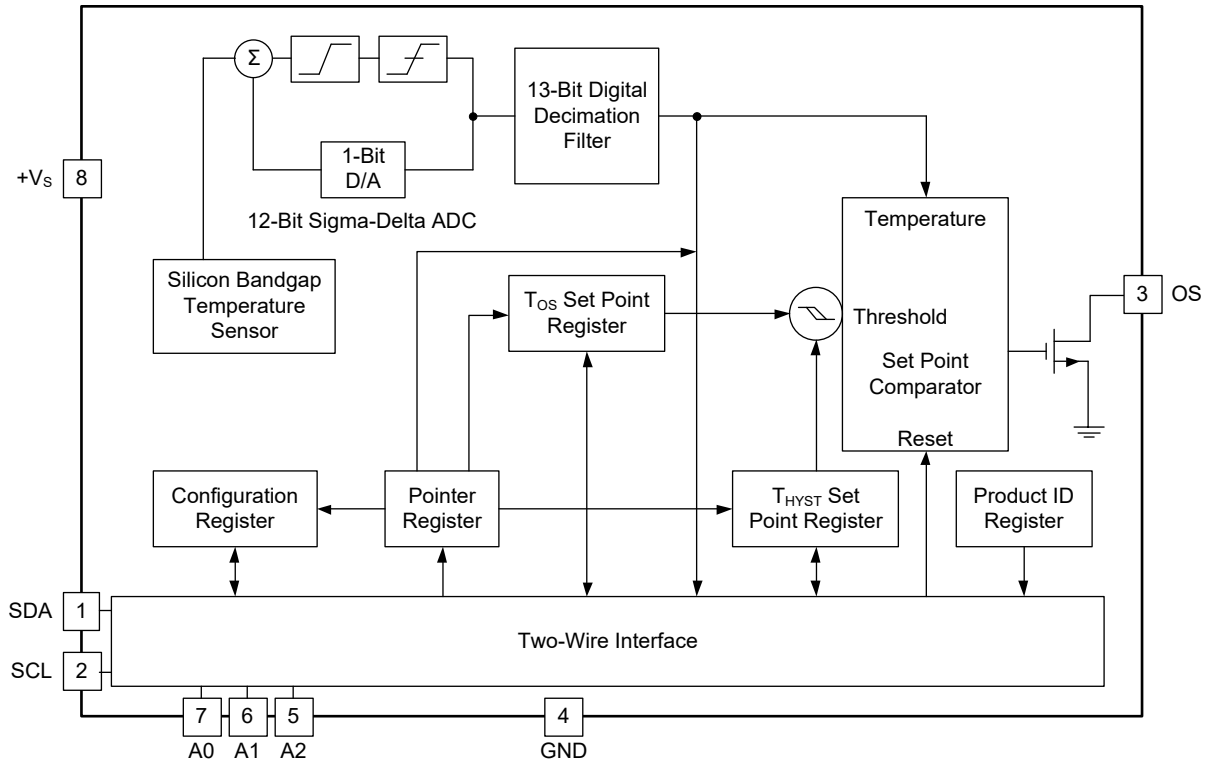

Figure 5. Block Diagram

DETAILED DESCRIPTION

General Operation

The SGM452 digital temperature sensor integrates a bandgap temperature sensor and a 12-bit sigma-delta ADC. The temperature register of the device is accessible at any time through SCL and SDA line. Reading temperature data has no effect on the conversion in progress. The SGM452 also contains a digital comparator that can compare the converted temperature data selected by users, as well as T_{OS} and T_{HYST} values configured by users. The OS output pin can be triggered by the comparator. The mode and polarity of the OS pin are programmable. The low-pass filters that can decrease the noise in complex environments are also incorporated on the I²C bus lines.

The SGM452 also has a bus fault timeout function. It will change to the IDLE condition (SDA is in high-impedance mode) and ready to respond a new start command when the holding time for SDA line low exceeds $t_{TIMEOUT}$. The timeout feature will be ineffective under shutdown mode.

Device Functional Modes

In comparator mode, the OS output acts as a thermostat. The output is activated once the temperature is higher than T_{OS} limit, and is deactivated once the temperature is lower than T_{HYST} limit. The OS output in this mode can be used to enable cooling fan, trigger emergency system shutdown and decelerate the speed. In shutdown mode, OS is not reset to initial condition in a comparator mode.

In interrupt mode, exceeding T_{OS} also activates OS. However, OS will not be reset indefinitely unless the host accesses any register. When exceeding T_{OS} activated OS and OS reset, only dropping out T_{HYST} activated OS again. OS will not be reset indefinitely until any register is read by I²C interface. Configuring SGM452 to shutdown mode also resets OS output.

The SGM452 always powered up on some conditions. In comparator mode, T_{OS} is +80°C, T_{HYST} is +75°C, OS is active low and pointer is "00" When the power supply drops to about 2.6V, the SGM452 is regarded as powered down. The internal registers will reset to default values if the power supply exceeds the rated power-up threshold of 2.6V.

During power-on process, if the SGM452 is disconnected from the I²C bus, it will act as an independent thermostat and is in the power-up default state. It is recommended to

connect the address pins (A2, A1, A0), SCL and SDA pins together. Pull up a 10kΩ resistor to +V_S to reduce noise interference. Each pin described above can be pulled up to high level in isolation through a 10kΩ resistor.

I²C Bus Interface

The SGM452 works as a slave on the I²C bus, so the SCL line is an input (no clock signal produced from SGM452), and the SDA is a bi-directional serial data line. Based on I2C protocol, the SGM452 should have a 7-bit slave address. Four most significant bits of the slave address are hard-wired inside the SGM452 and they are "1001". The last three bits of the address are determined by A0,A1 and A2 pins. Connect these pins to GND to set "0", Connect these pins to +V_S to set "1".

The complete slave address is shown in Table 1.

Table 1. Complete Slave Address

1	0	0	1	A2	A1	A0
MSB			LSB			

Digital Temperature Output

The digital output from each temperature measurement is stored in the read-only temperature register. The temperature register of the SGM452 is configured as a 12-bit, read-only register. The set point register of T_{OS} or T_{HYST} is also configured as a 12-bit register, from which temperature data can be read and written to. Temperature data format is indicated in Table 2. One LSB is equal to 0.0625°C. Negative numbers are expressed by binary complement format.

Table 2. 12-Bit Temperature Data Format

Temperature	Digital Temperature Output	
	Binary	Hex
+125°C	0111 1101 0000	7D0h
+25°C	0001 1001 0000	190h
+0.5°C	0000 0000 1000	008h
+0.0625°C	0000 0000 0001	001h
0°C	0000 0000 0000	000h
-0.0625°C	1111 1111 1111	FFFh
-0.5°C	1111 1111 1000	FF8h
-25°C	1110 0111 0000	E70h
-55°C	1100 1001 0000	C90h

DETAILED DESCRIPTION (continued)

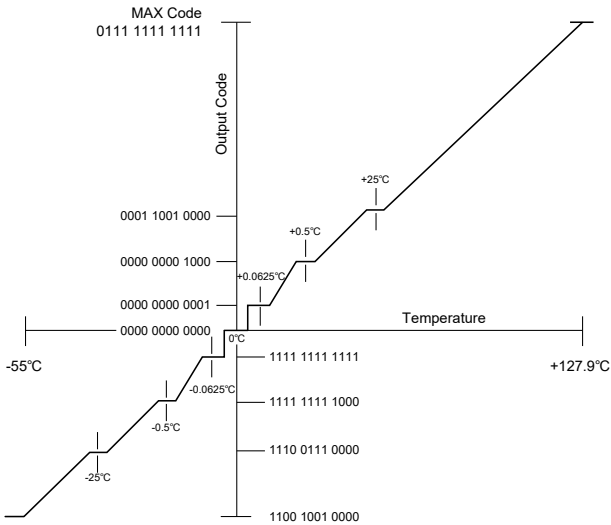

Figure 6. Temperature-to-Digital Transfer Function (Not Linear Scale for Clarity)

Shutdown Mode

Low power shutdown mode is activated when the mode bit D[0] = 1 in the configuration register. This mode saves power obviously by shutting down the most device circuitry of SGM452. In interrupt mode, if OS is set in advance, OS will reset and be undefined in comparator mode during shutdown. The SCL and SDA communication lines keep active. Changes on the I²C bus lines will slightly increase the quiescent power in shutdown mode. T_{OS}, T_{HYST}, and configuration registers can be read from and written to. The timeout feature will be disabled in shutdown mode of the SGM452.

Fault Queue

A fault queue (maximum setting can reach 6) is used to avoid error tripping of OS when the SGM452 is in a noisy environment. The fault queue requires consecutive fault measurements in order to trigger the OS pin.

Comparator and Interrupt Modes

As indicated in Figure 7, the events that trigger OS are the same for both comparator and the interrupt mode. The main difference is that the OS will keep

active indefinitely in interrupt mode when it has been set. Complete a read command to any register in the SGM452 to reset OS in interrupt mode.

OS Output

The OS output is open-drain and does not require internal pull-up resistor. The open-drain structure can only output low level, so pull-up current must be needed from some external source to achieve a high level, usually a pull-up resistor. Selection of resistor value is mainly determined by the current filling capacity of the pins and communication rate, but in general, the higher the pull-up resistance, the better the performance. This will greatly reduce errors caused by heating inside the SGM452.

OS Polarity

The OS output polarity can be set to be active high or active low (default mode) by the configuration register. In active low mode, the OS output becomes low when it is activated exactly as indicated in Figure 7. In active high mode, the OS output polarity will be inverted.

For interrupt mode, resets of OS appear only when SGM452 is read or set in shutdown. Otherwise, OS will keep the previous state in any cases.

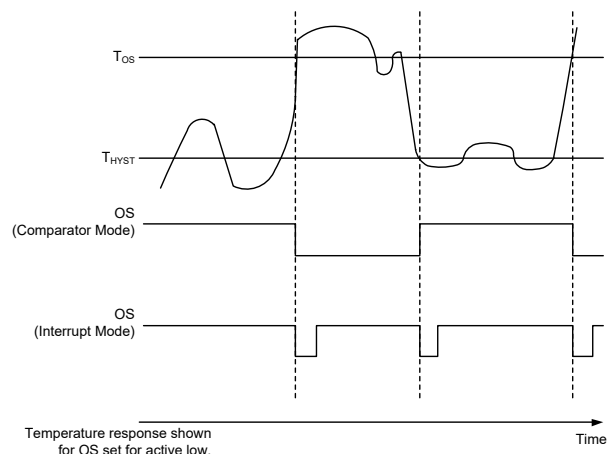

Figure 7. OS Output Temperature Response

DETAILED DESCRIPTION (continued)

Internal Register Structure

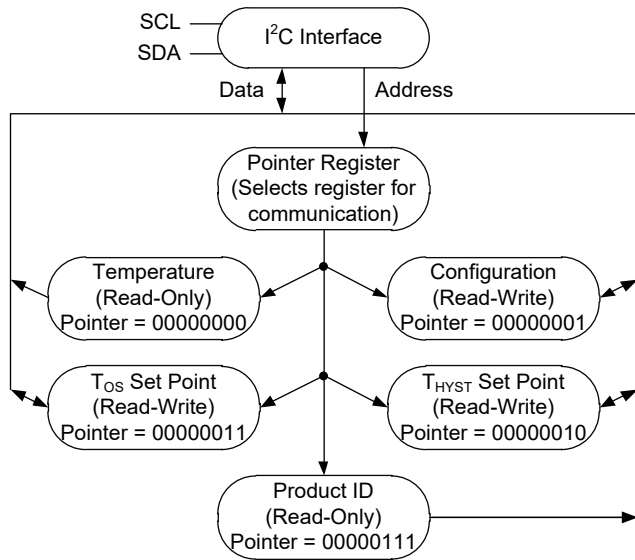

Figure 8. Register Structure

Figure 8 indicates the internal register structure of the SGM452. The device contains four data registers and an extra product ID register that can be selected by the pointer register. Table 3 indicates the bits of the pointer register. The power-up default value of D[2:0] is 000. The pointer register stores the last value it was set to. In interrupt mode, read operation from the SGM452 or setting the SGM452 in shutdown mode sets the OS output to default. Each register can be accessed by read and write operation, except two read-only registers of temperature and the product ID of SGM452.

Address byte and pointer byte are contained when writing to SGM452. When accessing to the configuration register, one data byte is needed. And two data bytes are needed for writing to the T_{OS} and T_{HYST} set point registers.

Access to SGM452 registers for data only occur in two ways: If the pointer latches right position(usually the pointer register value is supposed to be '0x00' because temperature is the most frequent data read from the SGM452), then the read command can only contain one address byte, and next retrieve relative number of data bytes. If the pointer requires pointing to other registers, this can be completed by sending an address byte, pointer byte, repeat start, and another address byte to the slave.

The first data byte, which only allows to obtain essential data for a certain temperature condition, is the most significant byte with most significant bit first. For example, when the first four bits of data byte reflect an over-temperature condition, the host processor can act at once to decrease the excessive temperatures. When the read comes to an end, the master will send either acknowledge or no acknowledge to the SGM452 (no acknowledge usually indicates that the master has read its last byte from the slave)

REGISTER MAP

Pointer Register

Table 3. Pointer Register

BITS	BIT NAME	RESET	DESCRIPTION
D[7:3]	—	00000	Must be kept "0" (zero).
D[2:0]	Register Select Register	000	Select which registers will be read from or written to. 000 = Temperature Register (R) (Power-Up Default) 001 = Configuration Register (R/W) 010 = T _{HYST} Register (R/W) 011 = T _{OS} Register (R/W) 111 = Product ID Register

Temperature Register (Address = 00000000)

Table 4. Temperature Register

BITS	BIT NAME	TYPE	DESCRIPTION
D[15:4]	Temperature Data	R	Temperature data. Two's Complement Format. One LSB = 0.0625°C.
D[3:0]	—	R	Undefined.

Configuration Register (Address = 00000001)

Table 5. Configuration Register Details (power-up default is with all bits "0".)

BITS	BIT NAME	TYPE	DESCRIPTION
D[7]	BUS_FLEX	R/W	0: Disable leakage blocking circuit for the scenario that I ² C bus voltage is lower than +V _S of the part. The I ² C interface is still functional but +V _S sees leakage when V _{BUS} < +V _S - 0.3V. At below two combinations V _{BUS} = 1.8V, +V _S = 3.3V, or V _{BUS} = 3.3V, +V _S = 5.0V, set BUS_FLEX to 1 will remove leakage current with a little increase of power down current.
D[6]	—	R/W	Product testing bits. Must be kept "0" (zero).
D[5]	—	R/W	Product testing bits. Must be kept "0" (zero).
D[4:3]	FAULT_QUEUE[1:0]	R/W	Number of faults are needed to monitor before setting OS output to prevent error tripping from noise. Faults are determined at the end of a conversion. Specified temperature conversion time can be found in the electrical characteristics table. 00 = 1 (Power-up default) 01 = 2 10 = 4 11 = 6
D[2]	OS_POLARITY	R/W	OS is always an open-drain output. 0 = active low; 1 = active high.
D[1]	CMP_INT	R/W	Comparator/Interrupt mode. 0 = comparator mode; 1 = interrupt mode.
D[0]	SHUTDOWN	R/W	1 = low power shutdown mode.

REGISTER MAP (Continued)**T_{HYST} and T_{OS} Set Point Registers (Address = 00000001 for T_{HYST} and 00000011 for T_{OS})****Table 6. T_{HYST} and T_{OS} Registers Details**

BITS	BIT NAME	TYPE	DESCRIPTION
D[15:4]	T _{HYST} or T _{OS} Trip Temperature Data	R/W	Power-up default: T _{OS} = +80°C (Binary: 010100000000) T _{HYST} = +75°C (Binary: 010010110000).
D[3:0]	—	R/W	Undefined.

Product ID Register (Address = 00000111)**Table 7. Product ID Register Details**

BITS	BIT NAME	RESET	TYPE	DESCRIPTION
D[7:4]	Product Identification Nibble	1010	R	It is used to identify the product as the SGM452
D[3:0]	Die Revision Nibble	001	R	It is used to identify the die revision level as one

APPLICATION INFORMATION

Simple temperature control system, Interface Optional

The SGM452 features wide power supply range, wide temperature range and I²C interface. It is ideal for plenty of applications in which thermal stability is critical for performance, such as wireless base stations, data server, laptop, environmental temperature monitoring, etc. In Figure 9 and Figure 10, R₃ is optional but recommended pull-up in stand-alone mode.

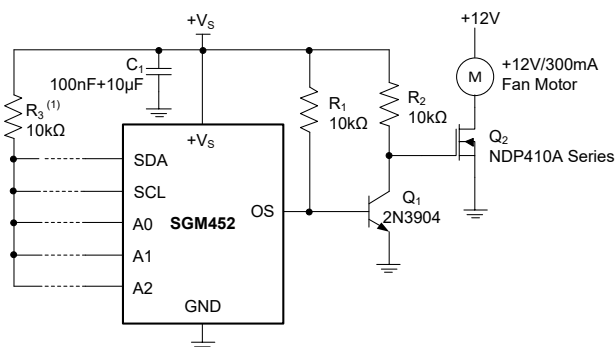

NOTE:

1. when two-wired interface is applied, OS polarity should be set for active high and tied to Q₁'s base directly.

Figure 9. Simple temperature control system, Interface Optional

Design Requirements

The voltage between +V_S and GND of the SGM452 has a wide range from 2.7V to 5.5V. For best results, a 100nF bypass capacitor with a 10µF bulk capacitance near +V_S are recommended as shown in Figure 9. The SGM452 device requires pull-up resistors on the SCL and SDA pins. The recommended value of the pull-up resistors is 10kΩ.

Detailed Design Procedure

To acquire the temperature data of the SGM452, the read command of which timing diagram shown in Figure 3 is indispensable. Note that byte 1 is the most significant byte, followed by byte 2, the least significant byte, only allowing reading necessary data to certain temperature condition. For example, if the most significant data byte of the temperature register reflects an over-temperature condition, the host controller could act at once to decrease the temperatures. When the read comes to an end, the master will send either acknowledge or no acknowledge to the SGM452 (no acknowledge usually indicates that the master has read its last byte from the slave). Temperature data is two's complement format and one LSB represents 0.0625°C.

System Examples

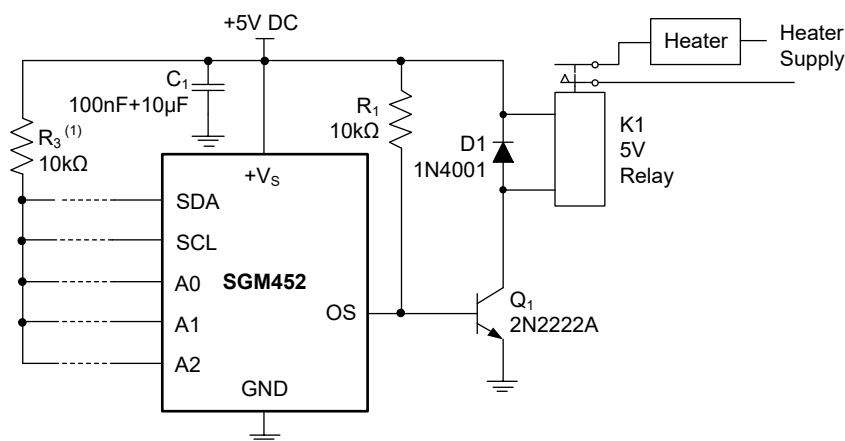

Figure 10. Simple Thermostat, Interface Optional

LAYOUT

Layout Guidelines

When using SGM452 for temperature measurement, it is essential to know that the device measures its own die temperature. For the SGM452, the heat path from the outside to the die is the best way for measurement. In the MSOP-8 package, the ground pin and the device die have been tied together, therefore, a good temperature measurement path can be achieved by the ground pin. If the temperatures of the other pins are different, this will have an impact on the measured temperature but less than the ground pin. In the SOIC-8 package, there are no pins directly connected to the die, so it has a similar effect on the temperature of the die. Due to the good thermal path to the SGM452 die provided by the pins, the SGM452 can accurately acquire the temperature of the PCB it is mounted on. The heat conduction from the plastic package to the SGM452 die will provide a lower efficiency. Vast temperature variations between printed circuit board

temperature and ambient temperature case a small effect on the measured temperature.

The SGM452 can reduce the bus noise through an integrated low-pass filter on I²C bus lines. This noise filter improves the SGM452 anti-noise ability, good layout and routing are still recommended to reduce noise coupling. For example, the I²C digital bus trace must be kept a distance from switching power supplies. If the digital lines work in a high-speed data communication mode, there is a necessary cross at right angles between them and the SDA and SCL lines. Overshoot power supply by 0.3V or undershoot GND by 0.3V will affect the normal communication with the SGM452. Although the maximum operate frequency of the serial bus is only 400kHz, the suitable termination within a system with long layout routing or multiple modules on the communication lines should be carefully considered.

REVISION HISTORY

NOTE: Page numbers for previous revisions may differ from page numbers in the current version.

JULY 2021 – REV.A to REV.A.1	Page
Updated Detailed Description section	5

Changes from Original (NOVEMBER 2020) to REV.A	Page
Changed from product preview to production data.....	All

PACKAGE OUTLINE DIMENSIONS

SOIC-8

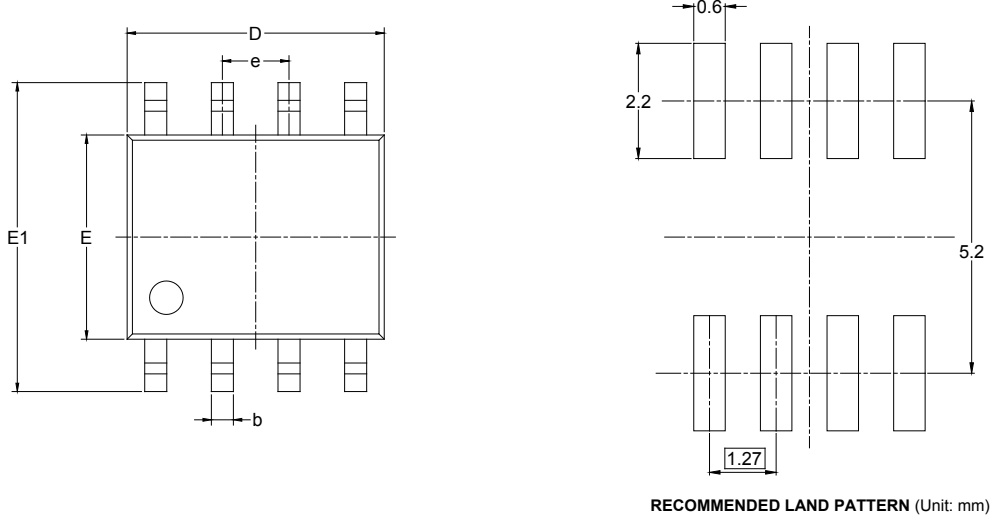

Symbol	Dimensions In Millimeters		Dimensions In Inches	
	MIN	MAX	MIN	MAX
A	1.350	1.750	0.053	0.069
A1	0.100	0.250	0.004	0.010
A2	1.350	1.550	0.053	0.061
b	0.330	0.510	0.013	0.020
c	0.170	0.250	0.006	0.010
D	4.700	5.100	0.185	0.200
E	3.800	4.000	0.150	0.157
E1	5.800	6.200	0.228	0.244
e	1.27 BSC		0.050 BSC	
L	0.400	1.270	0.016	0.050
θ	0°	8°	0°	8°

PACKAGE OUTLINE DIMENSIONS

MSOP-8

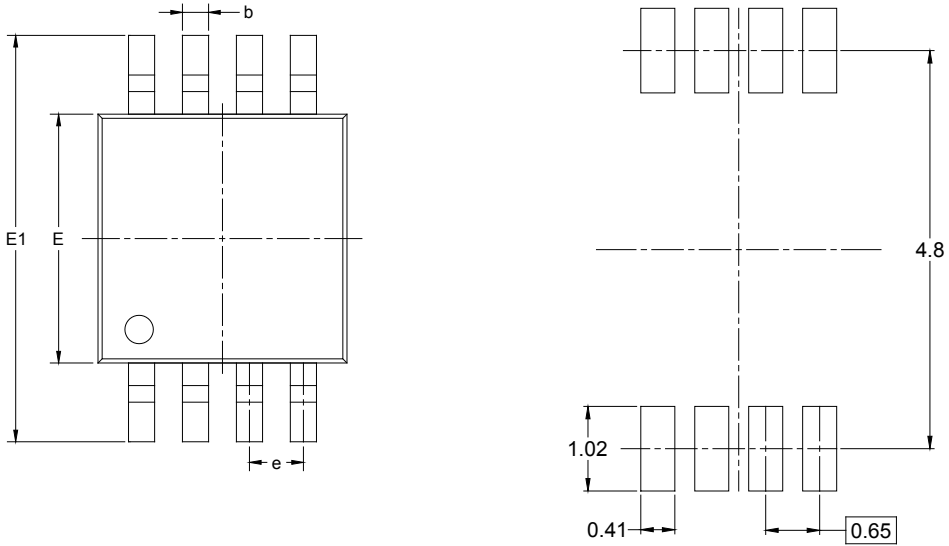

RECOMMENDED LAND PATTERN (Unit: mm)

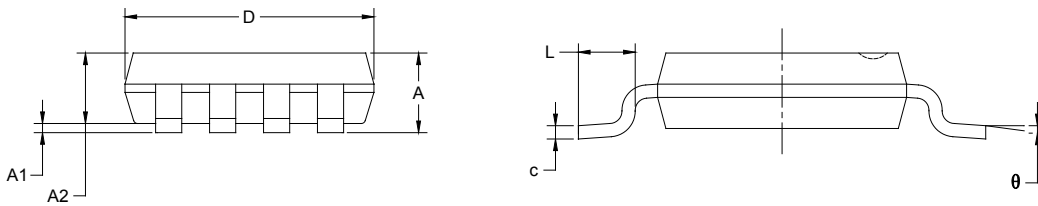

Symbol	Dimensions In Millimeters		Dimensions In Inches	
	MIN	MAX	MIN	MAX
A	0.820	1.100	0.032	0.043
A1	0.020	0.150	0.001	0.006
A2	0.750	0.950	0.030	0.037
b	0.250	0.380	0.010	0.015
c	0.090	0.230	0.004	0.009
D	2.900	3.100	0.114	0.122
E	2.900	3.100	0.114	0.122
E1	4.750	5.050	0.187	0.199
e	0.650 BSC		0.026 BSC	
L	0.400	0.800	0.016	0.031
θ	0°	6°	0°	6°

TAPE AND REEL INFORMATION

REEL DIMENSIONS



TAPE DIMENSIONS



NOTE: The picture is only for reference. Please make the object as the standard.

KEY PARAMETER LIST OF TAPE AND REEL

Package Type	Reel Diameter	Reel Width W1 (mm)	A0 (mm)	B0 (mm)	K0 (mm)	P0 (mm)	P1 (mm)	P2 (mm)	W (mm)	Pin1 Quadrant
SOIC-8	13"	12.4	6.40	5.40	2.10	4.0	8.0	2.0	12.0	Q1
MSOP-8	13"	12.4	5.20	3.30	1.50	4.0	8.0	2.0	12.0	Q1

DD0001

PACKAGE INFORMATION

CARTON BOX DIMENSIONS



NOTE: The picture is only for reference. Please make the object as the standard.

KEY PARAMETER LIST OF CARTON BOX

Reel Type	Length (mm)	Width (mm)	Height (mm)	Pizza/Carton
13"	386	280	370	5

DD0002