

2 Cell / 3 Cell Narrow VDC Charger with SMBus Interface

BD99950MUV

General Description

The BD99950MUV is a high-efficiency, synchronous Narrow VDC system voltage regulator and battery charger controller. It has two charge pumps which separately drive N-channel MOSFETs for automatic system power source selection. Charge voltage, charge current, AC adapter current and minimum system voltage can be programmed through SMBus. With a small inductor, PWM switching frequency can also be programmed by SMBus up to 1.2MHz.

Features

- N-channel MOSFETs available for Battery or Adapter Selection via Internal Charge Pumps
- Fast DPM Transient Response under Turbo Mode(<100μs)
- Linear Mode Trickle Charge via BGATE Charge Pump
- Low Operating Current BGATE Charge Pump at 17μA(typical)
- MLCC Output Capacitor
- High Light Load Efficiency for Energy Star and ErP Lot6
- Fast Load Current Transient Response under No Battery or Dead Battery conditions
- NMOS-NMOS Synchronous Step-Down Controller
- Programmable 600kHz-1.2MHz Switching Frequency
- Programmable Charge Voltage (16mV resolution), Charger Current (64mA resolution), Input Current (64mA resolution), Minimum System Voltage (64mV resolution)
- ±0.5% Charge Voltage Accuracy
- ±3% Charge Current Accuracy
- ±3% Input Current Accuracy
- ±0.5% Minimum System Voltage Accuracy
- ±2% 20x Input Current Amplifier Output Accuracy
- Integrated Loop Compensation
- Battery Learn Function
- AC Adapter Operating Range: 6.0V to 24.0V
- Off-State Battery Discharge Current at 15μA
- 20pin 3.5mm×3.5mm QFN Package

Applications

- Ultrabook, Notebook PC, Ultra-mobile PC, Tablet PC

Key Specifications

- Input Voltage Range: 6.0V to 24.0V
- Output Voltage Range: 3.072V to 16.384V
- Charge Voltage Accuracy: ±0.5%
- Switching Frequency: 600kHz to 1.2MHz
- Battery Standby Current: 17μA (Typ)
- Operating Temperature Range: -10°C to +85°C

Structure

Silicon Monolithic Integrated Circuit

Package

W(Typ) x D(Typ) x H(Max)
 VQFN20PV3535 3.50mm x 3.50mm x 1.00mm

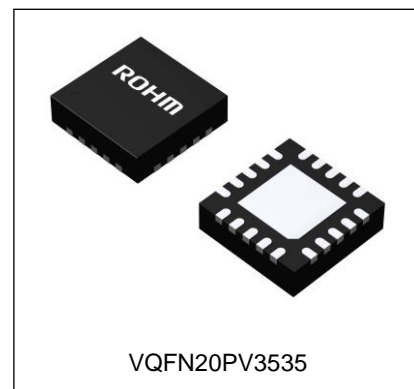

Typical Application Circuit

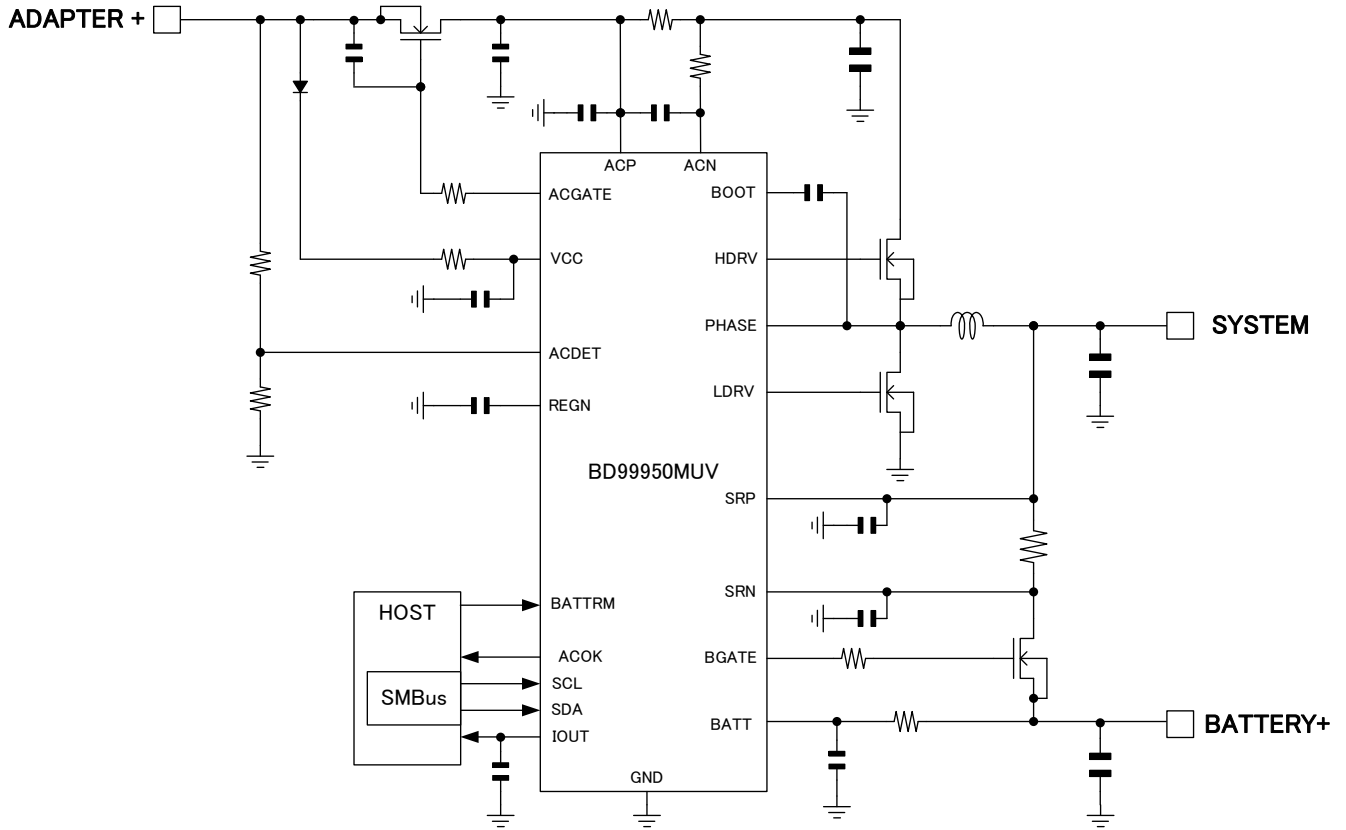
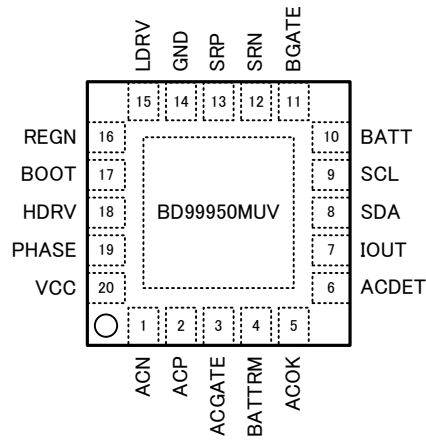

Figure 1. Typical Application Circuit

Pin Configuration (TOP VIEW)



Pin Descriptions

Pin No.	Pin Name	Function	Range	I/O
1	ACN	Input current sense resistor negative input. Place a 1 μ F ceramic capacitor from ACN to ACP for common-mode filtering.	0V to Adapter	I
2	ACP	Input current sense resistor positive input. Place a 0.1 μ F ceramic capacitor from ACP to GND for common-mode filtering.	0V to Adapter	I
3	ACGATE	Charge pump output to drive adapter input n-channel MOSFETs. The ACDRV voltage is 6V above VCC during AC adapter insertion. Place a 5.1k Ω resistor and a 0.01 μ F capacitor to ground as a low pass filter to limit inrush current.	0V to Adapter + 6V	O
4	BATTRM	Battery removal signal input When battery is removed, BGATE charge pump turns off. A high level indicates that the battery was removed.	0V to 5V	I
5	ACOK	AC adapter voltage detection open drain output. The internal open drain NMOS turns off when ACDET pin voltage is between 2.4V and 3.15V.	0V to 30V	O
6	ACDET	AC adapter voltage detection input. Valid AC adapter input range is set using resistors forming a voltage divider which are connected between ACDET & GND and ACDET & AC adapter.	0V to 5V	I
7	IOUT	Buffered adapter or charge current output selectable with SMBus command. The IOUT voltage is 20 times the voltage in the sense resistor. Place a 0.1 μ F or less ceramic decoupling capacitor from IOUT pin to GND.	0V to 5V	O
8	SDA	SMBus open-drain data I/O. Connect to SMBus data line from the host controller or smart battery Connect a 10k Ω pull-up resistor according to SMBus specifications.	0V to 5V	I/O
9	SCL	SMBus open-drain clock input. Connect to SMBus clock line from the host controller or smart battery Connect a 10k Ω pull-up resistor according to SMBus specifications.	0V to 5V	I
10	BATT	Battery voltage input. Connect a 510 Ω resistor to the source of the n-channel MOSFET. Place a 0.1 μ F ceramic capacitor from BATT to GND.	0V to Battery	I
11	BGATE	Charge pump output to drive BATT to SRN n-channel MOSFET. BATDRV voltage must be 6V above BATT to turn on n-channel MOSFET. Connect a 510 Ω resistor to the gate of the n-channel MOSFET.	0V to Battery + 6V	O
12	SRN	Charge current sense resistor negative input. Place a 0.1 μ F ceramic capacitor from SRN to GND for common-mode filtering.	0V to Battery	I
13	SRP	Charge current sense resistor positive input. Place a 0.1 μ F ceramic capacitor from SRP to GND for common-mode filtering.	0V to Battery	I
14	GND	IC ground.	0V	I
15	LDRV	Low-side power MOSFET driver output. Connect this pin to the gate of the low-side n-channel MOSFET.	0V to 6V	O
16	REGN	Linear regulator output. REGN is the output of the 5.25V linear regulator supplied from VCC. Connect a 1 μ F ceramic capacitor from REGN to GND.	0V to 5.5V	O
17	BOOT	High-side power MOSFET driver power supply. Connect a 0.1 μ F capacitor from BOOT to PHASE.	0V to Adapter + 5V	I
18	HDRV	High-side power MOSFET driver output. Connect this pin to the gate of the high-side n-channel MOSFET.	-1V to Adapter + 5V	O
19	PHASE	High-side power MOSFET driver source. Connect this pin to the source of the high-side n-channel MOSFET.	-1V to Adapter	I
20	VCC	Input supply, diode OR from adapter. Place a 10 Ω resistor and 1 μ F capacitor to ground as a low pass filter to limit inrush current.	0V to Adapter	I
PAD	PAD	Connect to ground	0V	-

Block Diagram

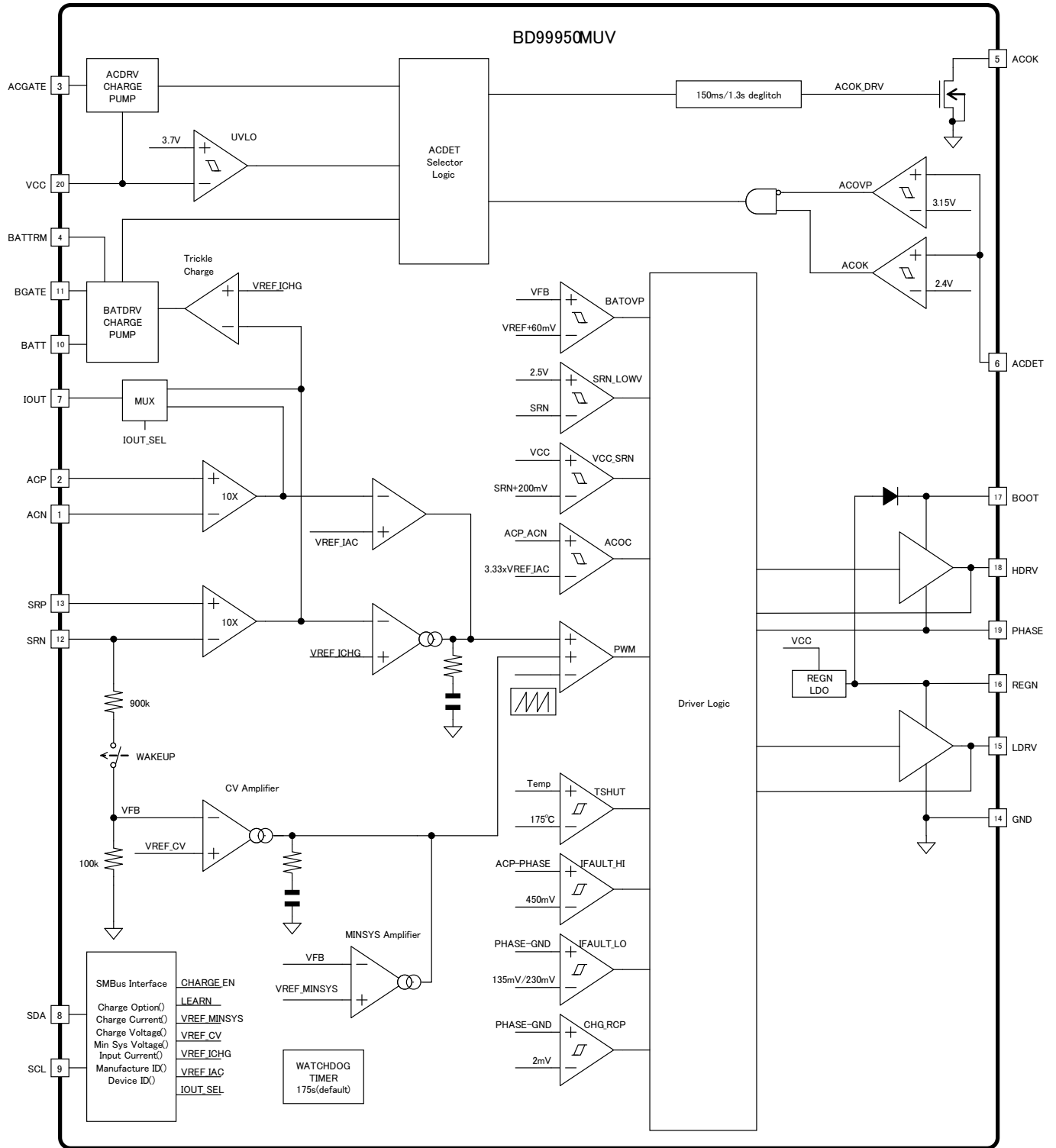

Figure 2. Block Diagram

Absolute Maximum Ratings (over operating free-air temperature range (unless otherwise noted))

Parameter	Rating	Unit	Conditions
VCC, BATT, SRN, SRP	-0.3 to 30.0	V	
ACN, ACP	-0.3 to 40.0	V	
PHASE	-2.0 to ACN+0.3	V	
ACGATE, BGATE, BOOT	-0.3 to 35.0	V	
HDRV	PHASE-0.3 to BOOT+0.3	V	
IOUT, LDRV	-0.3 to REGN+0.3	V	
BATTRM, ACDET, SDA, SCL, REGN, ACOK, PHASE-BOOT	-0.3 to 6.0	V	
VCC-ACGATE, BATT-BGATE	-0.3 to 7.0	V	
ACP-ACN, SRP-SRN	-0.3 to 0.3	V	
Power Dissipation	1.64	W	Board dimension: 114.3mm x 76.2mm x 1.6mm Surface Copper area: 2.25mm ² 2nd and 3rd Copper area: 5505mm ² Ta over 25 °C, subtracts 16.4mW/°C
Junction Temperature Range(Tj)	-20 to 125	°C	
Storage Temperature Range (Tstg)	-55 to 150	°C	

Caution: Operating the IC over the absolute maximum ratings may damage the IC. In addition, it is impossible to predict all destructive situations such as short-circuit modes, open circuit modes, etc. Therefore, it is important to consider circuit protection measures, like adding a fuse, in case the IC is operated in a special mode exceeding the absolute maximum ratings

Recommended Operating Conditions (over operating free-air temperature range (unless otherwise noted))

Parameter	Symbol	Min	Typ	Max	Unit
Adapter Voltage	ADAPTER+	6.0	18.0	24.0	V
Output Voltage	SYSTEM	3.0	-	17.0	V
Battery Voltage (With Adapter Mode)	BATTERY+	0.0	-	17.0	V
Battery Voltage (Only Battery Mode)	BATTERY+	5.4	-	17.0	V
Operating Temperature Range (Ta)	Topr	-10	-	85	°C

(Note 3) Pd, ASO should not be exceeded

Electrical Characteristics

(VCC/ACP/ACN = 18.0V, BATT/SRP/SRN = 7.4V, PHASE = 0.0V, GND = 0V Ta=25 °C (unless otherwise specified))

Parameter	Symbol	Min	Typ	Max	Unit	Conditions
Adapter Standby Current	IADP	-	1.0	1.5	mA	ACDET=0V
Battery Standby Current 1 (VACDET=0.0V)	IBATT1	-	17.0	30.0	μA	BGATE Charge Pump ON
Battery Standby Current 2 (VACDET=0.0V, VBATTRM=3.3V)	IBATT2	-	15.0	25.0	μA	BGATE Charge Pump OFF
Battery Current (VVCC=18.0V)	IBATT3	-	-	240	μA	
Switching Frequency 1	FOSC1	510	600	690	kHz	Charge Option[10:9] = 00
Switching Frequency 2	FOSC2	720	800	880	kHz	Charge Option[10:9] = 01
Switching Frequency 3	FOSC3	850	1000	1150	kHz	Charge Option[10:9] = 10
Switching Frequency 4	FOSC4	1020	1200	1380	kHz	Charge Option[10:9] = 11
REGN Output Voltage	VREGN	4.9	5.2	5.5	V	
SMBus Operation Frequency	FSMB	10	-	400	kHz	
Charge Voltage						
Charge Voltage Accuracy1 (SRN Terminal Voltage)	VCV1	8.358	8.400	8.442	V	Charge Voltage() = 0x20D0
Charge Voltage Accuracy2 (SRN Terminal Voltage)	VCV2	12.516	12.592	12.667	V	Charge Voltage() = 0x3130

Electrical Characteristics – continued

Parameter	Symbol	Min	Typ	Max	Unit	Conditions
Charge Current						
Charge Current Accuracy (10mΩ current sense resistor)	I _{CHG1}	3973	4096	4219	mA	Charge Current() = 0x1000
	I _{CHG2}	1946	2048	2150	mA	Charge Current() = 0x0800
	I _{CHG3}	921	1024	1126	mA	Charge Current() = 0x0200
	I _{CHG4}	172	256	340	mA	Charge Current() = 0x0100
	I _{CHG5}	-	192	-	mA	Charge Current() = 0x0140
	I _{CHG6}	64	128	192	mA	Charge Current() = 0x0080
Trickle Charge Current (10mΩ current sense resistor, BATT < Minimum System Voltage)	I _{CHGTRI}	-	256	-	mA	Charge Current() = 0x0800
Trickle Charge to Fast Charge Detect Threshold	I _{CHGTH}	-	-180	-	mA	Below Trickle Charge Current
Input Current						
Adapter Current Accuracy (20mΩ current sense resistor)	I _{ADP1}	3973	4096	4219	mA	Input Current() = 0x1000
	I _{ADP2}	1946	2048	2150	mA	Input Current() = 0x0800
	I _{ADP3}	870	1024	1178	mA	Input Current() = 0x0400
	I _{ADP4}	384	512	640	mA	Input Current() = 0x0200
Minimum System Voltage						
Minimum System Voltage Accuracy (SRN Terminal Voltage)	V _{MINSYS1}	6.113	6.144	6.175	V	Minimum System Voltage() =0x1800<default at POR>
IOUT Amplifier						
IOUT Terminal Voltage Accuracy	G _{IOUT}	-	20.0	-	V/V	(V _{IOUT})/(V _{ACP} - V _{ACN})
	V _{IOUT1}	802.8	819.2	835.6	mV	(V _{ACP} - V _{ACN})=40.96mV
	V _{IOUT2}	174.1	204.8	235.5	mV	(V _{ACP} - V _{ACN})=10.24mV
Comparator						
ACOK Comparator	V _{ACOK1}	2.376	2.400	2.424	V	ACDET rising for 19V Adapter
ACOK Comparator Hysteresis	V _{ACOK2}	-	50	-	mV	ACDET falling
ACOV _P Comparator	V _{ACOV_P1}	3.050	3.150	3.250	V	ACDET rising
ACOV _P Comparator Hysteresis	V _{ACOV_P2}	-	75	-	mV	ACDET falling
VCC UVLO (L to H)	V _{UVLO1}	3.5	3.7	3.9	V	VCC rising
VCC UVLO Hysteresis	V _{UVLO2}	-	300	-	V	VCC falling
VCC to SRN Comparator	V _{VCCOK1}	-	200	-	mV	VCC rising above SRN
VCC to SRN Comparator Hysteresis	V _{VCCOK2}	-	100	-	mV	VCC falling toward SRN
High Side FET OCP	V _{HOC_P}	200	450	900	mV	ACP to PHASE
Low Side FET OCP 1	V _{LOC_P1}	70	135	220	mV	Charge Option[7] = 0 PHASE to GND
Low Side FET OCP 2	V _{LOC_P2}	140	230	340	mV	Charge Option[7] = 1 PHASE to GND
SRN OVP	V _{OV_P}	300	600	900	mV	Above Charge Voltage
Power Select N-Channel FET Gate Driver						
VCC to ACGATE Voltage	V _{ACGATE}	5.0	6	6.5	V	V _{ACGATE} – V _{VCC}
ACGATE Discharge Resistor	R _{ACGATE}	-	2	5	kΩ	
BATT to BGATE Voltage	V _{BGATE}	5.0	6	6.5	V	V _{BGATE} – V _{BATT}
BGATE Discharge Resistor	R _{BGATE}	-	250	500	Ω	

Electrical Characteristics – continued

Switching Driver						
BOOT Terminal Current	I_{BOOT}	-	50	-	μA	
HDRV PMOS ON Resistance	$R_{HDRV P}$	-	6.0	10.0	Ω	$I_D = -10\text{mA}$
HDRV NMOS ON Resistance	$R_{HDRV N}$	-	0.65	1.3	Ω	$I_D = 10\text{mA}$
LDRV PMOS ON Resistance	$R_{LDRV P}$	-	7.5	12.0	Ω	$I_D = -10\text{mA}$
LDRV NMOS ON Resistance	$R_{LDRV N}$	-	0.9	1.4	Ω	$I_D = 10\text{mA}$
Dead Time	T_{DEAD}	-	30	-	ns	
Others						
BATTRM Input H	V_{INH}	2.5	-	5.5	V	
BATTRM Input L	V_{INL}	0.0	-	0.3	V	
BATTRM Pull Down Resistor	R_{PD}	-	500	-	$\text{k}\Omega$	
ACOK Leak Current	I_{ACOKLK}	-1.0	0.0	1.0	μA	

Typical Performance Curves (Adapter = 19V, 2S2P Li-Battery, Ta = +25°C (unless otherwise specified.))

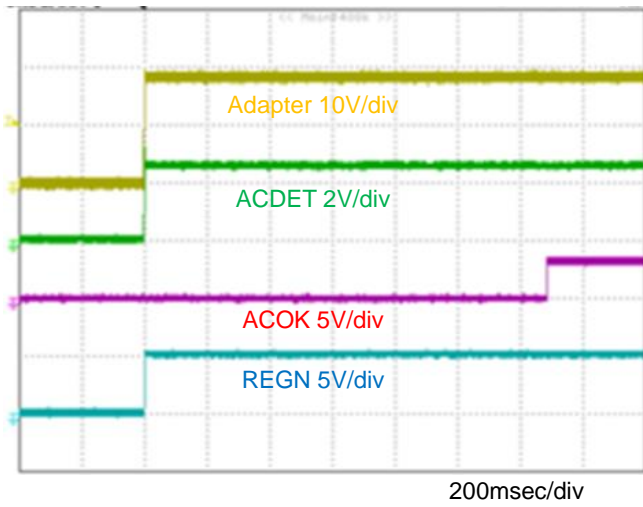

Figure 3. Adapter Insert to ACOK

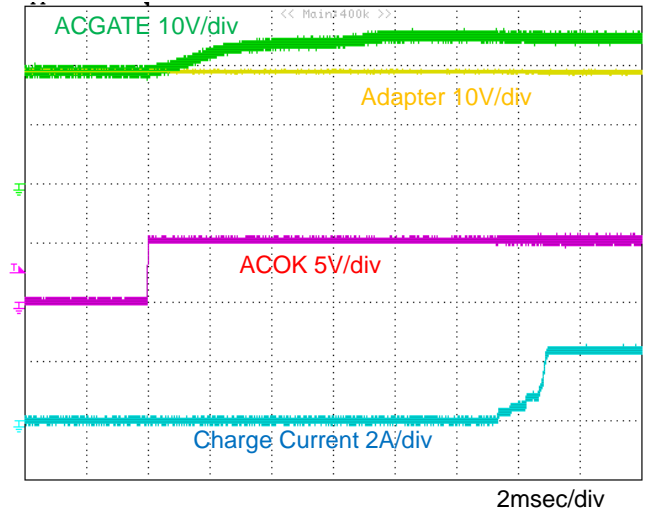

Figure 4. ACOK to Charge Start

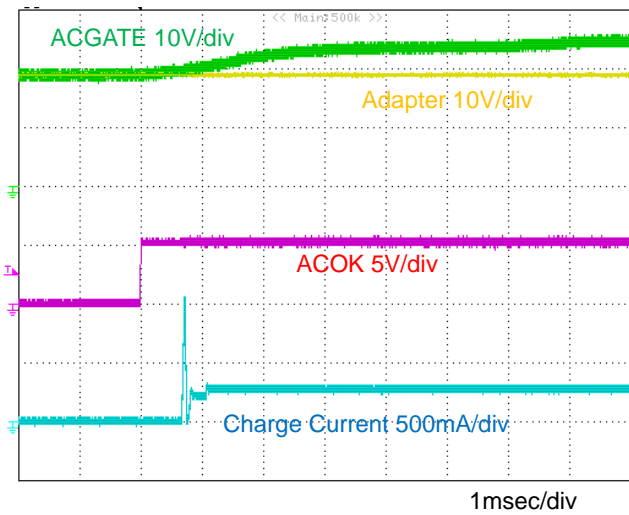

Figure 5. ACOK to Trickle Charge Start

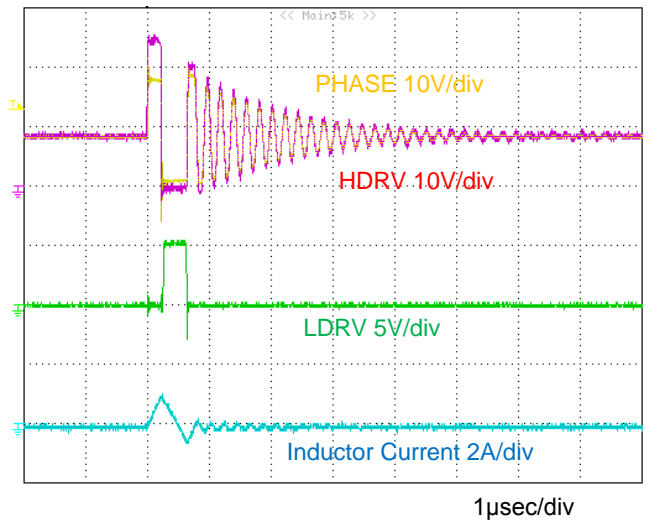

Figure 6. SLLM (Variable Frequency) Mode Light Load Switching Waveform

Typical Performance Curves - continued

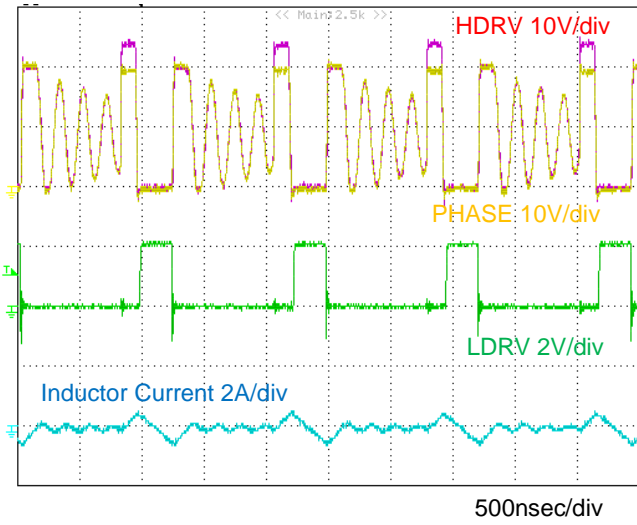

Figure 7. Fixed Frequency Mode Light Load Switching Waveform

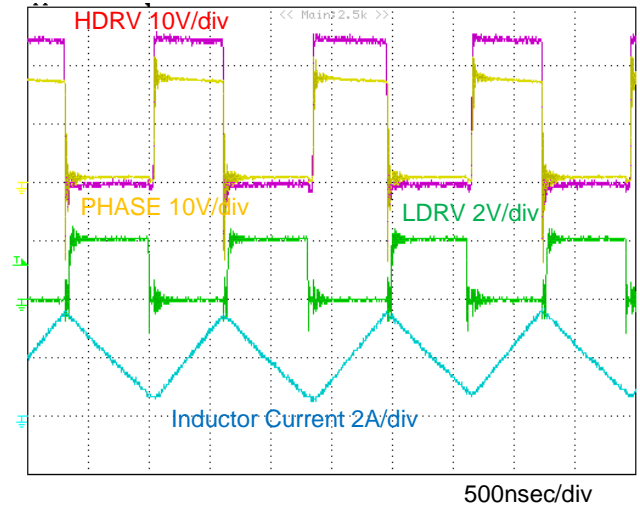

Figure 8. Continuous Conduction Mode Switching Waveform

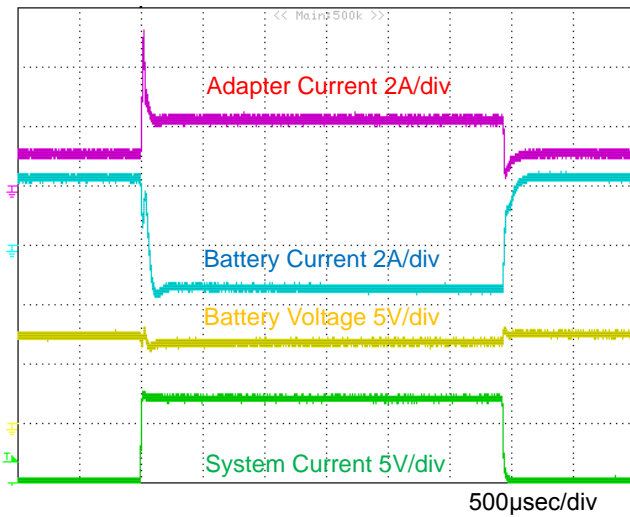

Figure 9. System Current Load Transient (Input DPM and Battery Discharging)

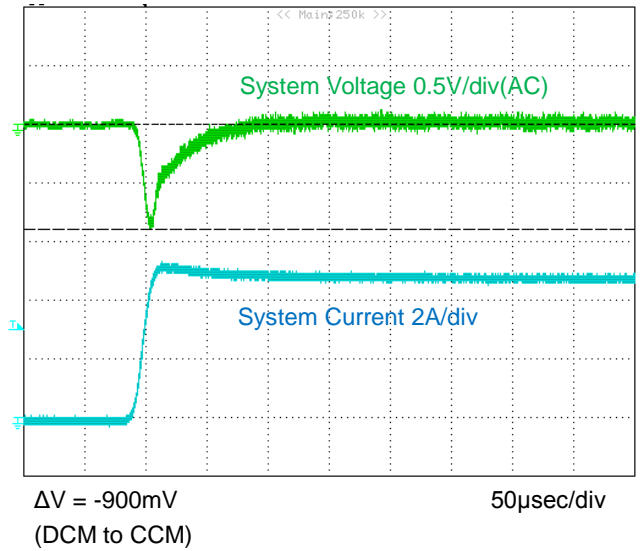

Figure 10. No-Battery System Current Load Transient (0A to 5A)

Typical Performance Curves - continued

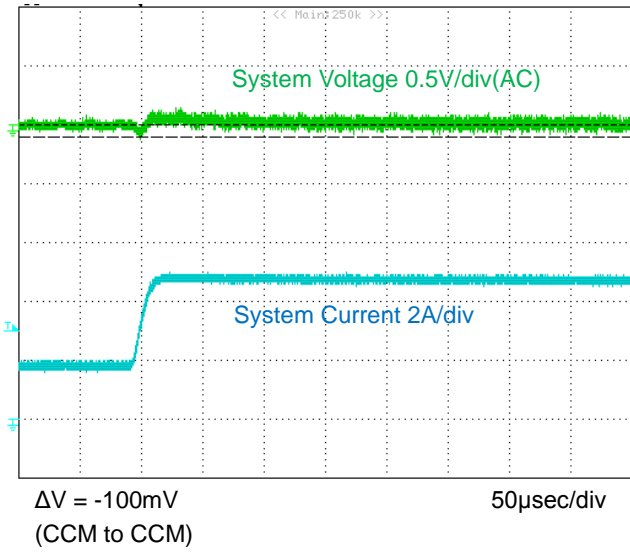

Figure 11. No-Battery System Current Load Transient (2A to 5A)

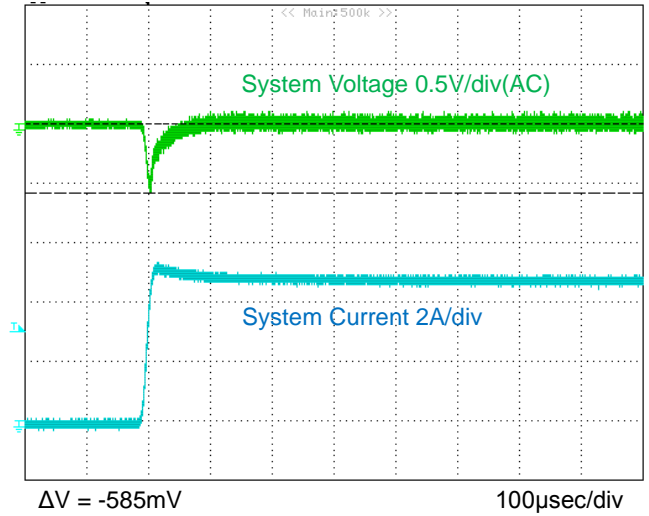

Figure 12. Trickle Charge Mode System Current Transient (0A to 5A)

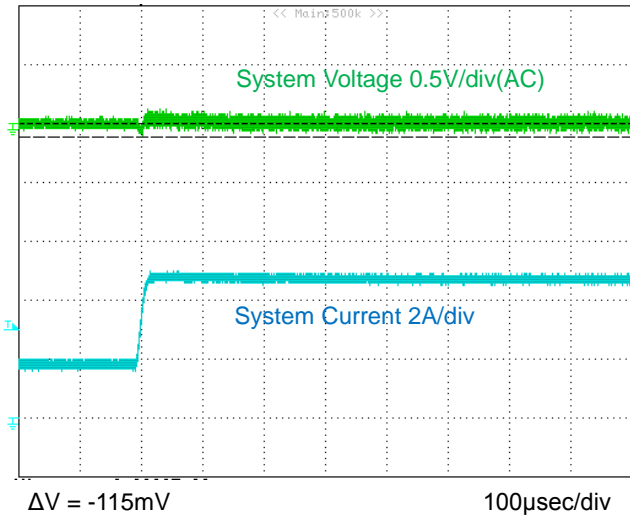

Figure 13. Trickle Charge Mode System Current Transient (2A to 5A)

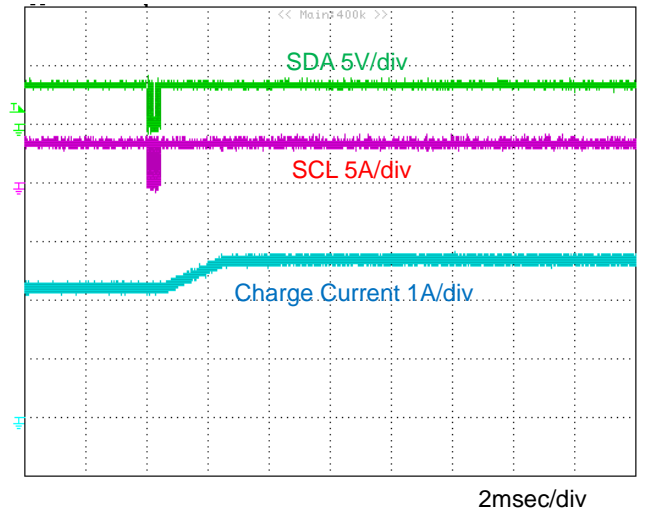

Figure 14. Charge Current Setting Change (2.560A to 3.072A)

Typical Performance Curves - continued

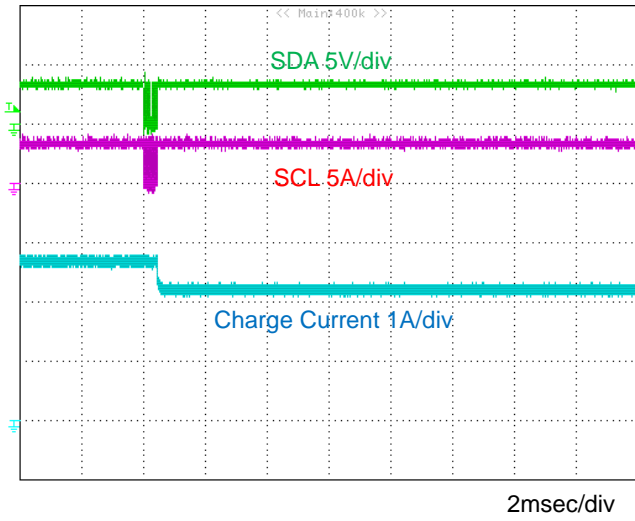

Figure 15. Charge Current Setting Change (3.072A to 2.560A)

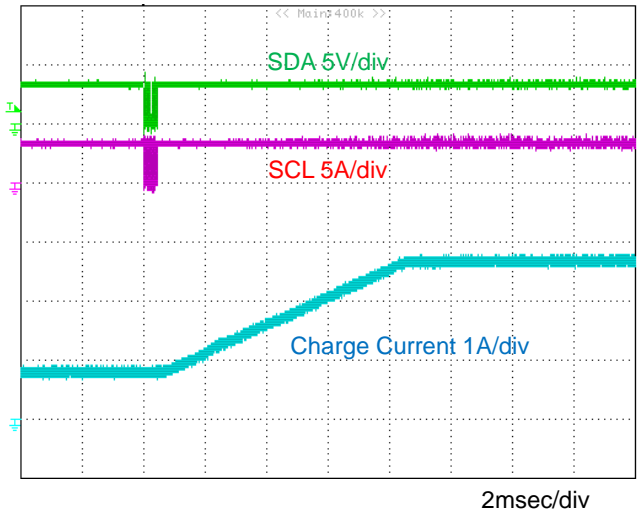

Figure 16. Charge Current Setting Change (1.024A to 3.072A)

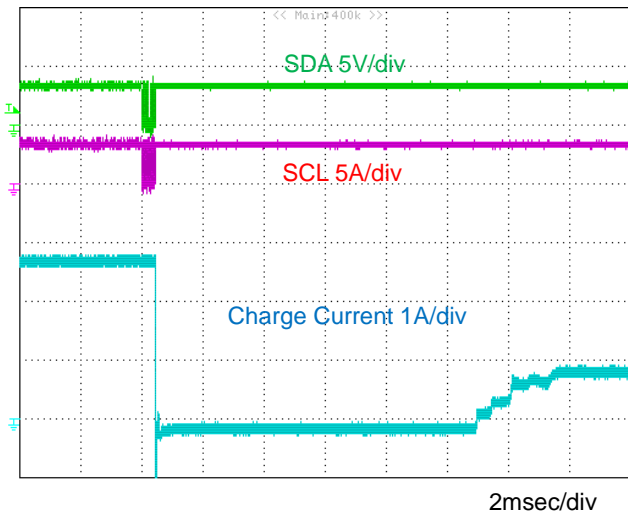

Figure 17. Charge Current Setting Change (3.072A to 1.024A)

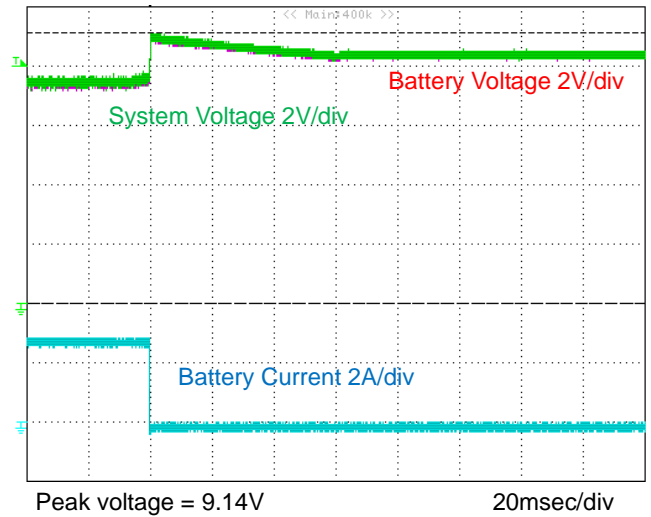

Figure 18. Battery Removed

Typical Performance Curves - continued

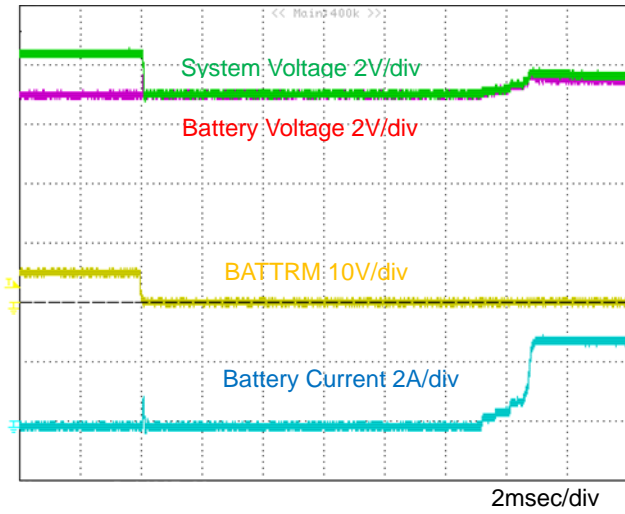

Figure 19. Battery Insertion
(BATTRM=H to L or Charge Option[11]=1 to 0)

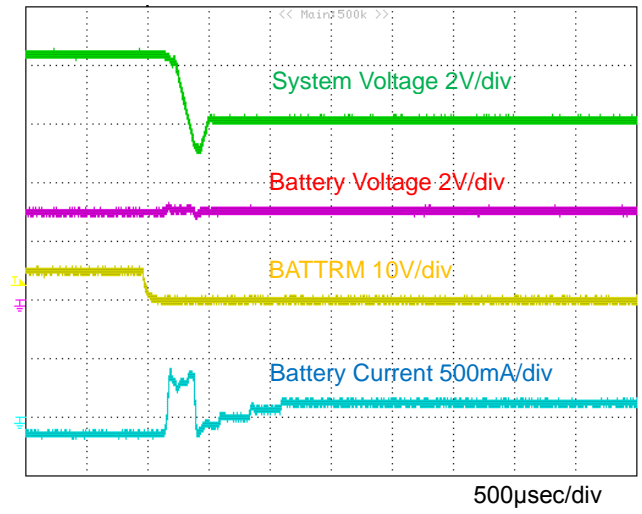

Figure 20. Low Battery Insertion
(BATTRM =H to L or Charge Option[11]=1 to 0)

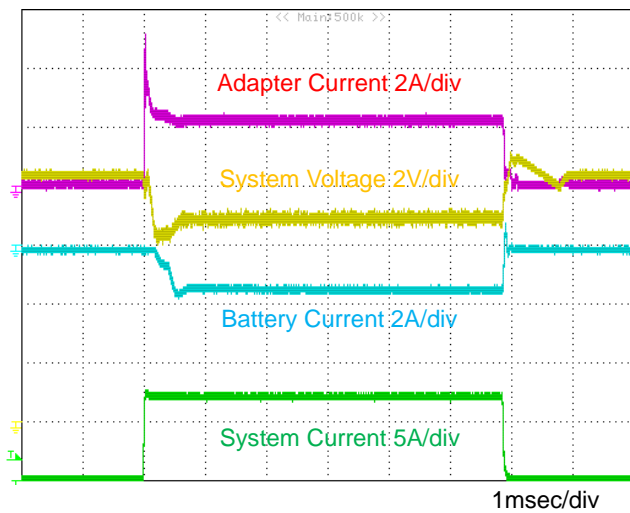

Figure 21. System Current Load Transient
(Fully Charged Battery 0x14=0000)

Typical Performance Curves - continued

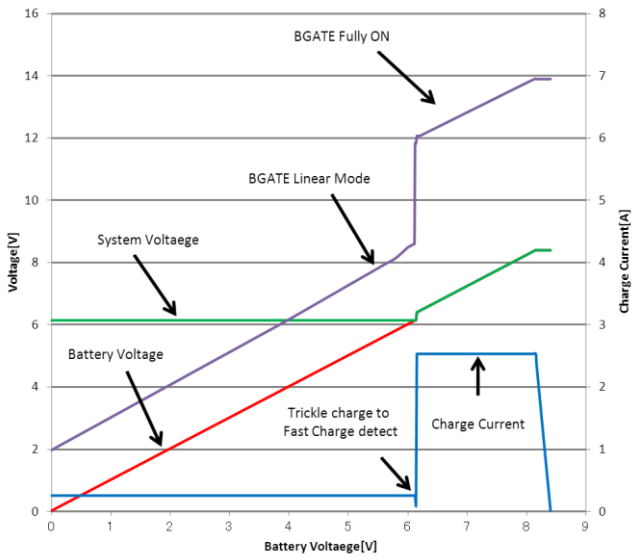

Figure 22. Battery Voltage vs. Charge Current

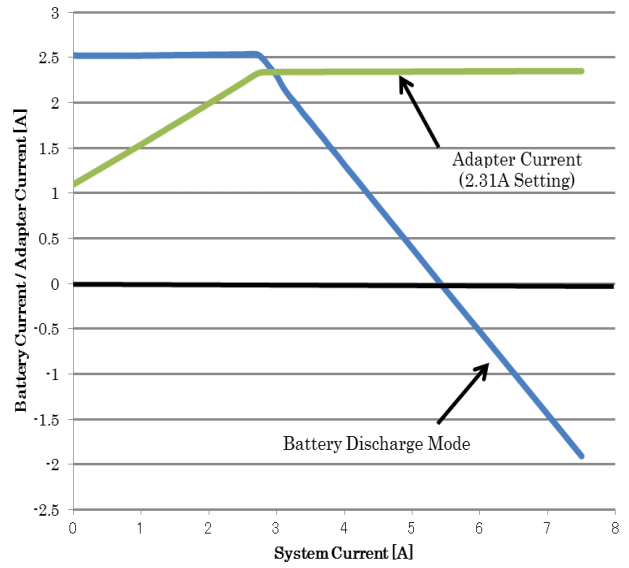

Figure 23. System Current vs. Adapter Current / Charge Current

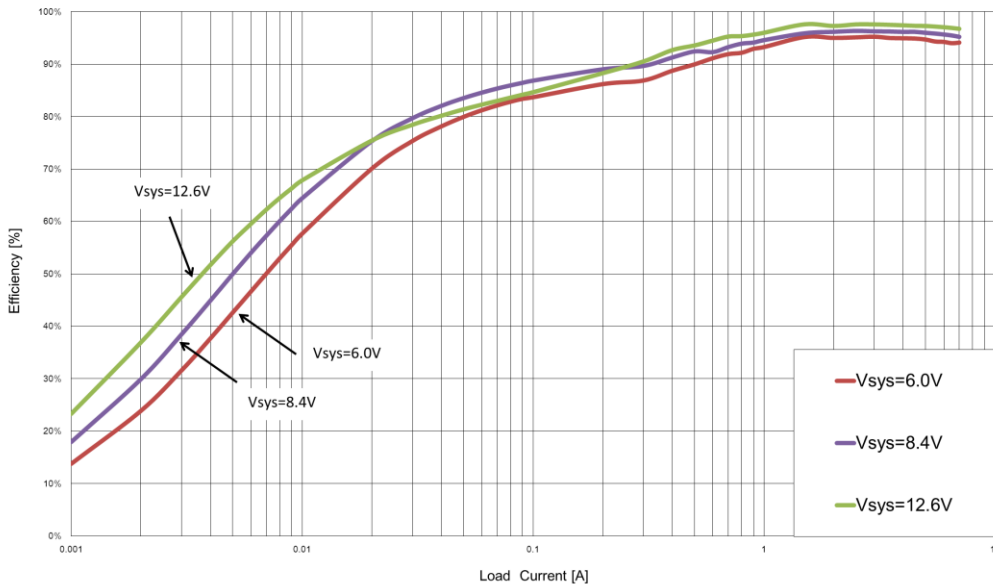

Fig.24 SLLM Mode Output Current vs. Efficiency

Operating Description

○ SMBus Protocols

Write – Word Format

S	SLAVE ADDRESS	W	A	REGISTER ADDRESS	A	LOW DATA BYTE	A	HIGH DATA BYTE	A	P
	7bits	1bit	1bit	8bits	1bit	8bits	1bit	8bits	1bit	
	0b 0001001	0	0	MSB LSB	0	MSB LSB	0	MSB LSB	0	

0x12H Charge Option
 0x14H Charge Current
 0x15H Charge Voltage
 0x3EH Minimum System Voltage
 0x3FH Adapter Current

Read – Word Format

S	SLAVE ADDRESS	W	A	REGISTER ADDRESS	A	S	SLAVE ADDRESS	R	A	LOW DATA BYTE	A	HIGH DATA BYTE	N	P
	7bits	1bit	1bit	8bits	1bit		7bits	1bit	1bit	8bits	1bit	8bits	1bit	
	0b 0001001	0	0	MSB LSB	0		0b 0001001	1	0	MSB LSB	0	MSB LSB	1	

0x12H Charge Option
 0x14H Charge Current
 0x15H Charge Voltage
 0x3EH Minimum System Voltage
 0x3FH Adapter Current
 0xFEH Manufacture ID
 0xFFH Device ID

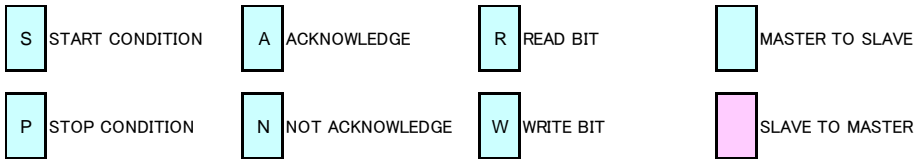

○ SMBus Communication Timing Waveforms

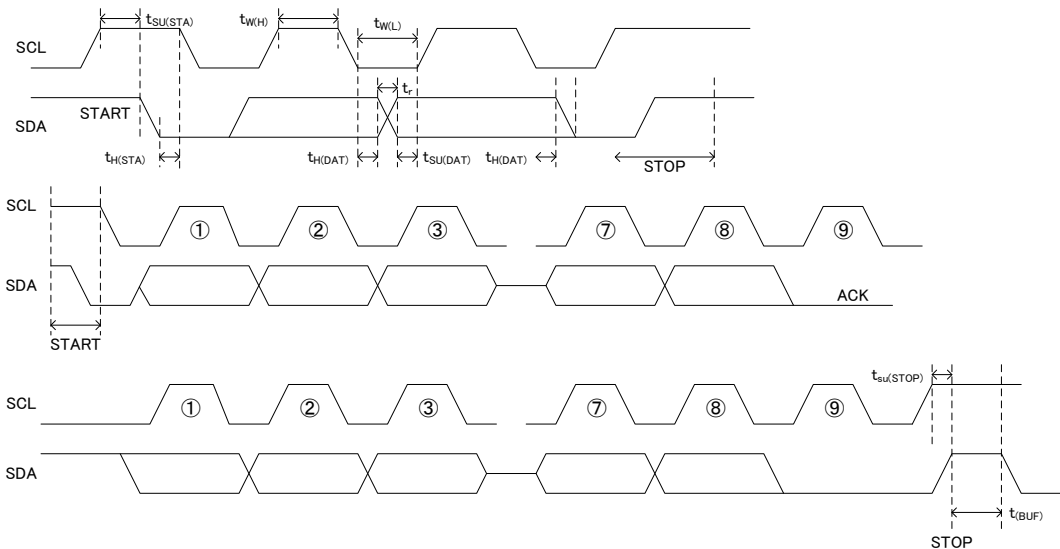

SMBus Timing Specification

Parameter	Symbol	Min	Typ	Max	Unit	Condition
SMBus Frequency	F _{SMBus}	10	-	400	kHz	
SDA/SCL Input Low Voltage	V _{INL}	0.0	-	0.8	V	
SDA/SCL Input High Voltage	V _{INH}	2.1	-	5.5	V	
SDA Hold Time from SCL	T _{H(DAT)}	250	-	-	ns	
SDA Setup Time from SCL	T _{SU(DAT)}	300	-	-	ns	
Start Condition Hold Time from SCL	T _{H(STA)}	4	-	-	μs	
Start Condition Setup Time from SCL	T _{SU(STA)}	4.7	-	-	μs	
Stop Condition Setup Time from SCL	T _{SU(STOP)}	4	-	-	μs	
Bus Free Time	T _{BUF}	4.7	-	-	μs	
SCL Low Timeout	T _{TO(SCL)}	-	25	-	ms	
Watch Dog Timer	T _{WDI}	140	175	220	s	

○ SLAVE Device Address of BD99950MUV

Table 1.

SLAVE ADDRESS + R	0b00010011	(0x13)H
SLAVE ADDRESS + W	0b00010010	(0x12)H

○ Battery Charger Command

The BD99950MUV supports the following 7 registers:

Table 2.

REGISTER ADDRESS	REGISTER NAME	READ/WRITE	DESCRIPTION	POR STATE
0x12H	Charge Option	Read or Write	Charge Option	0xF302H
0x14H	Charge Current	Read or Write	7-bit Charge Current Setting	0x0000H
0x15H	Charge Voltage	Read or Write	11-bit Charge Voltage Setting	0x2000H(8.192V)
0x3EH	Minimum System Voltage	Read or Write	6-bit Minimum System Voltage Setting	0x1800H(6.144V)
0x3FH	Input Current	Read or Write	7-bit Input Current Setting	0x0800H(2.048A)
0xFEH	Manufacturer ID	Read Only	Manufacturer ID	0x001FH
0xFFH	Device ID	Read Only	Device ID	0x0001H

○ Enable of Charge

The conditions which make SMBus communication possible are as follows:

- ① REGN voltage is above 4.0V.
- ② VCC voltage is above 5.0V.

When all conditions are not satisfied, reset will occur and register settings will return to their POR states.

○ Battery Discharge Assistant Function when System Power Supply is more than AC adapter power

When the system load requires power more than what the AC adapter can provide due to the Turbo-Boost function of the CPU while charging in CC or CV mode, power insufficiency can be compensated by a battery.

Also, charge current is set to 0mA when charging is complete and when it turns to Battery Discharge mode during which the external FET (Q4) of battery side is off, the BGATE terminal charge pump automatically activates and by turning on Q4, high efficiency discharge is achieved.

When Charge Option [11] is set to 1, the BGATE terminal charge pump continuously stays off.

○ ACOC Function

When more than 333% of the set AC adapter current is detected, HDRV terminal becomes low and the high-side FET turns off. Switching automatically starts when ACOC condition is released.

○ High-Side FET OCP Function

When PHASE voltage drops 450mV from the ACP voltage while HDRV voltage is high, over-current condition is detected and high-side FET turns off.

Upon destruction of the low-side FET, avoid using the protection circuit under normal operation.

- Low-Side FET OCP function

When PHASE voltage exceeds 135mV more than the ACP voltage while LDRV voltage is high, over-current condition is detected and low-side FET turns off.

Upon destruction of the high-side FET, avoid using the protection circuit under normal operation.
- Battery Over Voltage Protection(BATTOVP)

The system voltage rises when battery is suddenly disconnected while charging in CC mode. The SRN pin's OVP function is built-in to avoid over-voltage to be supplied to the system. The chip will not allow the high-side and low-side MOSFET to turn-on when the battery voltage at SRN exceeds 600mV more than the charge voltage set-point. If the chip detects SRN terminal OVP, the high-side FET and low-side FET are turned off.

Upon release from the OVP condition, it automatically returns to its normal state and restarts switching.
- Watchdog Timer

The BD99950MUV chip includes a watchdog timer to terminate charging if it does not receive a write command to the Charge Voltage() or Charge Current() registers within 175s. If a watchdog timeout occurs, all register values are left as is, however, charging is suspended. Charging also stops when SCL voltage stays low for more than 25ms since this signifies that the power supply may have turned off.

To reset the watchdog timer and resume charging, the write commands to the Charge Voltage() or Charge Current() registers must be resent.

The watchdog timer can also be disabled, or set to 44s, 88s or 175s via SMBus.
- LEARN Mode

The battery LEARN cycle can be activated via SMBus command using the Charge Option() bit[6]. Set the bit to 1 to enable the battery LEARN cycle and 0 to disable it. When the LEARN function is enabled while the AC Adapter is connected, the system power source switches to battery.

The LEARN function allows the battery to discharge in order to calibrate the battery gauge over a complete discharge/charge cycle. The controller automatically exits LEARN cycle when the battery voltage is below the set value of Minimum System Voltage(). The system then switches back to adapter input.
- ACOK and ACOVP Function

The BD99950MUV uses an ACOK comparator to determine the source of AC Adapter voltage. An external resistor voltage divider attenuates the AC adapter voltage before it goes to ACDET.

The AC adapter detect threshold should typically be programmed to a value greater than the maximum battery voltage, but lower than the maximum allowed AC adapter voltage.

The open drain ACOK output requires an external pull-up resistor to system digital rail for a high level. It can be pulled to external rail under the following conditions:

 - VCC Voltage > 5.0V
 - $2.4V < ACDET \text{ Voltage} < 3.15V$
 - VCC Voltage – SRN Voltage > 300mV

After the first IC power on reset, the ACOK rising edge delay is always 1.3s. Set the Charge Option() bit[15] to 0 to set the rise deglitch time to 150ms.

When the ACDET pin voltage is higher than 3.15V, it is considered as AC adapter over voltage. ACOK will be pulled low, and charging will be disabled. The ACGATE Charge Pump will be turned off to disconnect the high voltage AC adapter during ACOVP.

When ACDET pin voltage falls below 3.15V and above 2.4V, it is considered as the adapter voltage returning back to its normal voltage. ACOK will be pulled high by an external pull up resistor.
- Transition from Trickle Charge mode to Fast Charge mode

Transition from trickle charge to CC charge (fast charge mode) occurs by detecting the decrease in trickle charge current. When the trickle charge current drops to less than 100mA from its set value, it automatically switches to CC charge (fast charge). To enable the transition to fast charge, the charge current must be set to more than 256mA.

- Charge OCP
When the charging current exceeds 100mA more than the set charge current, the DAC and charger restart to protect the battery from over current.
- Over Charge Voltage Setting Protection
When a write to the Charge Voltage() register is detected during CV charging mode, charging resets to protect battery from over-current.
- Setting Charge Options
The charge options are set by writing a valid 16-bit number to the charge option register. Each bit in the control register has a different function. Table 3 describes the function of each bit. Bits 2 and 4 are controlled internally and are read only.

Table 3. Charge Options Register (0x12H)

BIT	BIT NAME	DESCRIPTION
[15]	ACOK Deglitch Time Setting	0: ACOK rising edge deglitch time 150ms 1: ACOK rising edge deglitch time 1.3s <default at POR>
[14:13]	Watchdog Timer Setting	00: Disable Watchdog Timer 01: Enabled, 44 sec 10: Enabled, 88 sec 11: Enable Watchdog Timer (175s) <default at POR>
[12]	SLLM mode	0: Fixed Frequency Switching 1: Variable Frequency Switching(SLLM mode)<default at POR>
[11]	BGATE Charge Pump Enable	0: BGATE Charge Pump ON <default at POR> 1: BGATE Charge Pump OFF(from HOST when battery is removed)
[10:9]	Switching Frequency setting	00: 600kHz 01: 800kHz <default at POR> 10: 1MHz 11: 1.2MHz
[8]	High Side FET OCP Comparator Threshold Setting	0: function is disabled 1: 450mV <default at POR>
[7]	Low Side FET OCP Comparator Threshold Setting	0: 135mV <default at POR> 1: 230mV
[6]	LEARN Enable	0: Disable LEARN Cycle <default at POR> 1: Enable LEARN Cycle
[5]	IOUT Selection	0: IOUT is the 20x Adapter Current Amplifier Output <default at POR> 1: IOUT is the 20x Charge Current Amplifier Output
[4]	ACOK Indication (Read Only)	Adapter Detection Indicator 0: AC adapter is not present (ACDET < 2.4V) <default at POR> 1: AC adapter is present (ACDET > 2.4V)
[3]	Charge Over Current Protection	0: Charge Current DAC Reset and Charger Restart <default at POR> 1: Charge Current DAC Reset
[2]	Trickle Charge Indication (Read Only)	Trickle Charge Indicator 0: Charge in Switching Mode <default at POR> 1: In Trickle Charge mode(Linear charge mode)
[1]	ACOC Enable	0: ACOC Disable 1: 3.33x of Adapter Current Setting <default at POR>
[0]	Shut down	0: Enable NVDC Charger Control <default at POR> 1: Shut Down

○ Setting the Charge Voltage

The charge voltage is set by writing a valid 16-bit number to the Charge Voltage register. The first 4 LSBs are ignored and the next 11 bits are used to set the charge voltage through a DAC. The charge voltage range of the BD99950MUV is 3.072V to 16.384V. The register address for charge voltage is 0x15. The 16-bit binary number formed by D15-D0 represents the charge voltage set point in mV. However, the resolution becomes 16mV because the D0-D3 bits are ignored. The D15 bit is also ignored because it is not needed to span the 3.072V to 16.384V range.

Table 4. Charge Voltage Register (0x15H)

BIT	BIT NAME	DESCRIPTION
0	-	Not used
1	-	Not used
2	-	Not used
3	-	Not used
4	Charge Voltage, DACV 0	0 = Adds 0mV of charger voltage, 1024mV min 1 = Adds 16mV of charger voltage
5	Charge Voltage, DACV 1	0 = Adds 0mV of charger voltage, 1024mV min 1 = Adds 32mV of charger voltage
6	Charge Voltage, DACV 2	0 = Adds 0mV of charger voltage, 1024mV min 1 = Adds 64mV of charger voltage
7	Charge Voltage, DACV 3	0 = Adds 0mV of charger voltage, 1024mV min 1 = Adds 128mV of charger voltage
8	Charge Voltage, DACV 4	0 = Adds 0mV of charger voltage, 1024mV min 1 = Adds 256mV of charger voltage
9	Charge Voltage, DACV 5	0 = Adds 0mV of charger voltage, 1024mV min 1 = Adds 512mV of charger voltage
10	Charge Voltage, DACV 6	0 = Adds 0mA of charger voltage 1 = Adds 1024mV of charger voltage
11	Charge Voltage, DACV 7	0 = Adds 0mV of charger voltage 1 = Adds 2048mV of charger voltage
12	Charge Voltage, DACV 8	0 = Adds 0mV of charger voltage 1 = Adds 4096mV of charger voltage
13	Charge Voltage, DACV 9	0 = Adds 0mV of charger voltage 1 = Adds 8192mV of charger voltage
14	Charge Voltage, DACV 10	0 = Adds 0mV of charger voltage 1 = Adds 16384mV of charger voltage, 16384mV max
15	-	Not used.

○ Setting the Charge Current

The charge current is set by writing a valid 16-bit number to the Charge Current register. The first 6 LSBs are ignored and the next 7 bits are used to set the charge current through a DAC. The charge current range of the BD99950MUV is 128mA to 8.128A. The register address for charge current is 0x14. The 16-bit binary number formed by D15-D0 represents the charge current set point in mA. However, the resolution becomes 64mA because the D0-D5 bits are ignored. The D13-D15 bits are also ignored because they are not needed to span the 128mA to 8.128A range. To change “Trickle Charge” to “Fast Charge”, a setting of 256mA or higher is required.

Table 5. Charge Current Register (0x14H), Using 10mΩ Sense Resistor

BIT	BIT NAME	DESCRIPTION
0	-	Not used
1	-	Not used
2	-	Not used
3	-	Not used
4	-	Not used
5	-	Not used
6	Charge Current, DACI 0	0 = Adds 0mA of charger current 1 = Adds 64mA of charger current
7	Charge Current, DACI 1	0 = Adds 0mA of charger current 1 = Adds 128mA of charger current
8	Charge Current, DACI 2	0 = Adds 0mA of charger current 1 = Adds 256mA of charger current
9	Charge Current, DACI 3	0 = Adds 0mA of charger current 1 = Adds 512mA of charger current
10	Charge Current, DACI 4	0 = Adds 0mA of charger current 1 = Adds 1024mA of charger current
11	Charge Current, DACI 5	0 = Adds 0mA of charger current 1 = Adds 2048mA of charger current
12	Charge Current, DACI 6	0 = Adds 0mA of charger current 1 = Adds 4096mA of charger current, 8128mA max
13	-	Not used
14	-	Not used
15	-	Not used

○ Setting the Input Current

The input current is set by writing a valid 16-bit number to the Input Current register. The first 7 LSBs are ignored and the next 7 bits are used to set the input current through a DAC. The input current range of the BD99950MUV is 512mA to 6.144A. The register address for input Current is 0x3F. The 16-bit binary number formed by D15-D0 represents the input current set point in mA. However, the resolution becomes 64mA because the D0-D5 bits are ignored. The D13-D15 bits are also ignored because they are not needed to span the 512mA to 6.144A range. To set for more than 6.144A the sense resistor must be changed to 10mΩ.

Table 6. Input Current Register (0x3FH), Using 20mΩ Sense Resistor

BIT	BIT NAME	DESCRIPTION
0	-	Not used
1	-	Not used
2	-	Not used
3	-	Not used
4	-	Not used
5	-	Not used
6	Charge Current, DACS 0	0 = Adds 0mA of input current 1 = Adds 64mA of input current
7	Charge Current, DACS 1	0 = Adds 0mA of input r current 1 = Adds 128mA of input current
8	Charge Current, DACS 2	0 = Adds 0mA of input current 1 = Adds 256mA of input current
9	Charge Current, DACS 3	0 = Adds 0mA of input current 1 = Adds 512mA of input current
10	Charge Current, DACS 4	0 = Adds 0mA of input current 1 = Adds 1024mA of input current
11	Charge Current, DACS 5	0 = Adds 0mA of input current 1 = Adds 2048mA of input current
12	Charge Current, DACS 6	0 = Adds 0mA of input current 1 = Adds 4096mA of input current, 6144mA max
13	-	Not used
14	-	Not used
15	-	Not used

○ Setting the Minimum System Voltage

The minimum system voltage is set by writing a valid 16-bit number to the Minimum System Voltage register. The first 6 LSBs are ignored and the next 8 bits are used to set the minimum system voltage through a DAC. The minimum system voltage range of the BD99950MUV is 3.072V to 10.24V. The register address for Minimum System Voltage is 0x3E. The 16-bit binary number formed by D15-D0 represents the minimum system voltage set point in mV. However, the resolution becomes 64mV because the D0-D5 bits are ignored. The D14-D15 bits are also ignored because they are not needed to span the 3.072V to 10.24V range.

Table 7. Minimum System Voltage Register (0x3EH)

BIT	BIT NAME	DESCRIPTION
0	-	Not used
1	-	Not used
2	-	Not used
3	-	Not used
4	-	Not used
5	-	Not used
6	Charge Current, DACV 0	0 = Adds 0mV of minimum system voltage, 1024mV min 1 = Adds 64mV of minimum system voltage
7	Charge Current, DACV 1	0 = Adds 0mV of minimum system voltage, 1024mV min 1 = Adds 128mV of minimum system voltage
8	Charge Current, DACV 2	0 = Adds 0mV of minimum system voltage, 1024mV min 1 = Adds 256mV of minimum system voltage
9	Charge Current, DACV 3	0 = Adds 0mV of minimum system voltage, 1024mV min 1 = Adds 512mV of minimum system voltage
10	Charge Current, DACV 4	0 = Adds 0mA of minimum system voltage 1 = Adds 1024mV of minimum system voltage
11	Charge Current, DACV 5	0 = Adds 0mV of minimum system voltage 1 = Adds 2048mV of minimum system voltage
12	Charge Current, DACV 6	0 = Adds 0mV of minimum system voltage 1 = Adds 4096mV of minimum system voltage
13	Charge Current, DACV 7	0 = Adds 0mV of minimum system voltage 1 = Adds 8192mV of minimum system voltage, 10240mV max
14	-	Not used
15	-	Not used

External Components Selection

○ Inductor and Output Capacitor

Low ESR MLCC needs to be used to reduce ripple voltage. The inductance also has a great influence on ripple current which flows in the inductor. Ripple current that flows in inductor can be calculated using Formula (1). As shown in Formula (1), the bigger the coil is or the higher the switching frequency is, less ripple current flows.

$$\Delta I_L = \frac{(V_{CC} - V_{OUT}) \times V_{OUT}}{L \times V_{CC} \times f} \text{ [A]} \text{ (1)}$$

Ripple current must be 30-50% of the maximum output current.

$$\Delta I_L = 0.3 - 0.5 \times I_{OUTMAX} \text{ [A]}$$

$$L = \frac{(V_{CC} - V_{OUT}) \times V_{OUT}}{\Delta I_L \times V_{CC} \times f} \text{ [H]}$$

(ΔI_L : output ripple current f : switching frequency)

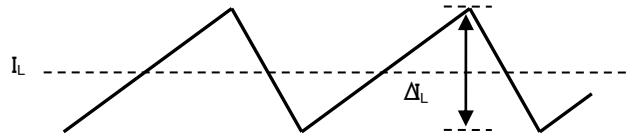

※Peak current must be set lower than the maximum current of the inductor. (Refer to inductor specification)

※In order to improve efficiency, lower DCR/ACR inductor is recommended.

※The increase of output ripple voltage may lower the charge current detection accuracy.

19V Adapter 2cell battery (fsw = 800kHz)

Adapter Capability	10W	20W	30W	40W
Max output Current	1.7A	3.4A	5.1A	6.8A
Inductor(μH)	4.7	3.3	3.3 or 2.2	2.2
Output Capacitor(μF)	22	33	44	44
SRP-SRN Sense Resistor(mΩ)	10	10	10	10

○ ACDET Resistor

An attenuated value of the AC adapter voltage is inputted to the ACDET pin using a voltage divider. Set the ACDET voltage so that the range is 2.4V to 3.15V when the AC adapter is inputted.

To lower the response speed of UVP and OVP due to noise in the AC adapter, insert capacitor C16 parallel to resistor R7 for filtering.

Example of setting

AC Adapter Voltage	10.5V	12V	15V	16V	19V	20V	24V
Battery	2cell	2cell	2cell/3cell	2cell/3cell	2cell/3cell	2cell/3cell	2cell/3cell
R6(Ω)	150k	180k	180k	200k	240k	240k	270k
R7(Ω)	51k	51k	39k	39k	39k	36k	33k
ACOK Voltage Rising Edge (typical)	9.5V	10.9V	13.5V	14.7V	17.2V	18.4V	22.0V
ACOV Voltage Rising Edge (typical)	12.4V	14.3V	17.7V	19.3V	22.5V	24.2V	29.0V

○ Reverse Input Protection Circuit

A protection circuit can be inserted (refer to Figure 26) in case the polarity of the AC adapter or the battery is reversed.

○ Switching Power MOSFET (Q1,Q2)

To decrease switching loss and to improve efficiency, select a FET with a small on-resistance and less gate capacity.

○ AC Adapter and Battery Pass Power MOSFET (Q3,Q4)

To decrease loss during operation, choose a FET with a small on-resistance.

- VCC Protection Filter when Inserting the AC Adapter
 Insert filter with 10Ω/1μF to prevent over-voltage caused by ringing when the AC adapter is inserted. ACP and ACN terminal are measured by increasing pressure of internal elements.

- ACN and ACP Differential Mode Noise Filtering
 When error is caused on the regulating current due to differential mode noise, insert a differential mode noise filter with 10Ω/1μF between the ACN and ACP pins.
 In this case, do not connect a capacitor between ACN and GND.

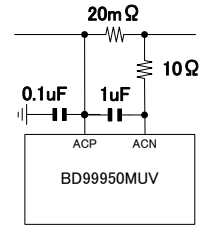

- SRP, and SRN Capacitor
 To prevent inaccuracies in current detection caused by common node noise, place a 0.1μF- 1μF capacitor as close as possible to the analog GND pin.

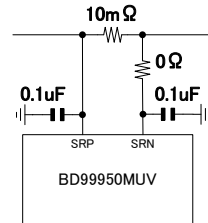

- Current Sensing Resistor
 During adapter hot plug-in, the parasitic inductance and the input capacitor from the adapter cable form a second order system. Thus adapter hot plug-in generate over voltage spike. The Voltage spike may be beyond IC Maximum Voltage and break the IC.
 As methods of solving for voltage spike, moving C1 capacitor between R1 and Q3.

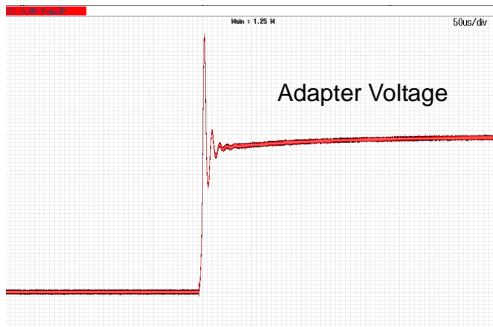
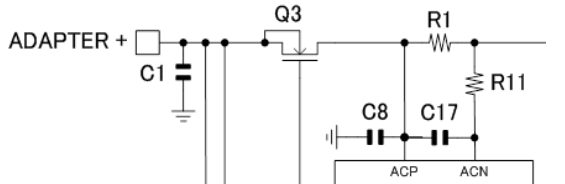

Adapter voltage when place input capacitor directry Adapter node and hot Plug-in

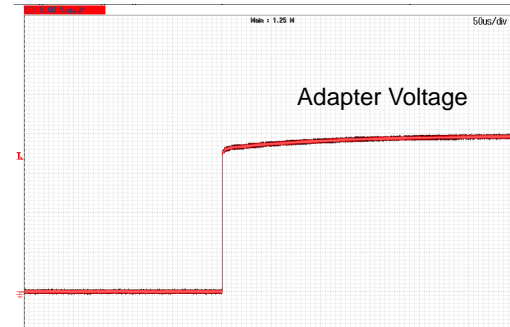
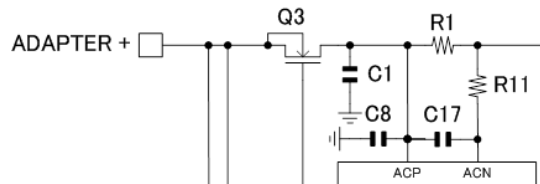

Adapter voltage when place C1 capacitor ACP node and hot Plug-in

PCB Layout Guideline

- Current Sensing Resistor
 The SRP/ACP and SRN/ACN connection must be laid out as shown in Figure 25.
 Also, connect a 0.1μF capacitor to GND near the pin to decrease common mode noise.

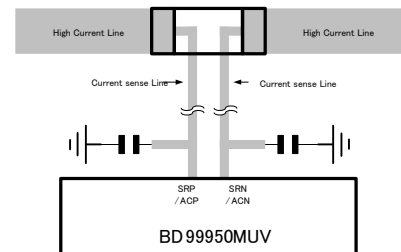

Figure 25. Current Sense Kelvin Layout

- LDRV
 The LDRV pin is the gate drive terminal of the low-side N-channel MOSFET. Extremely high charging/discharging slew rate in the gate of the MOSFET can cause a very large current to flow through the REGN, LDRV and GND terminals. It is therefore advisable to place the gate of the low-side N-channel MOSFET to the LDRV pin as close as possible. Enclosing the path with a ground shield is also recommended to lessen the unwanted effects of noise.

- HDRV and PHASE
 The HDRV pin is the gate drive terminal of the high-side N-channel MOSFET. Extremely high charging/discharging slew rate in the gate of the MOSFET can cause a very large current to flow through the BOOT, HDRV and PHASE terminals. It is therefore advisable to place the gate of the high-side N-channel MOSFET to the HDRV pin as close as possible. Enclosing the path with a ground shield is also recommended to lessen the unwanted effects of noise.

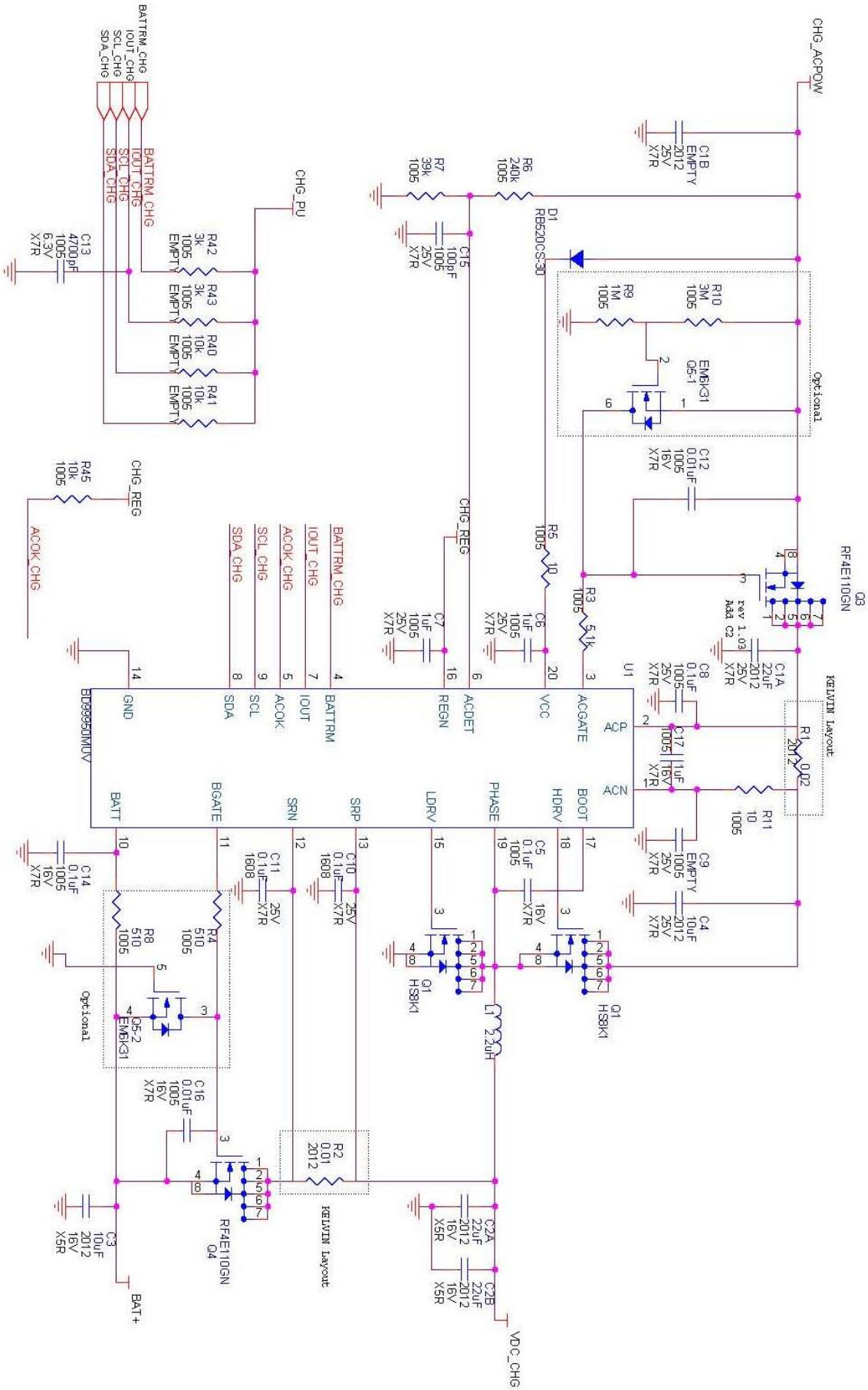

Figure 26. Reference Design Schematic

Application Example

Input Capacitor C1A (22 μ F)

Place input capacitor C1A, as close as possible to Q3 drain pin and ground.

Input Capacitor C4 (10 μ F)

Place input capacitor C4, as close as possible to Q1 drain pin and Q2 source pin.

Select C1A \geq C4 for Fast DPM operation.

Current Sense Resistor R1 (20m Ω), R2 (10m Ω)

Current sense Kelvin layout must be followed. (Refer to "Current Sense Resistance" on page 23.)

Current Sense Pin Capacitor C8, C10, C11 (0.1 μ F), C17(1 μ F), C9(Empty) and R11(10 Ω)

Place input capacitor C8, C9, C10, C11 as close as possible to their corresponding sense pins.

(Refer to "ACN and ACP Terminal Differential Mode Noise Filtering" on page 23.)

REGN Output Capacitor C7 (1 μ F)

Place output capacitor C7 as close as possible to REGN pin and to ground.

VCC Decoupling Capacitor C6 (1 μ F)

Place input decoupling capacitor C6 as close as possible to VCC pin and to ground.

Selection of Components Externally Connected

Reference Design	Value	Configuration			QTY	Rated Voltage	Manufacture	Part number
		X[mm]	Y[mm]	Z[mm]				
Q1, Q2	2in1	3.0	3.0	0.8	1	30V	Rohm	HS8K1
	-	2.0	2.0	0.8	2		Rohm	RF4E110GN
		3.3	3.3	0.8			Rohm	RQ3E120GN
Q3	-	2.0	2.0	0.8	1	30V	Rohm	RF4E110GN
		3.3	3.3	0.8			Rohm	RQ3E120GN
Q4	-	2.0	2.0	0.8	1	30V	Rohm	RF4E110GN
		3.3	3.3	0.8			Rohm	RQ3E120GN
Q5-1,Q5-2 (Optional)	2in1	1.6	1.6	0.5	1	30V	Rohm	EM6K31
L	2.2uH	6.5	7.4	3.0	1	-	ALPS	GLMC2R201A
		6.6	7.0	3.0			TOKO	FDSD0630-H-2R2M
		7.5	7.5	2.0			coilcraft	XAL7020-222ME
	1.5uH	4.0	4.0	1.8			coilcraft	KA5013-AE
C1A	22uF	2.0	1.25	1.25	1	25V	Murata	GRM21BR61E226ME44#
C1B(EMPTY)								
C2A,C2B	22uF	2.0	1.25	1.25	2	25V	Murata	GRM21BR61E226ME44#
C3	10uF	2.0	1.25	1.25	1	25V	Murata	GRM219BR61E106KA12#
C4	10uF	2.0	1.25	1.25	1	25V	Murata	GRM219BR61E106KA12#
C5	0.1uF	1.0	0.5	0.5	1	16V	Std.	Ceramic Capacitor X5R 10%
C6	1.0uF	1.0	0.5	0.5	1	25V	Murata	GRM155R61E105KA12
C7	1.0uF	1.0	0.5	0.5	1	16V	Std.	Ceramic Capacitor X5R 10%
C8	0.1uF	1.0	0.5	0.5	2	25V	Std.	Ceramic Capacitor X5R 10%
C9(Empty)								
C10,C11	0.1uF	1.0	0.5	0.5	2	25V	Std.	Ceramic Capacitor X5R 10%
C12	0.01uF	1.0	0.5	0.5	1	16V	Std.	Ceramic Capacitor X5R 10%
C13	4700pF	1.0	0.5	0.5	1	6.3V	Std.	Ceramic Capacitor X5R 10%
C14	0.1uF	1.0	0.5	0.5	1	16V	Std.	Ceramic Capacitor X5R 10%
C15(Optional)	100pF	1.0	0.5	0.5	1	16V	Std.	Ceramic Capacitor X5R 10%
C16	0.01uF	1.0	0.5	0.5	1	16V	Std.	Ceramic Capacitor X5R 10%
C17	1.0uF	1.0	0.5	0.5	1	16V	Std.	Ceramic Capacitor X5R 10%
D1	-	1.0	0.6	0.4	1	30V	Rohm	RB520CS-30
R1	20mΩ	2.0	1.2	0.3	1	-	Rohm	UCR10EVHFSR020
R2	10mΩ	2.0	1.2	0.3	1	-	Rohm	PMR10EZPFU10L0
R3(Optional)	5.1kΩ	1.0	0.5	0.35	1	-	Std.	1%
R4,R8 (Optional)	510Ω	1.0	0.5	0.35	2	-	Std.	1%
R5	10Ω	1.0	0.5	0.35	1	-	Std.	1%
R6	240kΩ	1.0	0.5	0.35	1	-	Std.	1%
R7	39kΩ	1.0	0.5	0.35	1	-	Std.	1%
R9(Optional)	1MΩ	1.0	0.5	0.35	1	-	Std.	1%
R10(Optional)	3MΩ	1.0	0.5	0.35	1	-	Std.	1%
R11	10Ω	1.0	0.5	0.35	1	-	Std.	1%
R40(Empty)								
R41(Empty)								
R42(Empty)								
R43(Empty)								
R45	10kΩ	1.0	0.5	0.35	1	-	Std.	1%

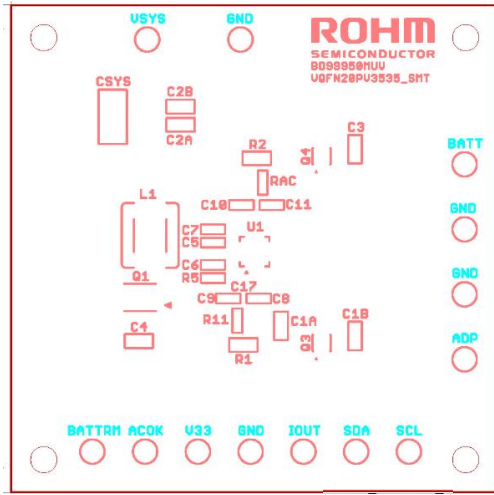

Figure 27. TOP Silk Screen

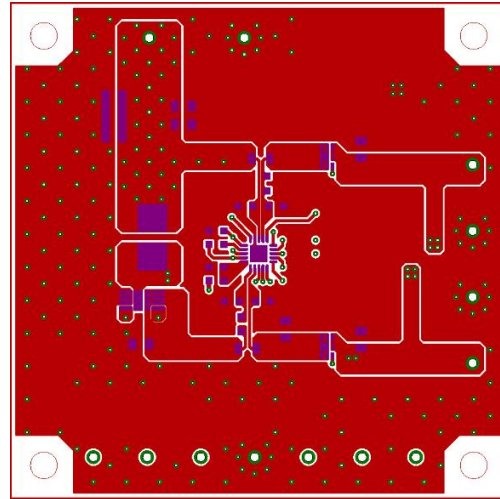

Figure 28. TOP Copper Trace Layer (Signal and Ground)

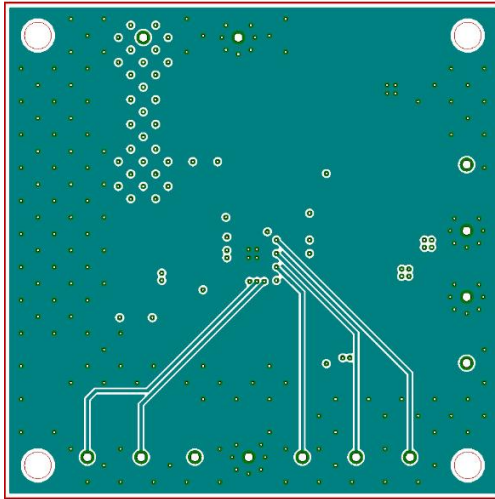

Figure 29. Middle 1 Copper Trace Layer (Ground)

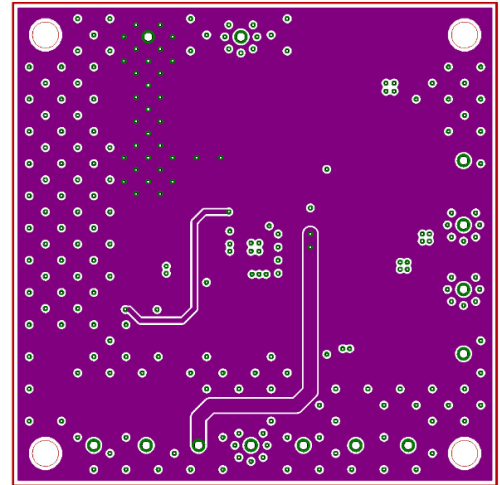

Figure 30. Middle 2 Copper Trace Layer (Signal and System Output)

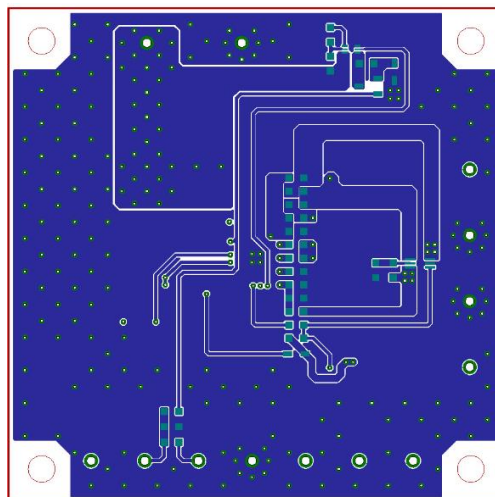

Figure 31. Bottom Copper Trace Layer (Signal and Ground)

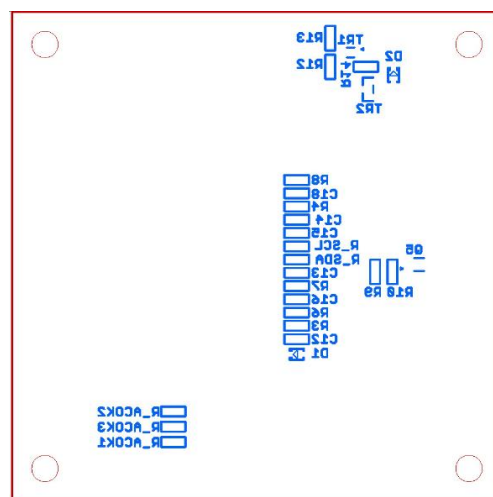

Figure 32. Bottom Silk Screen

Example of Recommended Circuit

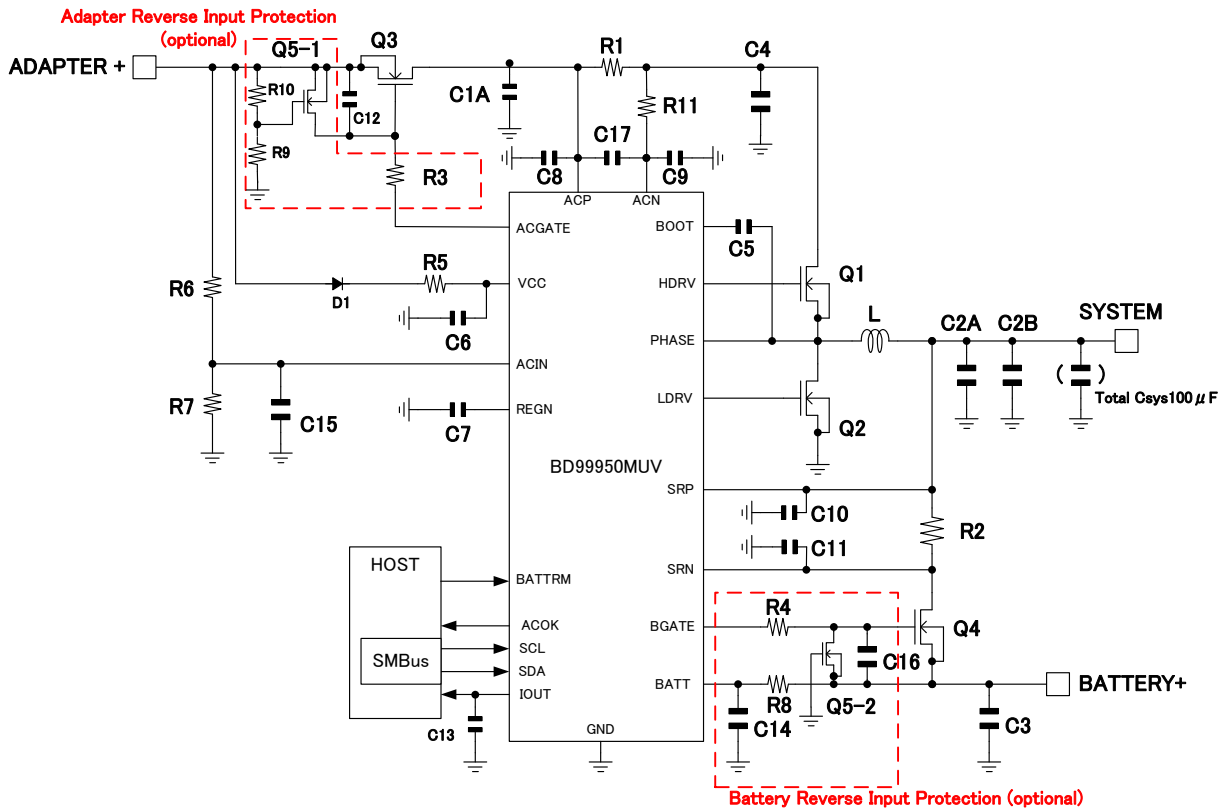

Figure 33. Example of Application Circuit (AC Adapter and Battery Reverse Input Protected Configuration)

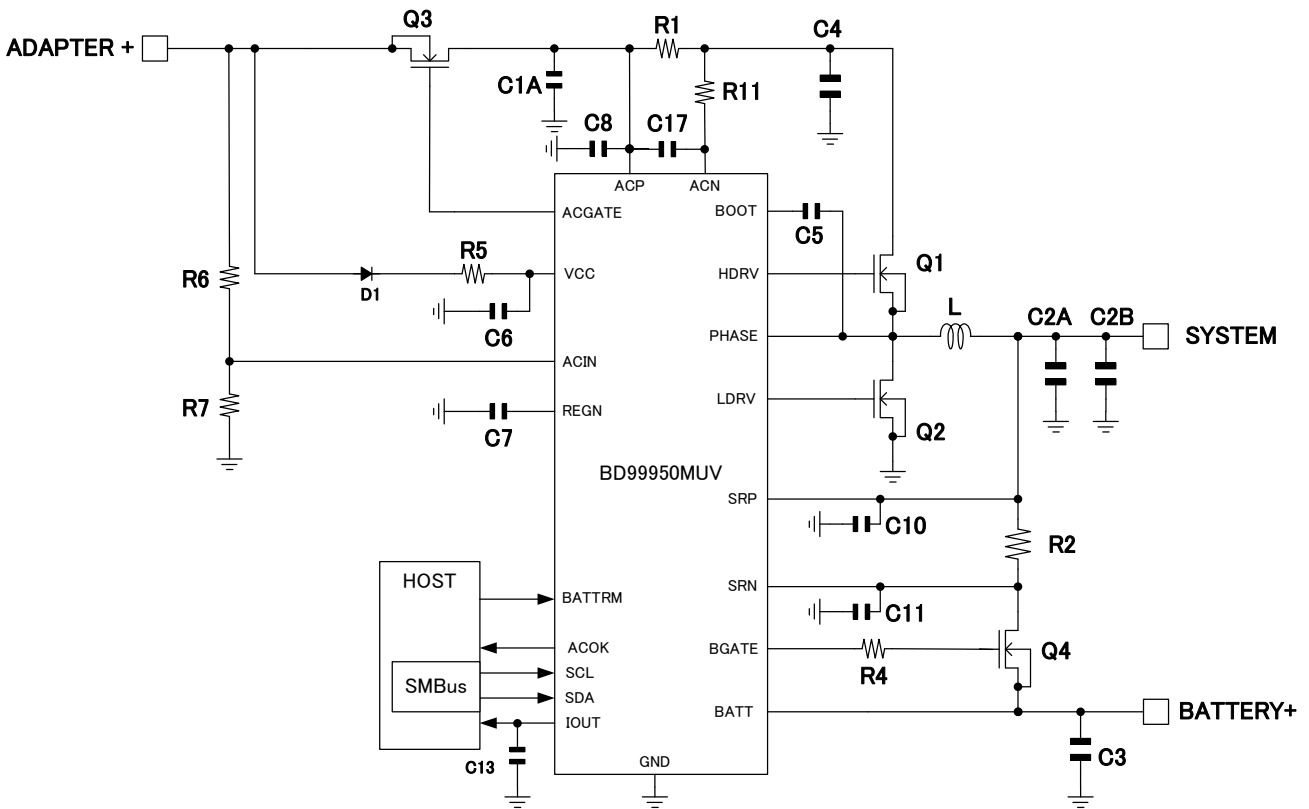

Figure 34. Example of Application Circuit (Minimum Component Configuration)

Power Dissipation

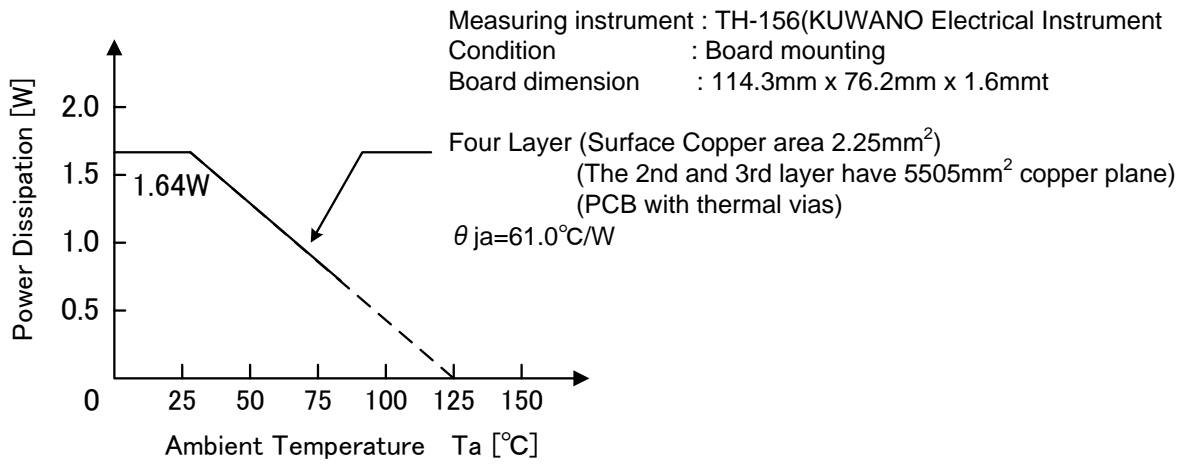

Figure 35. Power Dissipation (Solder operated on the PAD backside of 4 layer substrate)

Operational Notes

1. Reverse Connection of Power Supply

Connecting the power supply in reverse polarity can damage the IC. Take precautions against reverse polarity when connecting the power supply, such as mounting an external diode between the power supply and the IC's power supply pins.

2. Power Supply Lines

Design the PCB layout pattern to provide low impedance supply lines. Separate the ground and supply lines of the digital and analog blocks to prevent noise in the ground and supply lines of the digital block from affecting the analog block. Furthermore, connect a capacitor to ground at all power supply pins. Consider the effect of temperature and aging on the capacitance value when using electrolytic capacitors.

3. Ground Voltage

Ensure that no pins are at a voltage below that of the ground pin at any time, even during transient condition. However, pins that drive inductive loads (e.g. motor driver outputs, DC-DC converter outputs) may inevitably go below ground due to back EMF or electromotive force. In such cases, the user should make sure that such voltages going below ground will not cause the IC and the system to malfunction by examining carefully all relevant factors and conditions such as motor characteristics, supply voltage, operating frequency and PCB wiring to name a few.

4. Ground Wiring Pattern

When using both small-signal and large-current ground traces, the two ground traces should be routed separately but connected to a single ground at the reference point of the application board to avoid fluctuations in the small-signal ground caused by large currents. Also ensure that the ground traces of external components do not cause variations on the ground voltage. The ground lines must be as short and thick as possible to reduce line impedance.

5. Thermal Consideration

Should by any chance the power dissipation rating be exceeded the rise in temperature of the chip may result in deterioration of the properties of the chip. The absolute maximum rating of the Pd stated in this specification is when the IC is mounted on a 70mm x 70mm x 1.6mm glass epoxy board. In case of exceeding this absolute maximum rating, increase the board size and copper area to prevent exceeding the Pd rating.

6. Recommended Operating Conditions

These conditions represent a range within which the expected characteristics of the IC can be approximately obtained. The electrical characteristics are guaranteed under the conditions of each parameter.

7. Inrush Current

When power is first supplied to the IC, it is possible that the internal logic may be unstable and inrush current may flow instantaneously due to the internal powering sequence and delays, especially if the IC has more than one power supply. Therefore, give special consideration to power coupling capacitance, power wiring, width of ground wiring, and routing of connections.

8. Operation Under Strong Electromagnetic Field

Operating the IC in the presence of a strong electromagnetic field may cause the IC to malfunction.

9. Testing on Application Boards

When testing the IC on an application board, connecting a capacitor directly to a low-impedance output pin may subject the IC to stress. Always discharge capacitors completely after each process or step. The IC's power supply should always be turned off completely before connecting or removing it from the test setup during the inspection process. To prevent damage from static discharge, ground the IC during assembly and use similar precautions during transport and storage.

10. Inter-pin Short and Mounting Errors

Ensure that the direction and position are correct when mounting the IC on the PCB. Incorrect mounting may result in damaging the IC. Avoid nearby pins being shorted to each other especially to ground, power supply and output pin. Inter-pin shorts could be due to many reasons such as metal particles, water droplets (in very humid environment) and unintentional solder bridge deposited in between pins during assembly to name a few.

Operational Notes – continued

11. Unused Input Pins

Input pins of an IC are often connected to the gate of a MOS transistor. The gate has extremely high impedance and extremely low capacitance. If left unconnected, the electric field from the outside can easily charge it. The small charge acquired in this way is enough to produce a significant effect on the conduction through the transistor and cause unexpected operation of the IC. So unless otherwise specified, unused input pins should be connected to the power supply or ground line.

12. Regarding the Input Pin of the IC

This monolithic IC contains P+ isolation and P substrate layers between adjacent elements in order to keep them isolated. P-N junctions are formed at the intersection of the P layers with the N layers of other elements, creating a parasitic diode or transistor. For example (refer to figure below):

When $GND > Pin A$ and $GND > Pin B$, the P-N junction operates as a parasitic diode.
When $GND > Pin B$, the P-N junction operates as a parasitic transistor.

Parasitic diodes inevitably occur in the structure of the IC. The operation of parasitic diodes can result in mutual interference among circuits, operational faults, or physical damage. Therefore, conditions that cause these diodes to operate, such as applying a voltage lower than the GND voltage to an input pin (and thus to the P substrate) should be avoided.

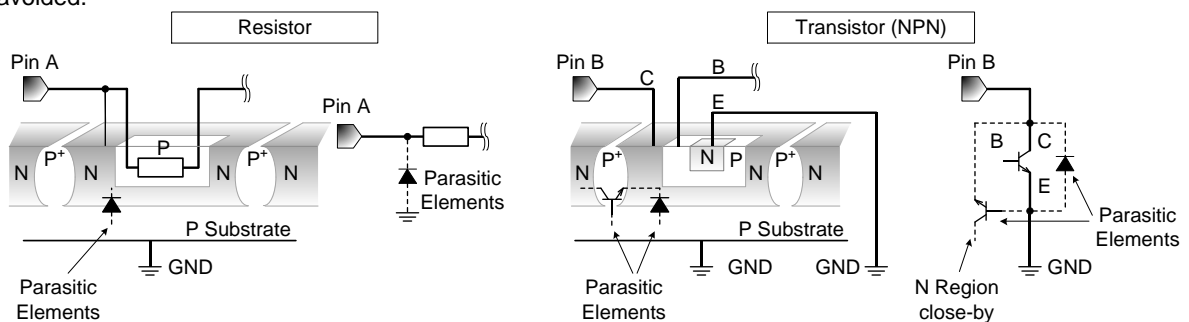

Figure 36. Example of monolithic IC structure

13. Ceramic Capacitor

When using a ceramic capacitor, determine the dielectric constant considering the change of capacitance with temperature and the decrease in nominal capacitance due to DC bias and others.

14. Area of Safe Operation (ASO)

Operate the IC such that the output voltage, output current, and power dissipation are all within the Area of Safe Operation (ASO).

15. Thermal Shutdown Circuit(TSD)

This IC has a built-in thermal shutdown circuit that prevents heat damage to the IC. Normal operation should always be within the IC's power dissipation rating. If however the rating is exceeded for a continued period, the junction temperature (T_j) will rise which will activate the TSD circuit that will turn OFF all output pins. When the T_j falls below the TSD threshold, the circuits are automatically restored to normal operation.

Note that the TSD circuit operates in a situation that exceeds the absolute maximum ratings and therefore, under no circumstances, should the TSD circuit be used in a set design or for any purpose other than protecting the IC from heat damage.

16. Over Current Protection Circuit (OCP)

This IC incorporates an integrated overcurrent protection circuit that is activated when the load is shorted. This protection circuit is effective in preventing damage due to sudden and unexpected incidents. However, the IC should not be used in applications characterized by continuous operation or transitioning of the protection circuit.

Ultrabook is trademarks of Intel Corporation in the U.S. and/or other countries.

Ordering Information

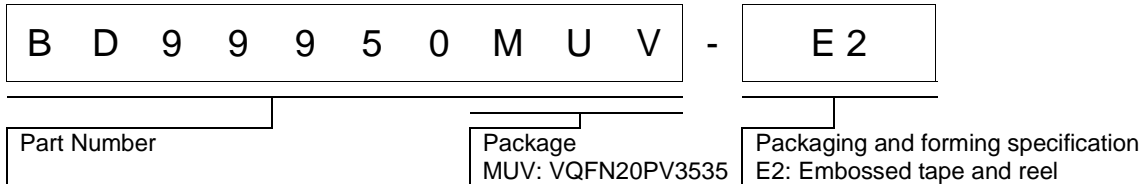

Marking Diagrams

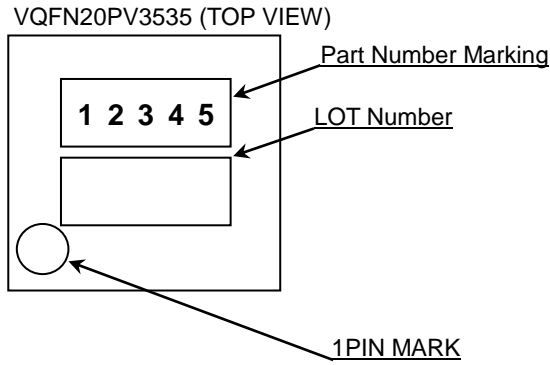

Part Number Marking	Package	Orderable Part Number
BD99950	VQFN20PV3535	BD99950MUV-E2

Physical Dimension, Tape and Reel Information

VQFN20PV3535

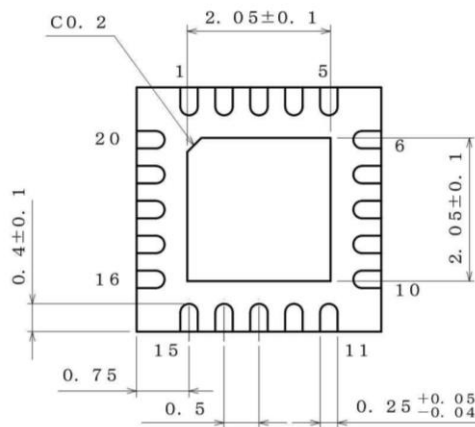
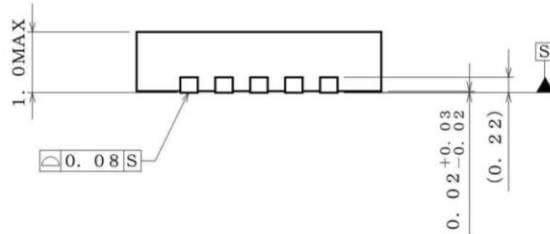
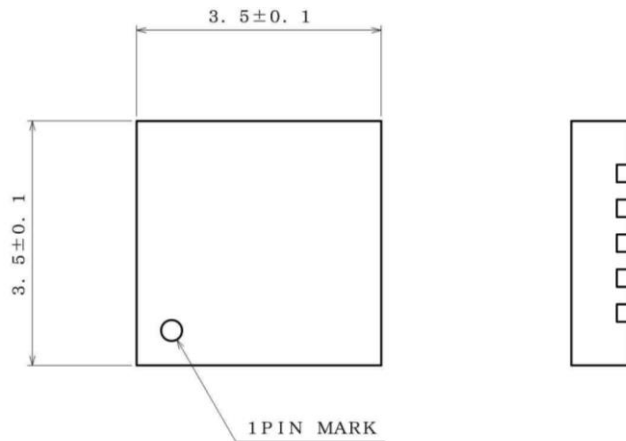

(UNIT : mm)
 PKG : VQFN20PV3535
 Drawing No. EX499-5001

< Tape and Reel Information >

Tape	Embossed carrier tape
Quantity	2500pcs
Direction of feed	E2 The direction is the pin 1 of product is at the upper left when you hold reel on the left hand and you pull out the tape on the right hand

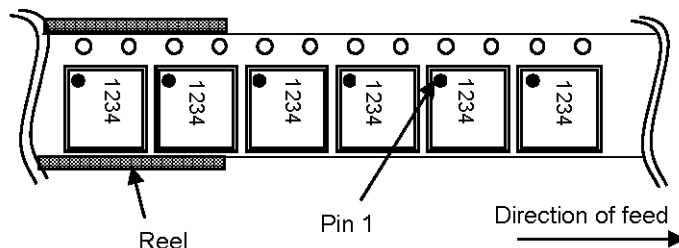

Revision History

Date	Revision	Changes
29.Aug.2013	001	New Release
06.Jan.2014	002	Page.1 Charge Current Accuracy -> Charge Voltage Accuracy. Page.2 Figure.1 Change Typical Application Circuit. Page.8 Figure.4 Time division 200ms->2ms change. Page.23 Add sentence about Current Sensing Resistor. Page.24 Figure.26 Change Example of Recommended Circuit.
29.Jun.2015	003	Page.1 Modify Switching Frequency Range from 800kHz to 1200kHz to 600kHz to 1200kHz.
08.Aug.2016	004	Page.2 Modified Figure 1 of Typical Application circuit. Page.3 Modified ACN pin's Descriptions. Page.3 Modified BATT pin's Descriptions. Page.3 Modified BGATE pin's Descriptions. Page.5 Modified Power Dissipation in Absolute Maximum Rating table. Page.8 Modified Layout Figure 3,4,5,6. Page.9 Modified Layout Figure 7,8,9,10. Page.10 Modified Layout Figure 11,12,13,14. Page.11 Modified Layout Figure 15,16,17,18. Page.12 Modified Layout of Figure 19,20,21. Page.22 Modified External Components Selection. Page.24 Modified Figure 26 of Application Example. Page.25 Rename of External capacitor C1 to C1A. Page.25 Modified C1A's Descriptions. Page.25 Modified Current sense Resistor and Capacitor of C8 , C10 , C11 , C9 , C17,and R11. Page.26 Modified List of Selection of Components Externally Connected, Page.27 Modified Figure of PCB Layout, Page.28 Modified Component name of Figure 33 and Figure 34. Page.33 Replacement High Resolution Graphic Data.

Notice

Precaution on using ROHM Products

- Our Products are designed and manufactured for application in ordinary electronic equipments (such as AV equipment, OA equipment, telecommunication equipment, home electronic appliances, amusement equipment, etc.). If you intend to use our Products in devices requiring extremely high reliability (such as medical equipment ^(Note 1), transport equipment, traffic equipment, aircraft/spacecraft, nuclear power controllers, fuel controllers, car equipment including car accessories, safety devices, etc.) and whose malfunction or failure may cause loss of human life, bodily injury or serious damage to property ("Specific Applications"), please consult with the ROHM sales representative in advance. Unless otherwise agreed in writing by ROHM in advance, ROHM shall not be in any way responsible or liable for any damages, expenses or losses incurred by you or third parties arising from the use of any ROHM's Products for Specific Applications.

(Note1) Medical Equipment Classification of the Specific Applications

JAPAN	USA	EU	CHINA
CLASS III	CLASS III	CLASS II b	CLASS III
CLASS IV		CLASS III	

- ROHM designs and manufactures its Products subject to strict quality control system. However, semiconductor products can fail or malfunction at a certain rate. Please be sure to implement, at your own responsibilities, adequate safety measures including but not limited to fail-safe design against the physical injury, damage to any property, which a failure or malfunction of our Products may cause. The following are examples of safety measures:
 - Installation of protection circuits or other protective devices to improve system safety
 - Installation of redundant circuits to reduce the impact of single or multiple circuit failure
- Our Products are designed and manufactured for use under standard conditions and not under any special or extraordinary environments or conditions, as exemplified below. Accordingly, ROHM shall not be in any way responsible or liable for any damages, expenses or losses arising from the use of any ROHM's Products under any special or extraordinary environments or conditions. If you intend to use our Products under any special or extraordinary environments or conditions (as exemplified below), your independent verification and confirmation of product performance, reliability, etc. prior to use, must be necessary:
 - Use of our Products in any types of liquid, including water, oils, chemicals, and organic solvents
 - Use of our Products outdoors or in places where the Products are exposed to direct sunlight or dust
 - Use of our Products in places where the Products are exposed to sea wind or corrosive gases, including Cl₂, H₂S, NH₃, SO₂, and NO₂
 - Use of our Products in places where the Products are exposed to static electricity or electromagnetic waves
 - Use of our Products in proximity to heat-producing components, plastic cords, or other flammable items
 - Sealing or coating our Products with resin or other coating materials
 - Use of our Products without cleaning residue of flux (even if you use no-clean type fluxes, cleaning residue of flux is recommended); or Washing our Products by using water or water-soluble cleaning agents for cleaning residue after soldering
 - Use of the Products in places subject to dew condensation
- The Products are not subject to radiation-proof design.
- Please verify and confirm characteristics of the final or mounted products in using the Products.
- In particular, if a transient load (a large amount of load applied in a short period of time, such as pulse. is applied, confirmation of performance characteristics after on-board mounting is strongly recommended. Avoid applying power exceeding normal rated power; exceeding the power rating under steady-state loading condition may negatively affect product performance and reliability.
- De-rate Power Dissipation depending on ambient temperature. When used in sealed area, confirm that it is the use in the range that does not exceed the maximum junction temperature.
- Confirm that operation temperature is within the specified range described in the product specification.
- ROHM shall not be in any way responsible or liable for failure induced under deviant condition from what is defined in this document.

Precaution for Mounting / Circuit board design

- When a highly active halogenous (chlorine, bromine, etc.) flux is used, the residue of flux may negatively affect product performance and reliability.
- In principle, the reflow soldering method must be used on a surface-mount products, the flow soldering method must be used on a through hole mount products. If the flow soldering method is preferred on a surface-mount products, please consult with the ROHM representative in advance.

For details, please refer to ROHM Mounting specification

Precautions Regarding Application Examples and External Circuits

1. If change is made to the constant of an external circuit, please allow a sufficient margin considering variations of the characteristics of the Products and external components, including transient characteristics, as well as static characteristics.
2. You agree that application notes, reference designs, and associated data and information contained in this document are presented only as guidance for Products use. Therefore, in case you use such information, you are solely responsible for it and you must exercise your own independent verification and judgment in the use of such information contained in this document. ROHM shall not be in any way responsible or liable for any damages, expenses or losses incurred by you or third parties arising from the use of such information.

Precaution for Electrostatic

This Product is electrostatic sensitive product, which may be damaged due to electrostatic discharge. Please take proper caution in your manufacturing process and storage so that voltage exceeding the Products maximum rating will not be applied to Products. Please take special care under dry condition (e.g. Grounding of human body / equipment / solder iron, isolation from charged objects, setting of Ionizer, friction prevention and temperature / humidity control).

Precaution for Storage / Transportation

1. Product performance and soldered connections may deteriorate if the Products are stored in the places where:
 - [a] the Products are exposed to sea winds or corrosive gases, including Cl₂, H₂S, NH₃, SO₂, and NO₂
 - [b] the temperature or humidity exceeds those recommended by ROHM
 - [c] the Products are exposed to direct sunshine or condensation
 - [d] the Products are exposed to high Electrostatic
2. Even under ROHM recommended storage condition, solderability of products out of recommended storage time period may be degraded. It is strongly recommended to confirm solderability before using Products of which storage time is exceeding the recommended storage time period.
3. Store / transport cartons in the correct direction, which is indicated on a carton with a symbol. Otherwise bent leads may occur due to excessive stress applied when dropping of a carton.
4. Use Products within the specified time after opening a humidity barrier bag. Baking is required before using Products of which storage time is exceeding the recommended storage time period.

Precaution for Product Label

A two-dimensional barcode printed on ROHM Products label is for ROHM's internal use only.

Precaution for Disposition

When disposing Products please dispose them properly using an authorized industry waste company.

Precaution for Foreign Exchange and Foreign Trade act

Since concerned goods might be fallen under listed items of export control prescribed by Foreign exchange and Foreign trade act, please consult with ROHM in case of export.

Precaution Regarding Intellectual Property Rights

1. All information and data including but not limited to application example contained in this document is for reference only. ROHM does not warrant that foregoing information or data will not infringe any intellectual property rights or any other rights of any third party regarding such information or data.
2. ROHM shall not have any obligations where the claims, actions or demands arising from the combination of the Products with other articles such as components, circuits, systems or external equipment (including software).
3. No license, expressly or implied, is granted hereby under any intellectual property rights or other rights of ROHM or any third parties with respect to the Products or the information contained in this document. Provided, however, that ROHM will not assert its intellectual property rights or other rights against you or your customers to the extent necessary to manufacture or sell products containing the Products, subject to the terms and conditions herein.

Other Precaution

1. This document may not be reprinted or reproduced, in whole or in part, without prior written consent of ROHM.
2. The Products may not be disassembled, converted, modified, reproduced or otherwise changed without prior written consent of ROHM.
3. In no event shall you use in any way whatsoever the Products and the related technical information contained in the Products or this document for any military purposes, including but not limited to, the development of mass-destruction weapons.
4. The proper names of companies or products described in this document are trademarks or registered trademarks of ROHM, its affiliated companies or third parties.

General Precaution

1. Before you use our Products, you are requested to carefully read this document and fully understand its contents. ROHM shall not be in any way responsible or liable for failure, malfunction or accident arising from the use of any ROHM's Products against warning, caution or note contained in this document.
2. All information contained in this document is current as of the issuing date and subject to change without any prior notice. Before purchasing or using ROHM's Products, please confirm the latest information with a ROHM sales representative.
3. The information contained in this document is provided on an "as is" basis and ROHM does not warrant that all information contained in this document is accurate and/or error-free. ROHM shall not be in any way responsible or liable for any damages, expenses or losses incurred by you or third parties resulting from inaccuracy or errors of or concerning such information.