

THIS COPY IS PROVIDED ON A RESTRICTED BASIS AND IS NOT TO BE USED IN ANY WAY DETRIMENTAL TO THE INTERESTS OF PANDUIT CORP.

PANDUIT P/N	WEIGHT
CFKE2A5U5J	1.03 LB/10 PCS (467.2 g/10 PCS)

- NOTES:
1. SEE CURRENT CATALOG FOR ADDITIONAL PART NUMBER SUFFIXES TO INDICATE COLOR AND OR PACKAGE QUANTITY.
 2. SEE CATALOG FOR COMPLETE LIST OF PARTS APPLICABLE FOR USE WITH THIS PART.
 3. DIMENSIONS IN [] ARE IN METRIC.
 4. PART INCLUDES:
 - 1- FACEPLATE (IW)
 - 2- LABEL
 - 2- LABEL COVER
 - 2- MOUNTING SCREW
 - 1- MINI-COM TX5e JACK MODULE (CJ5E88TGBU)
 - 1- MINI-COM TX5e JACK MODULE (CJ5E88TGOR)

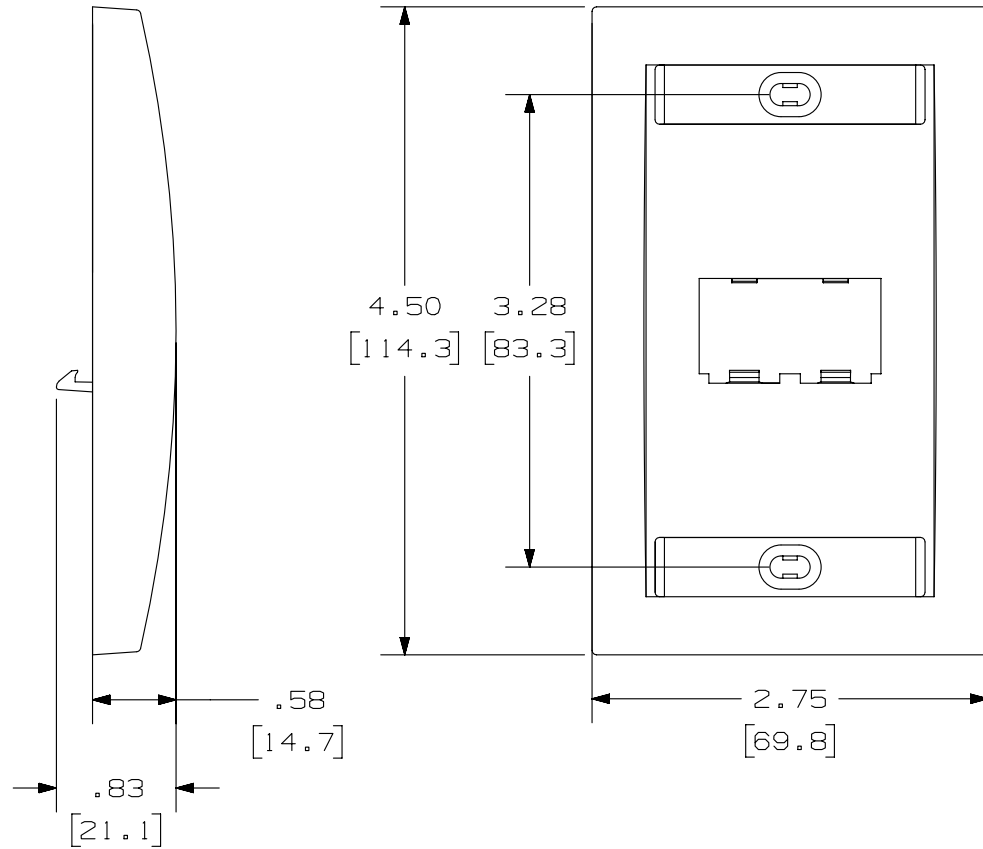

PART NUMBER		CFKE2A5U3A	
TITLE			
MINI-COM 2 POSITION EXECUTIVE		SERIES FACEPLATE KIT	
CUSTOMER DRAWING			
ITEM REVISION NAME		M00741NB/00	
DATASET FILE NAME		M00741NB_DC120/00C	
UNLESS OTHERWISE SPECIFIED, DIMENSIONAL TOLERANCES ARE: IN [mm]		MATERIAL:	
.x ± .xxx ± .010 [.3]		ABS	
.xx ± .03 [.8]		DRAWING NUMBER:	
ANGLES ±		00741-119	
THIRD ANGLE PROJECTION		SHT 1 OF 1	
DRAWN BY	DATE	CHK	SCALE
JSP	10-4-06	MJD	NONE
REV	DATE	BY	CHK
1	3/20/14	JSP	REFR
2	10-4-06	JSP	MJD
APR	DESCRIPTION		ECN
	A. REVISED DRAWING TITLE BLOCK.		00741-119
	RELEASED TO PRODUCTION		00741-119

D10100DA/14

Mouser Electronics

Authorized Distributor

Click to View Pricing, Inventory, Delivery & Lifecycle Information:

[Panduit:](#)

[CFKE2A5U5J](#)