

General Description

This N-Channel MOSFET has been designed specifically to improve the overall efficiency of DC/DC converters using either synchronous or conventional switching PWM controllers. It has been optimized for low gate charge, low $r_{DS(on)}$ and fast switching speed.

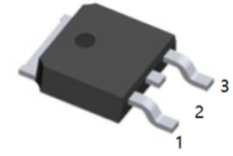

1.G 2.D 3.S
TO-252(DPAK) top view

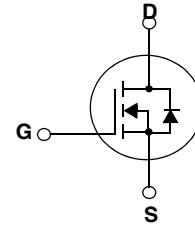

Features

- $V_{DS}(V) = 25V$
- $I_D = 35A$ ($V_{GS} = 10V$)
- $R_{DS(ON)} < 5.7m\Omega$ ($V_{GS} = 10V$)
- $R_{DS(ON)} < 8.0m\Omega$ ($V_{GS} = 4.5V$)
- Low gate charge: $Q_{g(10)} = 37nC(Typ)$, $V_{GS} = 10V$
- Low gate resistance

Application

- Vcore DC-DC for Desktop Computers and Servers
- VRM for Intermediate Bus Architecture

MOSFET Maximum Ratings $T_C = 25^\circ C$ unless otherwise noted

| Symbol | Parameter | Ratings | Units |
|----------------|---|------------|------------|
| V_{DS} | Drain to Source Voltage | 25 | V |
| V_{GS} | Gate to Source Voltage | ± 20 | V |
| I_D | Drain Current -Continuous (Package Limited) | 35 | A |
| | -Continuous (Die Limited) | 98 | |
| | -Pulsed (Note 1) | 305 | |
| E_{AS} | Single Pulse Avalanche Energy (Note 2) | 91 | mJ |
| P_D | Power Dissipation | 88 | W |
| T_J, T_{STG} | Operating and Storage Temperature | -55 to 175 | $^\circ C$ |

Thermal Characteristics

| | | | |
|-----------------|--|-----|--------------|
| $R_{\theta JC}$ | Thermal Resistance, Junction to Case TO_252, TO_251 | 1.7 | $^\circ C/W$ |
| $R_{\theta JA}$ | Thermal Resistance, Junction to Ambient TO_252, TO_251 | 100 | $^\circ C/W$ |
| $R_{\theta JA}$ | Thermal Resistance, Junction to Ambient TO-252, 1in ² copper pad area | 52 | $^\circ C/W$ |

Electrical Characteristics $T_J = 25^\circ\text{C}$ unless otherwise noted

| Symbol | Parameter | Test Conditions | Min | Typ | Max | Units |
|--|--|--|------------------------------|------|-----------|----------------------------|
| B_{VDSS} | Drain to Source Breakdown Voltage | $I_D = 250\mu\text{A}, V_{GS} = 0\text{V}$ | 25 | | | V |
| $\frac{\Delta B_{VDSS}}{\Delta T_J}$ | Breakdown Voltage Temperature Coefficient | $I_D = 250\mu\text{A}$, referenced to 25°C | | 7 | | $\text{mV}/^\circ\text{C}$ |
| I_{DSS} | Zero Gate Voltage Drain Current | $V_{DS} = 20\text{V}$ $V_{GS} = 0\text{V}$ $T_J = 150^\circ\text{C}$ | | | 1 250 | μA |
| I_{GSS} | Gate to Source Leakage Current | $V_{GS} = \pm 20\text{V}$ | | | ± 100 | nA |
| $V_{GS(th)}$ | Gate to Source Threshold Voltage | $V_{GS} = V_{DS}, I_D = 250\mu\text{A}$ | 1.2 | 1.8 | 2.5 | V |
| $\frac{\Delta V_{GS(th)}}{\Delta T_J}$ | Gate to Source Threshold Voltage Temperature Coefficient | $I_D = 250\mu\text{A}$, referenced to 25°C | | -6.7 | | $\text{mV}/^\circ\text{C}$ |
| $r_{DS(on)}$ | Drain to Source On Resistance | $V_{GS} = 10\text{V}, I_D = 35\text{A}$ | | 4.5 | 5.7 | m Ω |
| | | $V_{GS} = 4.5\text{V}, I_D = 35\text{A}$ | | 6.0 | 8.0 | |
| C_{iss} | Input Capacitance | $V_{DS} = 13\text{V}, V_{GS} = 0\text{V},$ $f = 1\text{MHz}$ | | 1960 | 2610 | pF |
| C_{oss} | Output Capacitance | | | 455 | 605 | pF |
| C_{rss} | Reverse Transfer Capacitance | | | 315 | 475 | pF |
| R_G | Gate Resistance | | $f = 1\text{MHz}$ | | 1.1 | |
| $t_{d(on)}$ | Turn-On Delay Time | $V_{DD} = 13\text{V}, I_D = 35\text{A}$ $V_{GS} = 10\text{V}, R_{GS} = 20\Omega$ | | 10 | 20 | ns |
| t_r | Rise Time | | | 24 | 39 | ns |
| $t_{d(off)}$ | Turn-Off Delay Time | | | 99 | 158 | ns |
| t_f | Fall Time | | | 57 | 91 | ns |
| Q_g | Total Gate Charge | | $V_{GS} = 0$ to 10V | | 37 | 52 |
| Q_g | Total Gate Charge | $V_{GS} = 0$ to 5V | | 19 | 27 | nC |
| Q_{gs} | Gate to Source Gate Charge | $V_{DD} = 13\text{V},$ $I_D = 35\text{A},$ $I_g = 1.0\text{mA}$ | | 6 | | nC |
| Q_{gd} | Gate to Drain Charge | | | 6 | | nC |
| V_{SD} | Source to Drain Diode Voltage | $V_{GS} = 0\text{V}, I_S = 35\text{A}$ | | 0.9 | 1.25 | V |
| | | $V_{GS} = 0\text{V}, I_S = 15\text{A}$ | | 0.8 | 1.0 | V |
| t_{rr} | Reverse Recovery Time | $I_F = 35\text{A}, di/dt = 100\text{A}/\mu\text{s}$ | | 30 | 45 | ns |
| Q_{rr} | Reverse Recovery Charge | $I_F = 35\text{A}, di/dt = 100\text{A}/\mu\text{s}$ | | 23 | 35 | nC |

Notes:

- 1: Pulse time < 300 μs , Duty cycle = 2%.
- 2: Starting $T_J = 25^\circ\text{C}$, $L = 0.3\text{mH}$, $I_{AS} = 24.7\text{A}$, $V_{DD} = 23\text{V}$, $V_{GS} = 10\text{V}$.

Typical Characteristics $T_J = 25^\circ\text{C}$ unless otherwise noted

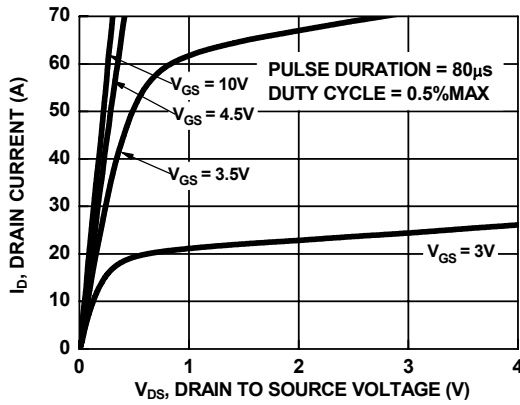

Figure 1. On Region Characteristics

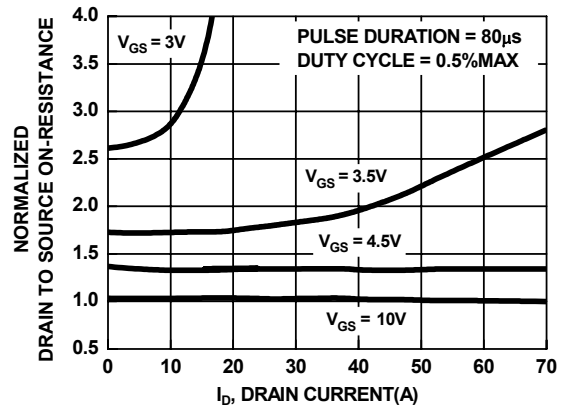

Figure 2. Normalized On-Resistance vs Drain Current and Gate Voltage

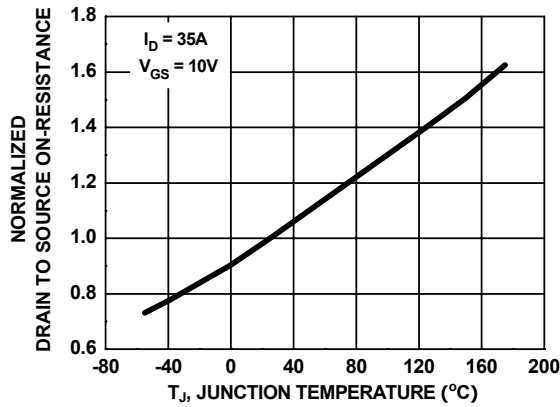

Figure 3. Normalized On Resistance vs Junction Temperature

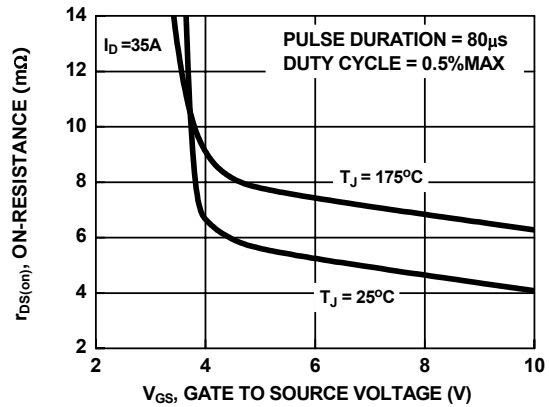

Figure 4. On-Resistance vs Gate to Source Voltage

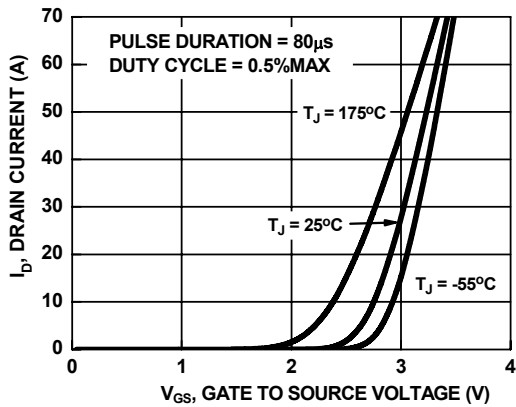

Figure 5. Transfer Characteristics

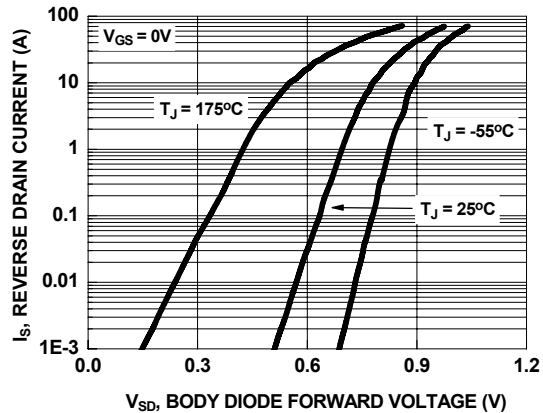

Figure 6. Source to Drain Diode Forward Voltage vs Source Current

Typical Characteristics $T_J = 25^\circ\text{C}$ unless otherwise noted

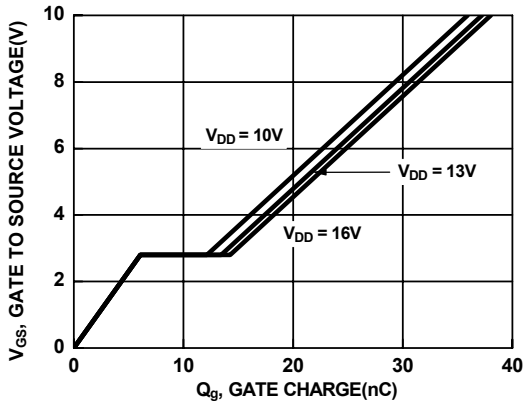

Figure 7. Gate Charge Characteristics

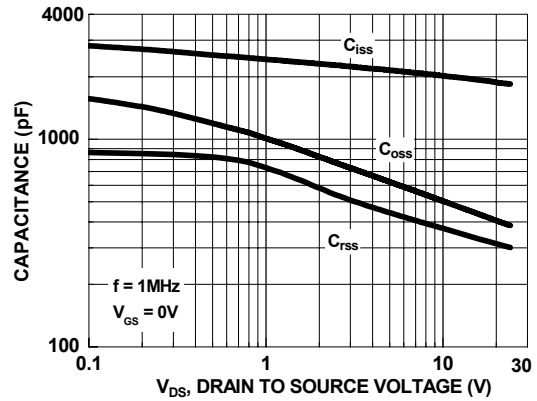

Figure 8. Capacitance vs Drain to Source Voltage

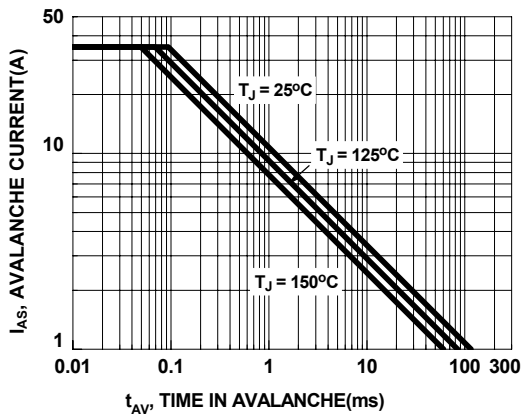

Figure 9. Unclamped Inductive Switching Capability

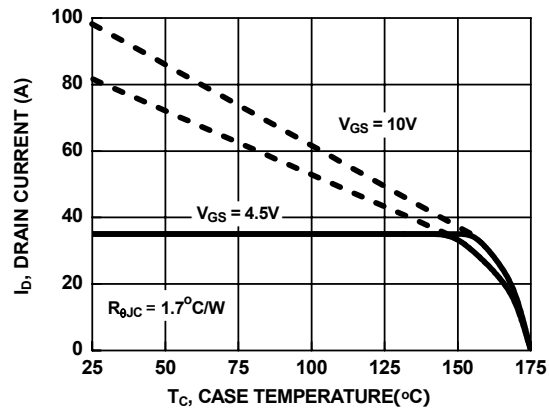

Figure 10. Maximum Continuous Drain Current vs Case Temperature

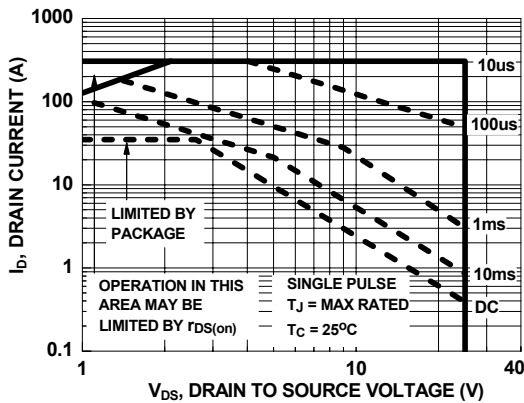

Figure 11. Forward Bias Safe Operating Area

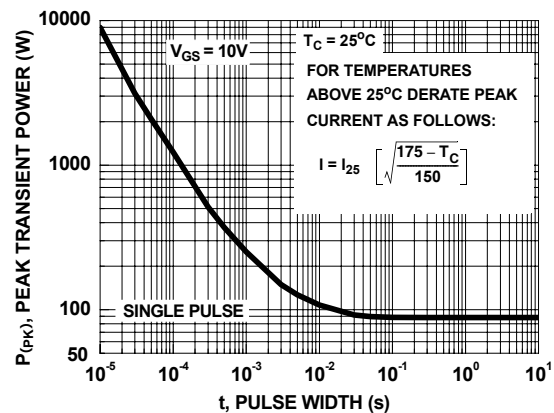

Figure 12. Single Pulse Maximum Power Dissipation

Typical Characteristics $T_J = 25^\circ\text{C}$ unless otherwise noted

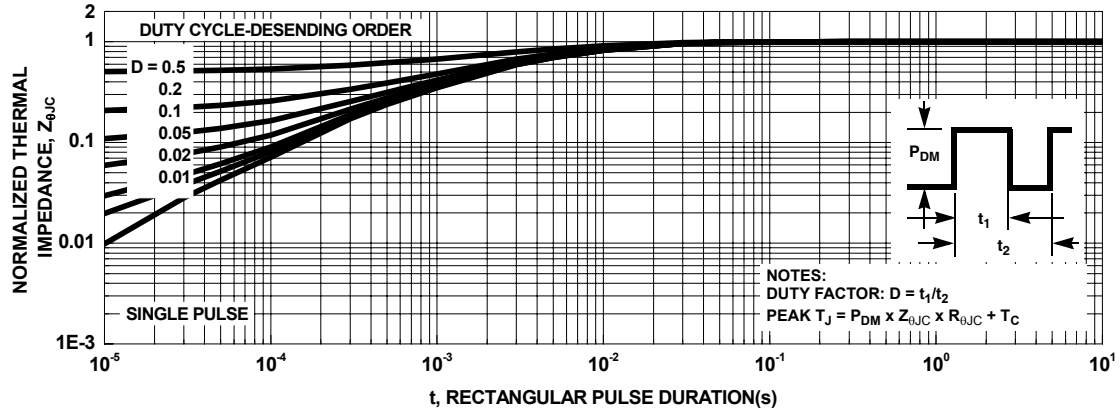
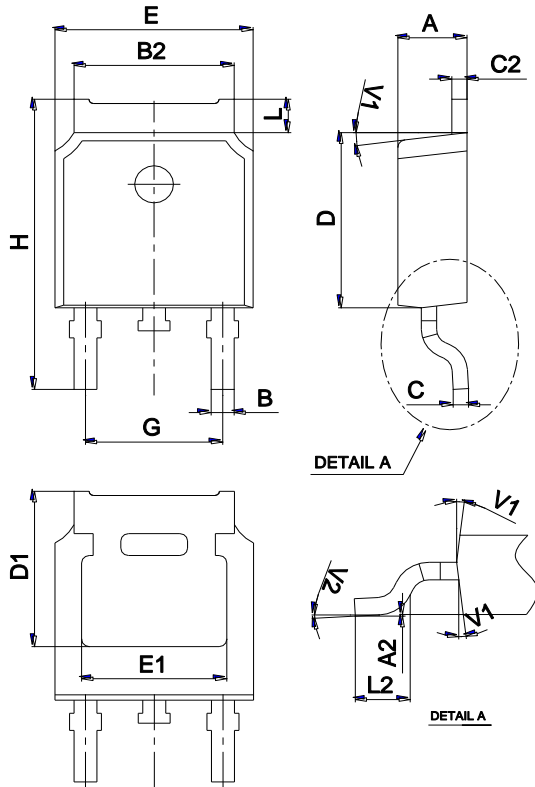

Figure 13. Transient Thermal Response Curve

Package Mechanical Data TO-252



| Ref. | Dimensions | | | | | |
|------|-------------|------|-------|----------|------|-------|
| | Millimeters | | | Inches | | |
| | Min. | Typ. | Max. | Min. | Typ. | Max. |
| A | 2.10 | | 2.50 | 0.083 | | 0.098 |
| A2 | 0 | | 0.10 | 0 | | 0.004 |
| B | 0.66 | | 0.86 | 0.026 | | 0.034 |
| B2 | 5.18 | | 5.48 | 0.202 | | 0.216 |
| C | 0.40 | | 0.60 | 0.016 | | 0.024 |
| C2 | 0.44 | | 0.58 | 0.017 | | 0.023 |
| D | 5.90 | | 6.30 | 0.232 | | 0.248 |
| D1 | 5.30REF | | | 0.209REF | | |
| E | 6.40 | | 6.80 | 0.252 | | 0.268 |
| E1 | 4.63 | | | 0.182 | | |
| G | 4.47 | | 4.67 | 0.176 | | 0.184 |
| H | 9.50 | | 10.70 | 0.374 | | 0.421 |
| L | 1.09 | | 1.21 | 0.043 | | 0.048 |
| L2 | 1.35 | | 1.65 | 0.053 | | 0.065 |
| V1 | | 7° | | | 7° | |
| V2 | 0° | | 6° | 0° | | 6° |

Marking

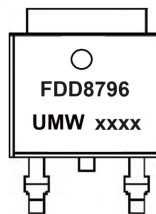

Ordering information

| Order code | Package | Baseqty | Deliverymode |
|-------------|---------|---------|---------------|
| UMW FDD8796 | TO-252 | 2500 | Tape and reel |