

Captive Screw Type 6 10-32 Thread

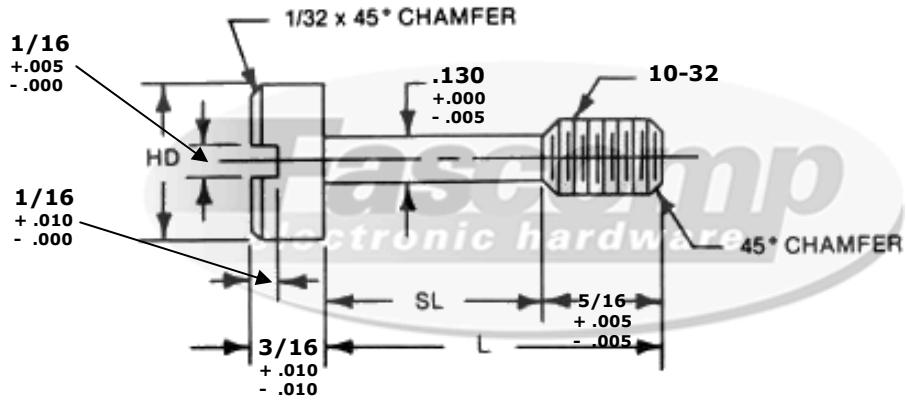

Create a part number:

Length	Material	Finish
FCXXXX	XX	XX

Captive Screws - 10-32 Thread				
✓	FCXXXX	Length (L)	H.D. +.005 -.005	S.L. +.005 -.000
	FC7091	27/32	3/8	17/32
	FC7092	29/32	3/8	19/32

Material	
✓ Material Code (XX)	
B	Brass
S	Steel
SS	Stainless Steel

✓ Compatible Finish (XX)	
B, S, SS	0 - Plain
B, S	5 - Nickel Plate (QQ-N-290)
B, S	12 - Zinc Clear (ASTM-B-633)
B, S	16 - Electro Tin (MIL-T-10727 TYPE 1)
SS	20 - Passivation (MIL-F-14072D)
B, S, SS	26 - Black Oxide
B, S	28 - Zinc Yellow (ASTM-B-633)

Tolerances
Unless otherwise Specified
 .xxx +/- .005
 .xx +/- .010
 Angular +/- 1 Degree
 Linear +/- .005
Break all sharp edges

Source Control Drawing:
 To be produced by
 Fascomp Electronic Hardware



Fascomp Electronic Hardware
 7814 Kingspointe Pkwy
 Orlando, FL 32819
 www.fascomp.com
 Tel: (407) 226-2112
 Fax: (407) 226-3370

This document is the property of Fascomp Inc. and shall not be reproduced, distributed, or used as a basis for manufacturing without written permission from Fascomp Inc.

Mouser Electronics

Authorized Distributor

Click to View Pricing, Inventory, Delivery & Lifecycle Information:

[Fascomp:](#)

[CFC7091-SS](#) [CFC7092-SS](#)