

# LV CONNECTOR

Disconnectable Crimp style connectors for 2.36 diameter pins

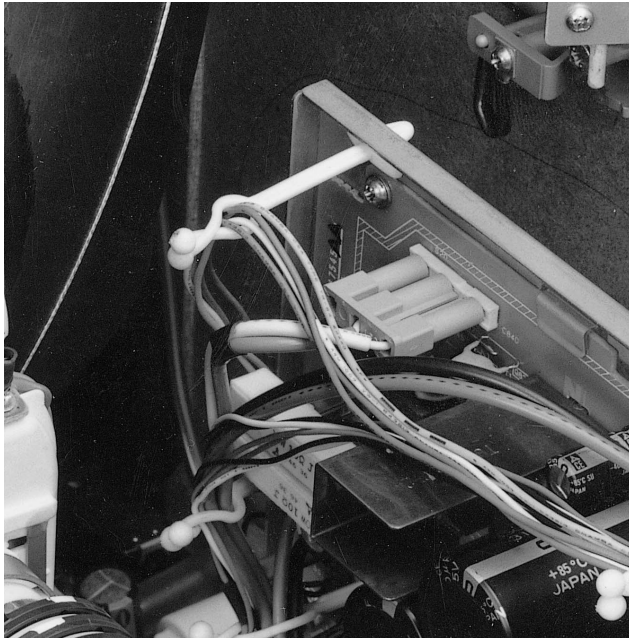

**This connector can be connected to headers having 2.36mm diameter pins. Since the pitch between circuits is large, 8.0mm, this connector is ideally suited for the power supply circuits of TVs, stereo systems and VCRs.**

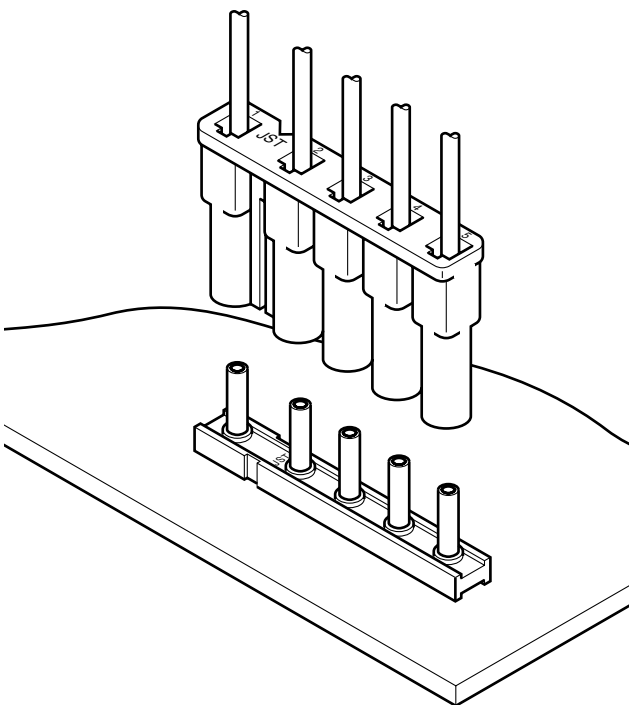

## Features

### • Three-point contact

The mating section of the contact has a triangular configuration so that the terminal grips the round mating pin at three points. Furthermore, this contact keeps its high force after mating and unmating many times, thus assuring high reliability.

### • Anti-misinsertion construction

The pitch between positions 1 and 2 of the housings and the headers having three or more circuits is 10.0mm, while the pitch of the other circuits is 8.0mm. This provides polarization which in turn prevents mismatching the connector.

### • Flux entry prevention

The solder side of the header pins are closed so as to completely prevent flux or solder from entering. The tight press-fit of the pin into the header insulator also prevents flux from coming up the pin.

## Specifications

- Current rating: SVF-01T-2.36N: 5A AC, DC (AWG #20)  
SVF-01T-2.36LN: 7A AC, DC (AWG #18)
- Voltage rating: 250V AC, DC
- Temperature range: -25°C to +85°C  
(including temperature rise in applying electrical current)
- Contact resistance: Initial value/10m Ω max.  
After environmental testing/20m Ω max.
- Insulation resistance: 1,000M Ω min.
- Withstanding voltage: 1,500V AC/minute
- Applicable wire: SVF-01T-2.36N: AWG #24 to #20  
SVF-01T-2.36LN: AWG #24 to #18
- Applicable PC board thickness: 1.6mm
- \* Compliant with RoHS.
- \* Refer to "General Instruction and Notice when using Terminals and Connectors" at the end of this catalog.
- \* Contact JST for details.

## Standards

Recognized E60389

Certified LR20812

R75121

# LV CONNECTOR

## Contact

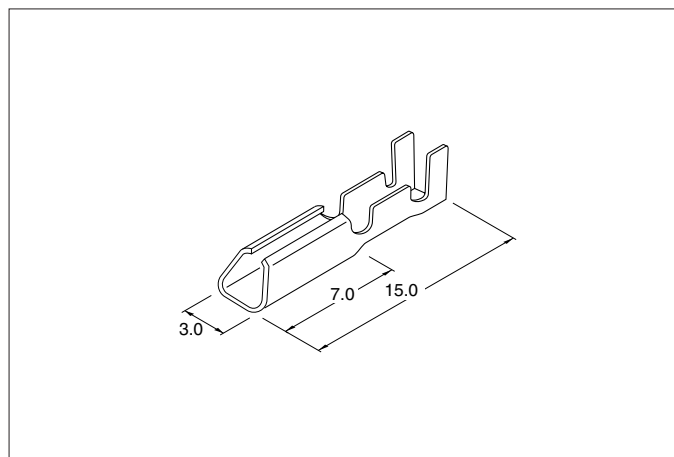

Model No.	Applicable wire			Qty / reel
	mm <sup>2</sup>	AWG #	Insulation O.D. (mm)	
<b>SVF-01T-2.36N</b>	0.2 to 0.5	24 to 20	1.4 to 2.7	15,000
<b>SVF-01T-2.36LN</b>	0.2 to 0.83	24 to 18	1.4 to 2.9	5,000

### Material and Finish

Phosphor bronze, tin-plated (reflow treatment)

### RoHS compliance

## Housing

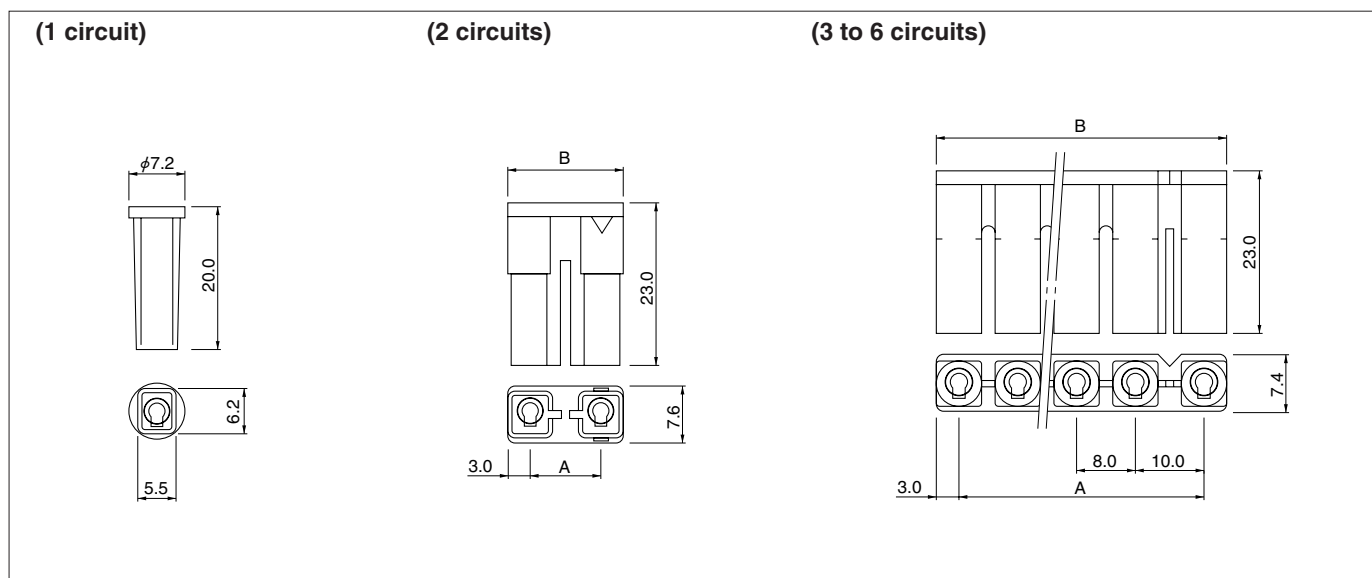

Cir- cuits	Model No.		Dimensions (mm)		Qty / bag
	Noryl	PBT	A	B	
1	<b>S1P-LV</b>	<b>S1P-LV-P</b>	—	—	1,000
2	<b>2P-LV</b>	<b>2P-LV-P</b>	10.0	16.0	1,000
3	<b>3P-LV</b>	<b>3P-LV-P</b>	18.0	24.0	500
4	<b>4P-LV</b>	<b>4P-LV-P</b>	26.0	32.0	500
5	<b>5P-LV</b>	<b>5P-LV-P</b>	34.0	40.0	500
6	<b>6P-LV</b>	<b>6P-LV-P</b>	42.0	48.0	500

### Material

S1P-LV, ( )P-LV: Modified PPE, UL94V-1, gray  
 S1P-LV-P, ( )P-LV-P: PBT, UL94V-0, black

### RoHS compliance

#### Precautions:

When using the housing made of Modified PPE, it has poor chemical resistance against oils and organic solvents. Do not allow the housing to come into contact with oil. Do not clean any printed circuit board while the housing is attached.

## Header

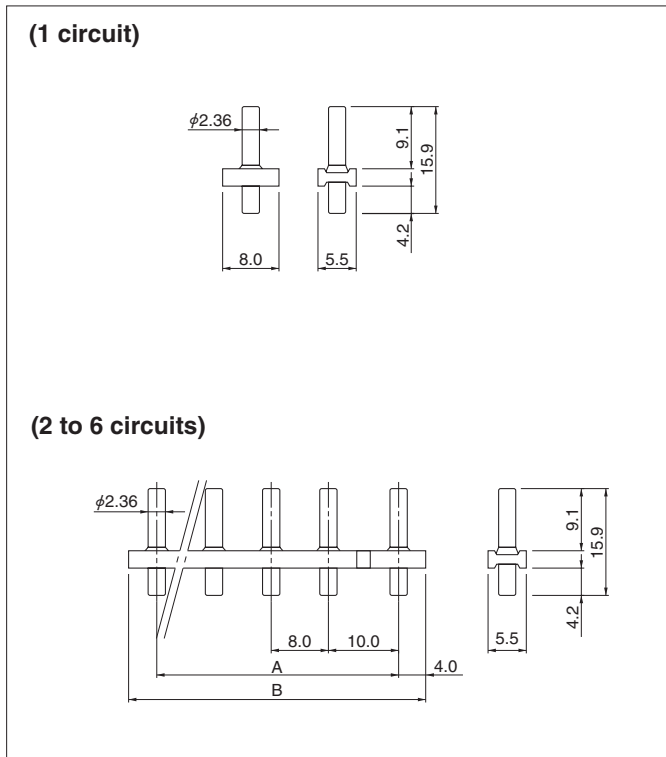

Applicable contact	Circuits	Model No.	Dimensions (mm)		Finish	Q'ty / box
			A	B		
SVF-01T-2.36N	1	B1P-LV-TA	—	—	Nickel-undercoated, tin/copper alloy-plated	1,000
		B1P-LV-TN	—	—		
	2	B2P-LV-TA	10.0	18.0	Nickel-undercoated, tin/copper alloy-plated	500
		B2P-LV-TN	10.0	18.0		
	3	B3P-LV-TN	18.0	26.0	Copper-undercoated, nickel-plated	500
	4	B4P-LV-TN	26.0	34.0		250
5	B5P-LV-TN	34.0	42.0	200		
6	B6P-LV-TN	42.0	50.0	—		
SVF-01T-2.36LN	1	B1P-LV-TA	—	—	Nickel-undercoated, tin/copper alloy-plated	1,000
		B2P-LV-TA	10.0	18.0		
	3	B3P-LV-TA	18.0	26.0	Nickel-undercoated, tin/copper alloy-plated	500
	4	B4P-LV-TA	26.0	34.0		250
	5	B5P-LV-TA	34.0	42.0		200
	6	B6P-LV-TA	42.0	50.0		—

### Material

Pin: Brass

Wafer: Glass filled PA 66, UL94V-0, natural (ivory)

**RoHS compliance** TA type products display (LF) on a label.

<For reference> As the color identification,

the following alphabet shall be put in the underlined part.

For availability, delivery and minimum order quantity, contact JST.

ex. **B2P-LV-TA-oo**

(blank)...natural (ivory)

BK...black

## PC board layout (viewed from soldering side) and Assembly layout

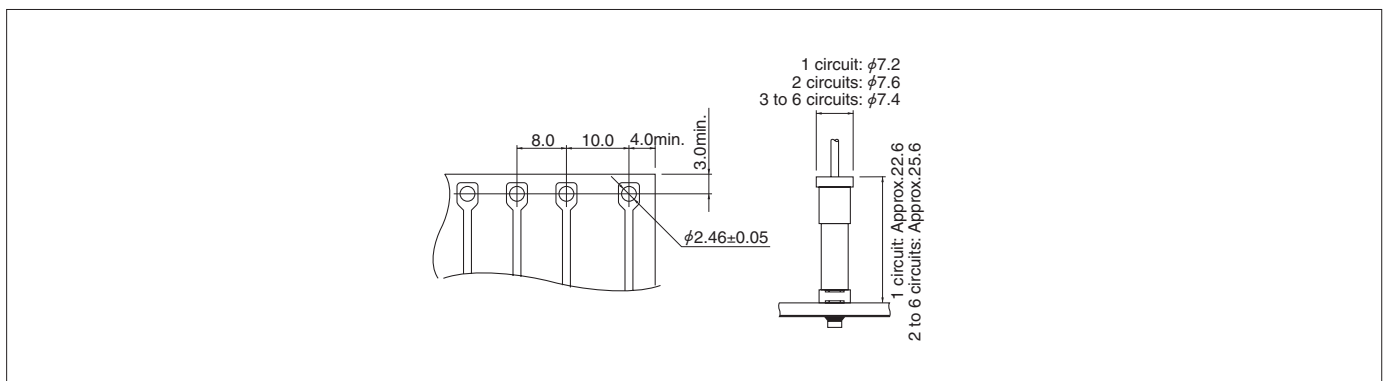

Note:

1. Tolerances are non-cumulative:  $\pm 0.05$ mm for all centers.

2. Hole dimensions differ according to the kind of PC board and piercing method. The dimensions above should serve as a guideline. Contact JST for details.

## Crimping machine, Applicator

Contact	Crimping machine	Crimp applicator	Dies	Crimp applicator with dies
SVF-01T-2.36N	AP-K2N	MK-L	MK/SVF-01-236N	APLMK SVF01-236N
		—	—	—

Contact	Crimping machine	Crimp applicator	Dies	Crimp applicator with dies
SVF-01T-2.36LN	AP-K2N	MKS-L	MK/SVF-01-236LN	APLMK SVF01-236LN
		—	—	—