

Low-Voltage 2-channel Electronic Volume with ealaBASS

■GENERAL DESCRIPTION

The **NJW1200** is a low-voltage 2-channel Electronic Volume with ealaBASS. It includes main volume, 2 stereo inputs selector (Differential Input), 2nd Order HPF. And It performs NJRC original dynamic bass boost technology “ealaBASS” provides graceful bass sound with low distortion.

The **NJW1200** performs low noise and low distortion characteristics with resistance ladder type electrical volume.

The **NJW1200** operates on low supply voltage. And It includes power save function. Therefore, it is suitable for low voltage supply portable systems.

All of internal status and variables are controlled by I²C BUS interface.

■PACKAGE OUTLINE



NJW1200V

■FEATURES

- Operating Voltage 2.7 to 5.5V
- Low Consumption 3mA typ.
- Power Save Function 120μA typ.
- I²C BUS Interface
- ealaBASS (Dynamic Bass Boost)
- eala (Surround Sound for stereo source) & eala MONO (Surround Sound for monaural source)
- Low Output Noise -100dBV typ.
- Low Distortion 0.07% typ.
- Main Volume 0 to -78dB / 2dB step, Mute
- 2 stereo Inputs Selector (Differential Input)
- 2nd Order HPF
- Bi-CMOS Technology
- Package Outline SSOP32

■BLOCK DIAGRAM

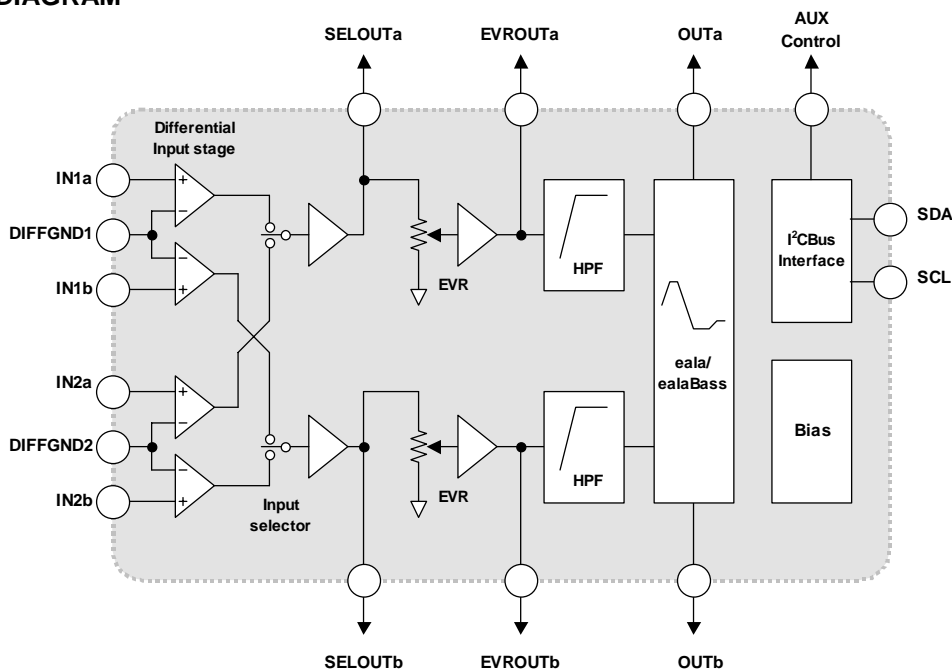

■PIN FUNCTION

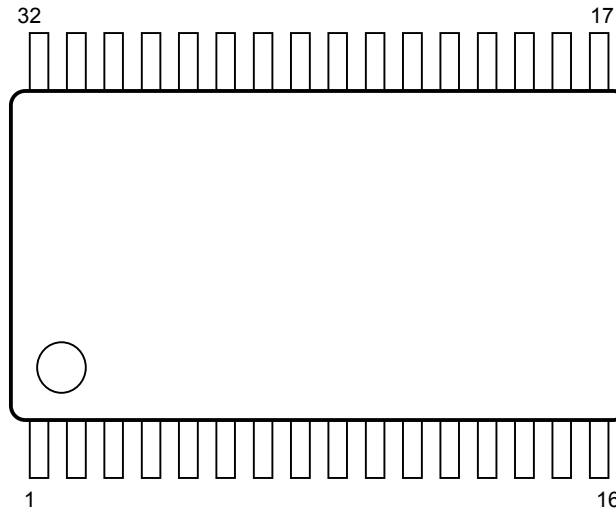

No.	SYMBOL	FUNCTION	No.	SYMBOL	FUNCTION
1	IN2a	Ach Input 2	17	V ⁺	Power Supply
2	DIFFGND2	Ground Input 2 for Differential	18	VREF	Reference Voltage
3	IN2b	Bch Input 2	19	SURTC	eala Switching-noise Rejection Capacitor
4	SELOUTa	Ach Selector Output	20	ealaFilter	ealaFilter
5	EVRINa	Ach Electronic Volume Input	21	OUTb	Bch Output
6	EVROUTa	Ach Electronic Volume Output	22	ealaBASS LPF2	ealaBASS Low Pass Filter 2
7	HPF1a	Ach High Pass Filter 1	23	ealaBASS LPF3	ealaBASS Low Pass Filter 3
8	HPF2a	Ach High Pass Filter 2	24	HBSTb	Bch High Boost Filter
9	HBSTa	Ach High Boost Filter	25	HPF2b	Bch High Pass Filter 2
10	ealaBASS LPF1	ealaBASS Low Pass Filter 1	26	HPF1b	Bch High Pass Filter 1
11	ealaBASS INT	ealaBASS Smoothing Filter Capacitor	27	EVROUTb	Bch Electronic Volume Output
12	OUTa	Ach Output	28	EVRINb	Bch Electronic Volume Input
13	AUX	Auxiliary Output	29	SELOUTb	Bch Selector Output
14	SDA	I ² C Data Input	30	IN1b	Bch Input 1
15	SCL	I ² C Clock Input	31	DIFFGND1	Ground Input 1 for Differential
16	GND	Ground	32	IN1a	Ach Input 1

■ ABSOLUTE MAXIMUM RATING (Ta=25°C)

PARAMETER	SYMBOL	RATING	UNIT
Supply Voltage	V ⁺	7	V
Power Dissipation	P _D	800 NOTE: EIA/JEDEC STANDARD Test board (76.2x114.3x1.6mm, 2layer, FR-4) mounting	mW
Maximum Input Voltage	V _{IM}	0 to V ⁺	V
Operating Temperature Range	Topr	-40 to +85	°C
Storage Temperature Range	Tstg	-40 to +125	°C

■ ELECTRICAL CHARACTERISTICS (Ta=25°C, V⁺=3.3V, eala=OFF, ealaBass=OFF)

■ DC Characteristics

PARAMETER	SYMBOL	TEST CONDITION	MIN.	TYP.	MAX.	UNIT
Operating Voltage	V ⁺		2.7	3.3	5.5	V
Supply Current 1	I _{DD1}	No Signal, AUX=High, Active mode	-	3	8	mA
Supply Current 2	I _{DD2}	No Signal, AUX=High, Power save mode	-	120	180	μA
Reference DC Voltage	V _{REF}	No Signal, Vref	-	V ⁺ /2	-	V
Output DC Voltage	V _{OUT}	No Signal, OUTa/b	1.5	1.65	1.8	V
AUX Output Voltage High	V _{AUXH}	Logic Output : High	V _{pullup} -0.5	-	V _{pullup}	V
AUX Output Voltage Low	V _{AUXL}	Logic Output : Low	0	-	0.5	V

* V_{pullup} : the external pull-up voltage (1.5V to V⁺)

■ AC Characteristics (Rg=0Ω, R_L=10kΩ, Vin=1kHz/100mVrms, Volume=0dB, OUTa/b)

PARAMETER	SYMBOL	TEST CONDITION	MIN.	TYP.	MAX.	UNIT
Maximum Voltage Gain	G _{VMAX}		-1.0	0.0	1.0	dB
Minimum Voltage Gain	G _{VMIN}	Volume=Mute, Vin=-3dBV, BW=400Hz to 30kHz	-80	-	-	dB
Channel Balance	G _{CB}		-1.0	0.0	1.0	dB
Channel Separation	CS	Vin=-3dBV	-50	-60	-	dB
Maximum Output Voltage	V _{OM}	THD=10%	-	-3.0	-	dBV
Total Harmonic Distortion	THD	BW=400Hz to 30kHz	-	0.07	0.3	%
Output Noise 1	V _{NO1}	A-Weighted	-	-100	-	dBV
Output Noise 2	V _{NO2}	Volume = Mute, A-Weighted	-	-105	-	dBV
Output Noise 3	V _{NO3}	A-Weighted, eala mode="eala Low", eBSW="ealaBASS ON", ealaBASS effect="BB Low"	-	-95	-	dBV
PSRR	PSRR	V _{RIPPLE} =50mVrms	-40	-50	-	dB

■ Isolation Amp. /Selector Characteristics (Rg=0Ω, R_L=10kΩ, f=1kHz, SELOUTa/b)

PARAMETER	SYMBOL	TEST CONDITION	MIN.	TYP.	MAX.	UNIT
Voltage Gain	G _v	Vin=100mVrms	-0.5	0.0	0.5	dB
Cross Talk	CT	Vin=-3dBV, INa+Inb→SELOUTa/b	-70	-	-	dB
CMRR	CMRR	Vin=-3dBV, INa+DIFFGND+Inb→ SELOUTa/b	-35	-	-	dB

■HPF Characteristics (R_g=0Ω, R_L=10kΩ, Vin=100mVrms, Volume=0dB, OUTa/b)

PARAMETER	SYMBOL	TEST CONDITION	MIN.	TYP.	MAX.	UNIT
HPF Voltage Gain	G _{VHPF}	f=50Hz	-7.5	-4.5	-1.5	dB

■eala Characteristics (R_g=0Ω, R_L=10kΩ, Vin=1kHz/100mVrms, Volume=0dB, OUTa/b)

PARAMETER	SYMBOL	TEST CONDITION	MIN.	TYP.	MAX.	UNIT
Simulated Stereo A	G _{SIMA}	INa+INb→OUTa, f=1kHz eala mode= "eala MONO"	0.5	3.0	5.5	dB
Simulated Stereo B	G _{SIMB}	INa+INb→OUTb, f=1kHz eala mode= "eala MONO"	0.5	3.0	5.5	dB
Surround 3D1	G _{3D1}	INa→OUTa, f=200Hz eala mode= "eala Low"	3.0	5.5	8.0	dB
Surround 3D2	G _{3D2}	INa→OUTa, f=200Hz eala mode= "eala High"	7.0	9.5	12.0	dB
Surround 3D3	G _{3D3}	INa→OUTb, f=200Hz eala mode= "eala High"	3.5	6.0	8.5	dB

■ealaBass Characteristics (R_g=0Ω, R_L=10kΩ, Vin=1kHz/100mVrms, Volume=0dB, OUTa/b)

PARAMETER	SYMBOL	TEST CONDITION	MIN.	TYP.	MAX.	UNIT
ealaBass1	G _{eB1}	INa+INb→OUTa/b, f=100Hz, eBSW="ealaBASS ON", ealaBASS effect= "BB High"	-	12.0	-	dB
ealaBass2	G _{eB2}	INa+INb→OUTa/b, f=100Hz, eBSW="ealaBASS ON", ealaBASS effect= "BB Middle"	-	9.5	-	dB
ealaBass3	G _{eB3}	INa+INb→OUTa/b, f=100Hz, eBSW="ealaBASS ON", ealaBASS effect= "BB Low"	-	7.0	-	dB
High Boost	G _{HB}	INa+INb→OUTa/b, f=10kHz, eBSW="ealaBASS ON", ealaBASS effect= "BB High"	-	3.0	-	dB

■ TERMINAL DESCRIPTION

PIN NO.	SYMBOL	FUNCTION	EQUIVALENT CIRCUIT	TERMINAL DC VOLTAGE
1 3 30 32	IN2a IN2b IN1b IN1a	Ach Input 2 Bch Input 2 Bch Input 1 Bch Input 1		$V^+/2$ [V]
2 31	DIFFGND2 DIFFGND1	Ground Input 2 for Differential Ground Input 1 for Differential		$V^+/2$ [V]
4 29 6 27 12 21	SELOUTa SELOUTb EVROUTa EVROUTb OUTa OUTb	Ach Selector Output Bch Selector Output Ach Electronic Volume Output Bch Electronic Volume Output Ach Output Bch Output		$V^+/2$ [V]
5 28	EVRINa EVRINb	Ach Electronic Volume Input Bch Electronic Volume Input		$V^+/2$ [V]

■ TERMINAL DESCRIPTION

PIN NO.	SYMBOL	FUNCTION	EQUIVALENT CIRCUIT	TERMINAL DC VOLTAGE
7 26	HPF1a HPF1b	Ach High Pass Filter 1 Bch High Pass Filter 1		$V^{+}/2$ [V]
8 25	HPF2a HPF2b	Ach High Pass Filter 2 Bch High Pass Filter 2		$V^{+}/2$ [V]
9 24	HBSTa HBSTb	Ach High Boost Filter Bch High Boost Filter		$V^{+}/2$ [V]
10	ealaBASS LPF1	ealaBASS Low Pass Filter 1		$V^{+}/2$ [V]

■ TERMINAL DESCRIPTION

PIN NO.	SYMBOL	FUNCTION	EQUIVALENT CIRCUIT	TERMINAL DC VOLTAGE
22	ealaBASS LPF2	ealaBASS Low Pass Filter 2		$V^+/2$ [V]
23	ealaBASS LPF3	ealaBASS Low Pass Filter 3		$V^+/2$ [V]
11	ealaBASS INT	ealaBASS Smoothing Filter Capacitor		0.7 [V]
20	ealaFilter	eala Filter		$V^+/2$ [V]

■ TERMINAL DESCRIPTION

PIN NO.	SYMBOL	FUNCTION	EQUIVALENT CIRCUIT	TERMINAL DC VOLTAGE
19	SURTC	External Switching-noise Rejection Capacitor		-
18	VREF	Reference Voltage		$V^+/2$ [V]
13	AUX	Auxiliary Output		High : V_{pullup} [V] Low : 0V
14 15	SDA SCL	I ² C Data Input I ² C Clock Input		-

■TIMING ON THE I²C BUS (SDA,SCL)

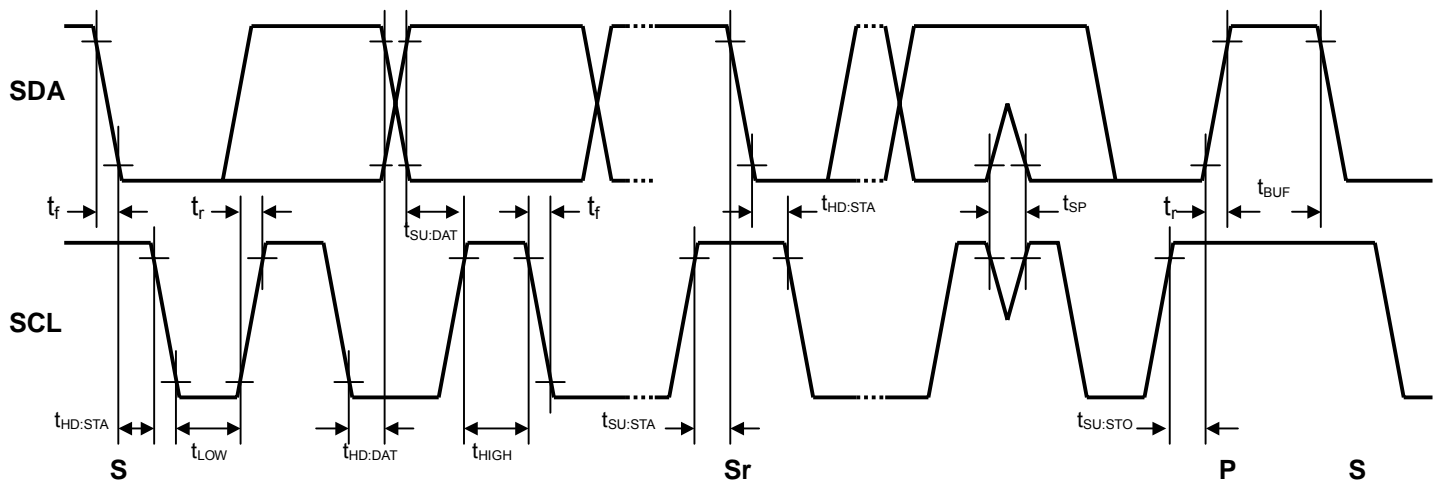

■CHARACTERISTICS OF I/O STAGES FOR I²C BUS (SDA,SCL)

I²C BUS Load Conditions

STANDARD MODE : Pull up resistance 4k Ω (Connected to +5V), Load capacitance 200pF (Connected to GND)

FAST MODE : Pull up resistance 4k Ω (Connected to +5V), Load capacitance 50pF (Connected to GND)

PARAMETER	SYMBOL	Standard mode			Fast mode			UNIT
		MIN.	TYP.	MAX.	MIN.	TYP.	MAX.	
Low Level Input Voltage	V _{IL}	0	-	V ⁺ *0.3	0	-	V ⁺ *0.3	V
High Level Input Voltage	V _{IH}	V ⁺ *0.7	-	V ⁺	V ⁺ *0.7	-	V ⁺	V
Low level output voltage (3mA at SDA pin)	V _{OL}	0	-	0.4	0	-	0.4	V
Input current each I/O pin with an input voltage between 0.1V _{DD} and 0.9V _{DDmax}	I _i	-10	-	10	-10	-	10	μ A

■CHARACTERISTICS OF BUS LINES (SDA,SCL) FOR I²C-BUS DEVICES

PARAMETER	SYMBOL	Standard mode			Fast mode			UNIT
		MIN.	TYP.	MAX.	MIN.	TYP.	MAX.	
SCL clock frequency	f _{SCL}	-	-	100	-	-	400	kHz
Hold time (repeated) START condition.	t _{HD:STA}	4.0	-	-	0.6	-	-	μs
Low period of the SCL clock	t _{LOW}	4.7	-	-	1.3	-	-	μs
High period of the SCL clock	t _{HIGH}	4.0	-	-	0.6	-	-	μs
Set-up time for a repeated START condition	t _{SU:STA}	4.7	-	-	0.6	-	-	μs
Data hold time ^(NOTE)	t _{HD:DAT}	0	-	-	0	-	-	μs
Data set-up time	t _{SU:DAT}	250	-	-	100	-	-	ns
Rise time of both SDA and SCL signals	t _r	-	-	1000	-	-	300	ns
Fall time of both SDA and SCL signals	t _f	-	-	300	-	-	300	ns
Set-up time for STOP condition	t _{SU:STO}	4.0	-	-	0.6	-	-	μs
Bus free time between a STOP and START condition	t _{BUF}	4.7	-	-	1.3	-	-	μs
Capacitive load for each bus line	C _b	-	-	400	-	-	400	pF
Noise margin at the Low level	V _{nL}	0.5	-	-	0.5	-	-	V
Noise margin at the High level	V _{nH}	1	-	-	1	-	-	V

C_b ; total capacitance of one bus line in pF.

NOTE). Data hold time : t_{HD:DAT}

Please hold the Data Hold Time (t_{HD:DAT}) to 300ns or more to avoid status of unstable at SCL falling edge.

The SDA block in the NJW1200 does not hold data. Add external data-delay-circuit of the SDA terminal, in case of not providing a hold time of at least 300nsec for the SDA in the master device.

The time-consists of the data-delay-circuit of the SDA terminal are as follows.

- (a) Low level → High level : $T_{LH} \approx R_P \cdot C_D$
- (b) High level → Low level : $T_{HL} \approx R_D \cdot C_D$

In addition, Schottky barrier diode (SBD) influences a Low level at the Acknowledge. Therefore choose the low forward voltage (V_f) as much as possible.

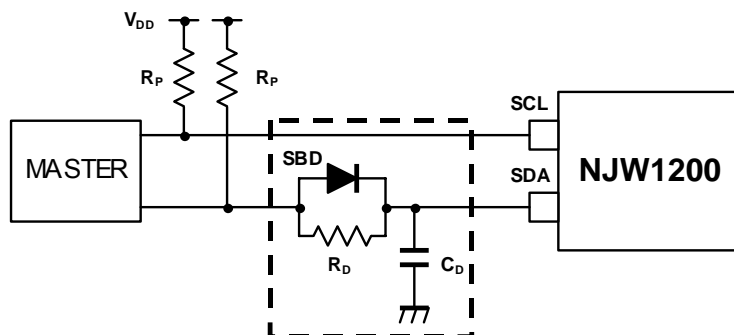

Application Circuit 1 (Measurement Circuit)

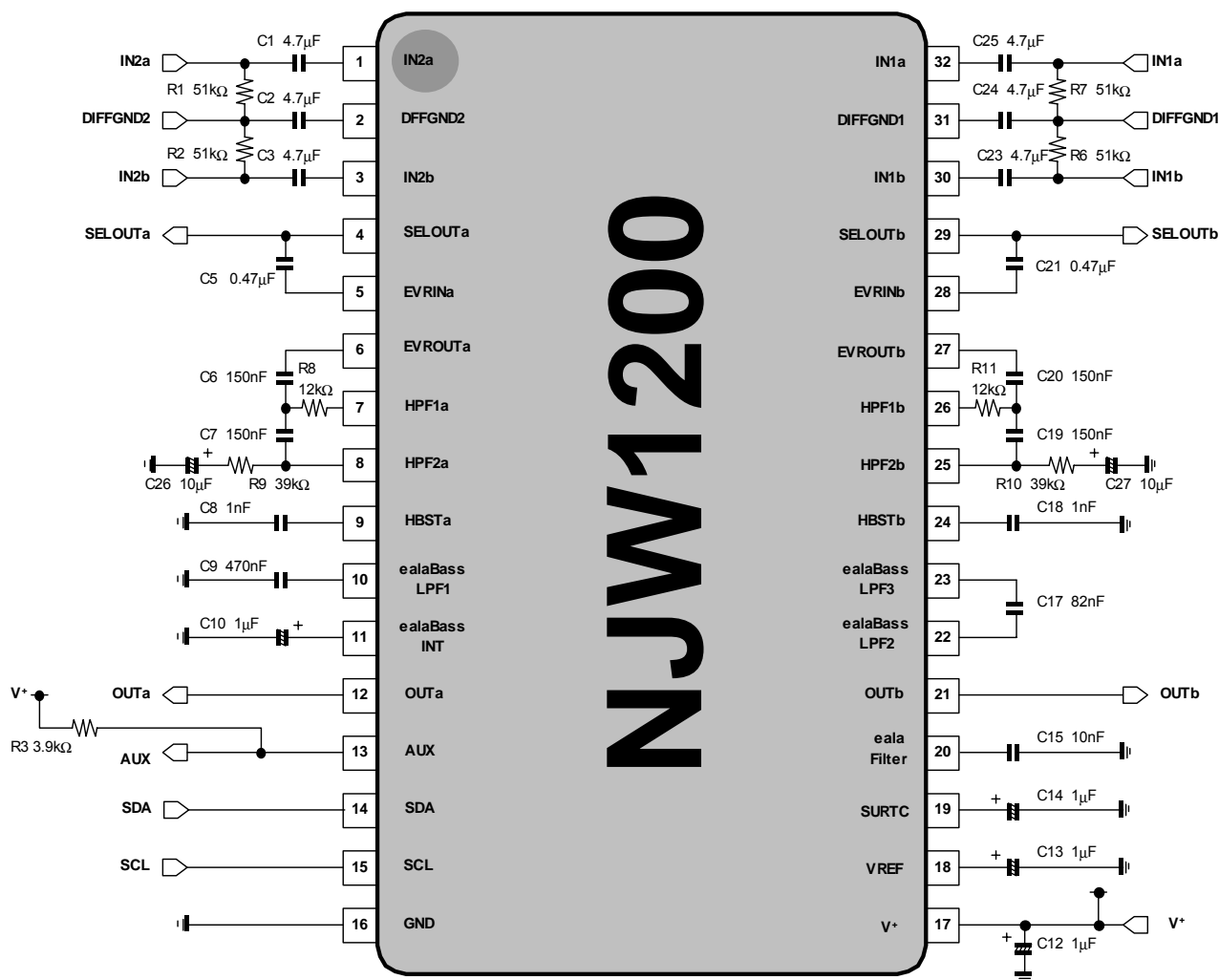

(*) Separate the I²C bus line and Signal line from the following terminals for avoiding digital noise problem and cross talk.

Pin No.	Function
1 - 3, 5, 28, 30 - 32	Input terminals
6 - 11, 20, 22-27	eala, ealaBASS, Other Filter terminals
18	Reference Voltage terminal

Application Circuit 2

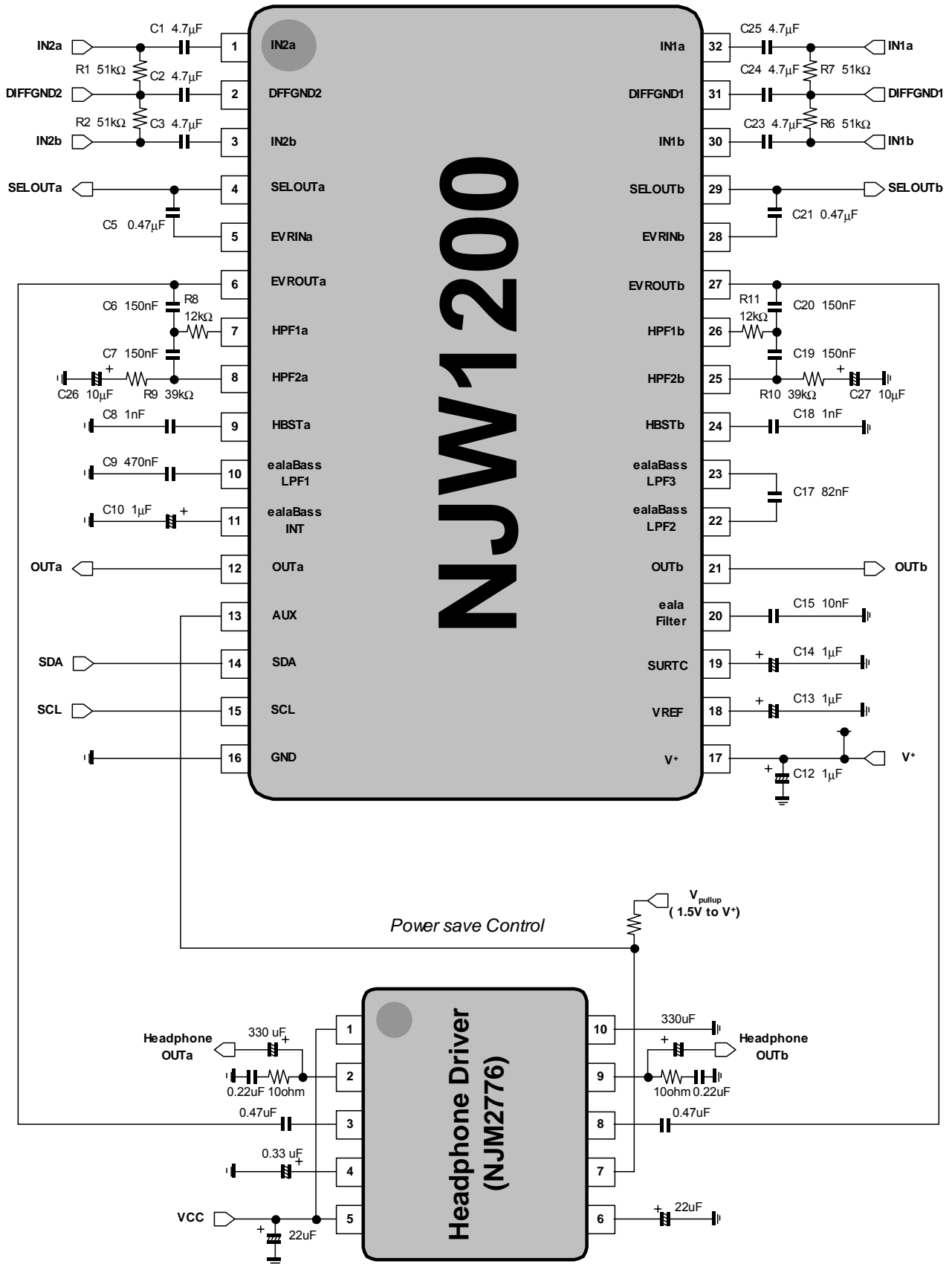

APPLICATION NOTE

(1) HPF

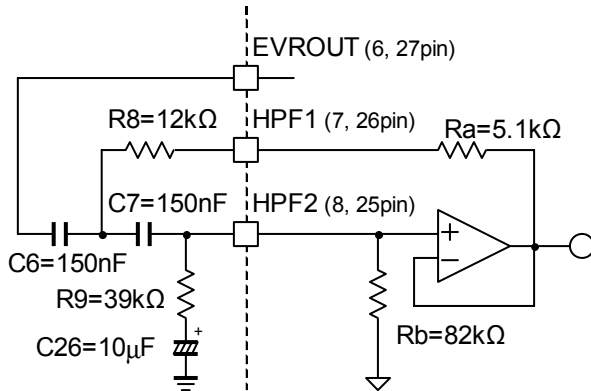

$$f_c = \frac{1}{2\pi\sqrt{(R_a + R_8) \cdot (R_b // R_9) \cdot C_6 \cdot C_7}}$$

$$Q = \frac{\sqrt{(R_a + R_8) \cdot (R_b // R_9) \cdot C_6 \cdot C_7}}{(R_a + R_8) \cdot C_6 + (R_b // R_9) \cdot C_7}$$

$$\therefore R_b // R_9 = \frac{R_b \cdot R_9}{R_b + R_9}$$

Voltage Gain vs Frequency (Bypass)
V+=3.3V, Vin(INa+INb)=0.1Vrms, Vout=OUTa

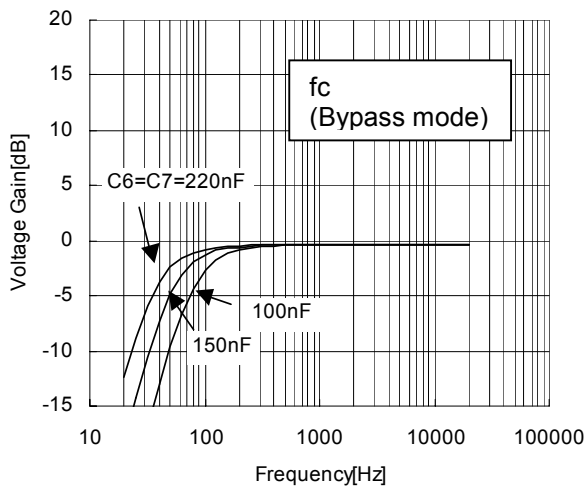

Voltage Gain vs Frequency (Bypass)
V+=3.3V, Vin(INa+INb)=0.1Vrms, Vout=OUTa

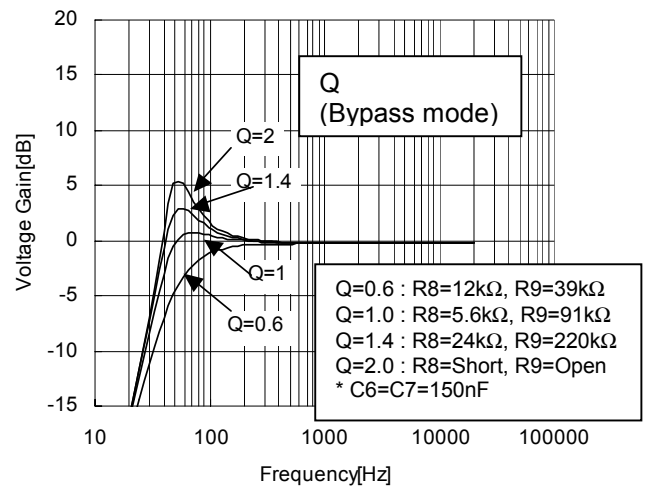

ealaBASS Characteristic
V+=3.3V, Vin(INa+INb)=0.1Vrms, Vout=OUTa
ealaBass=High, eala=off

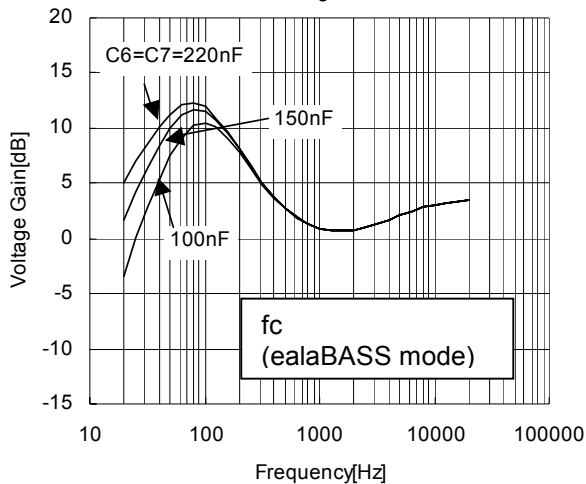

ealaBASS Characteristic
V+=3.3V, Vin(INa+INb)=0.1Vrms, Vout=OUTa
ealaBass=High, eala=off

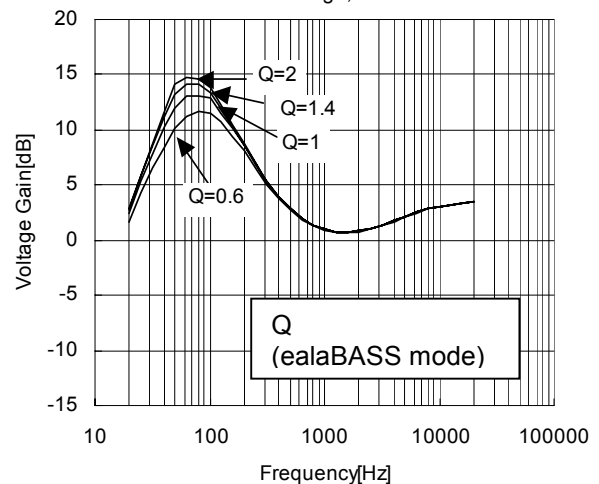

APPLICATION NOTE

(2) ealaBASS

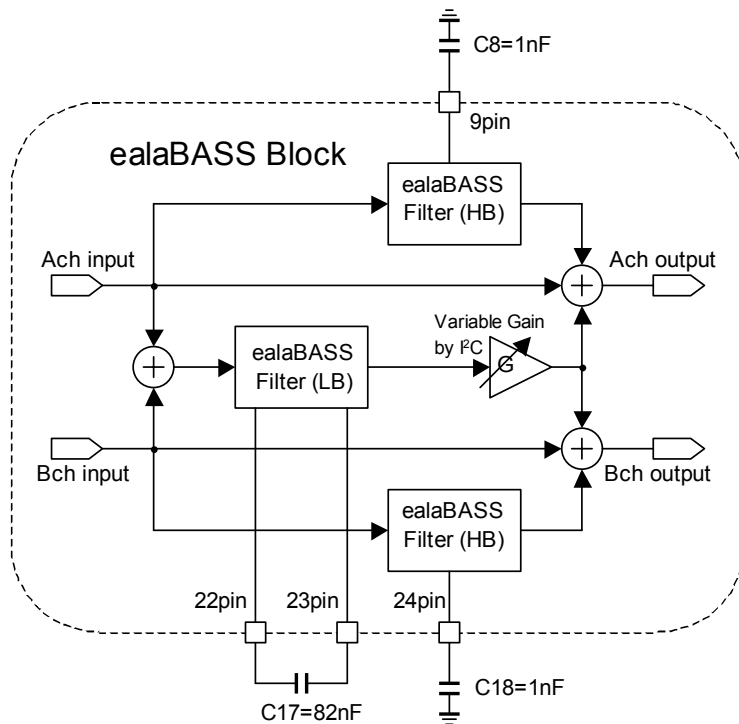

The ealaBASS Low Frequency effect depends on capacitor C17. Choosing small C17 value should produce high "Bass Boost" effect.

The ealaBASS High Frequency Compensation effect depends on capacitor C8 and C18. Choosing large C8 and C18 value should produce high "High Frequency Compensation" effect.

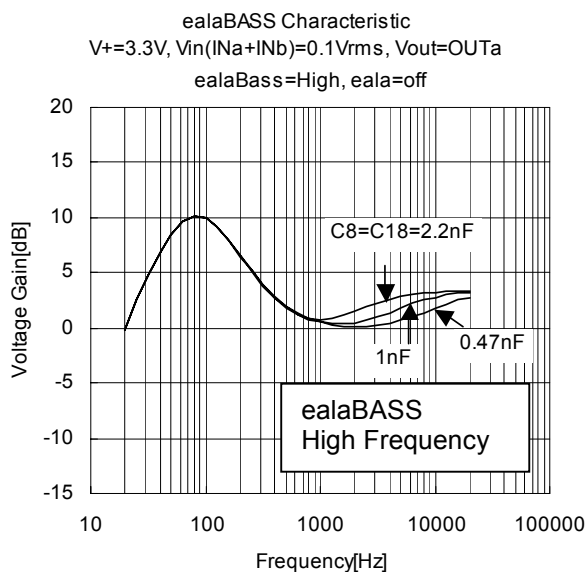
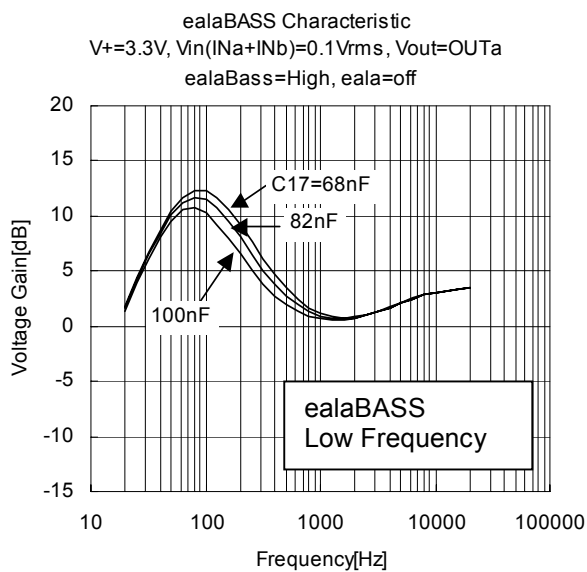

APPLICATION NOTE

(3) eala

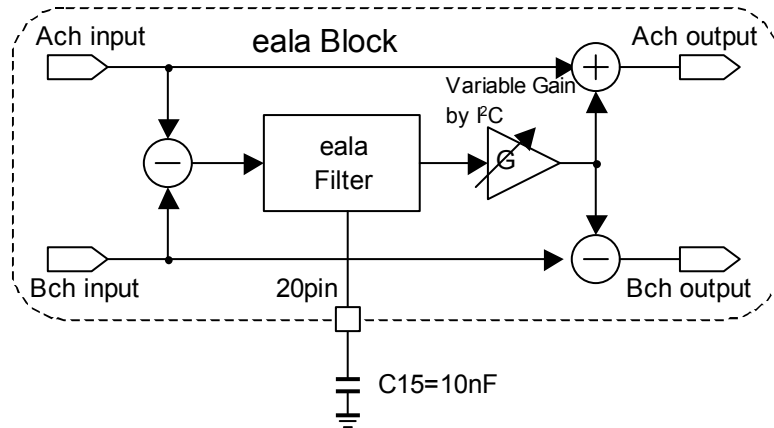

The eala effect depends on capacitor C15.
 Choosing small C15 value should produce high surround effect.

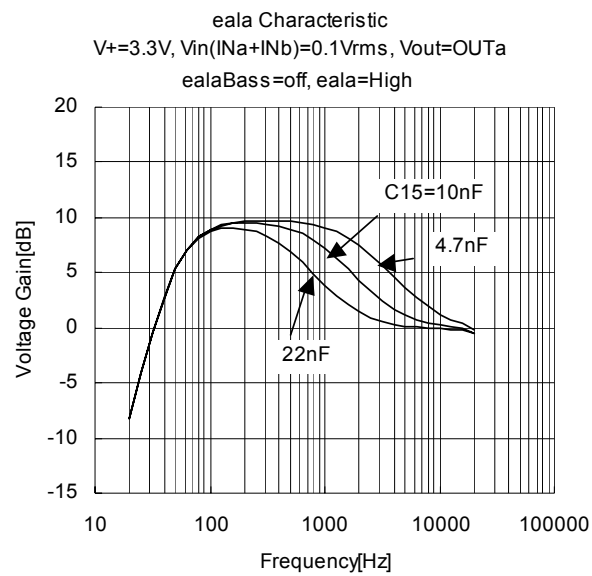

APPLICATION NOTE

(4) Channel Separation at the time of Differential Input use

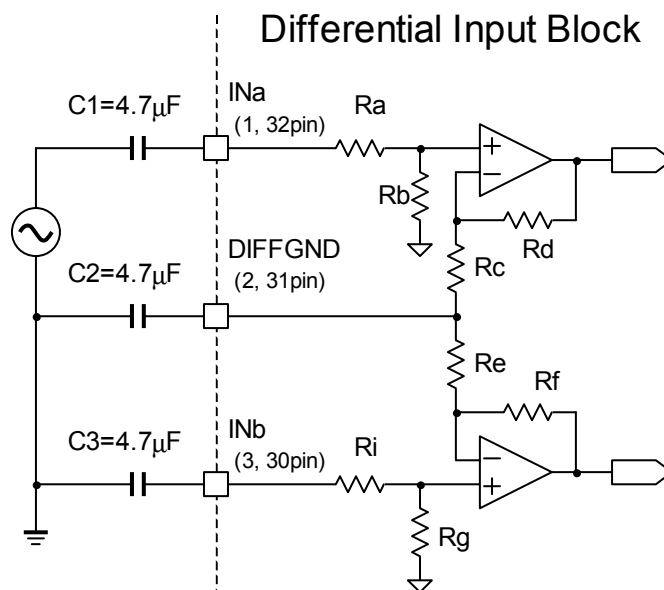

Channel Separation Measurement Circuit

Channel Separation at the time of Differential Input use is effected by LPF which consists of Rc (Re) and C2. High Channel Separation requires a large Input coupling capacitors (C1 to C3, C23 to C25).

In many case, however, the interval of speakers used in portable systems is narrow. Therefore High Channel Separation is not required so much. The input coupling capacitors value should be chosen based on needed Channel Separation.

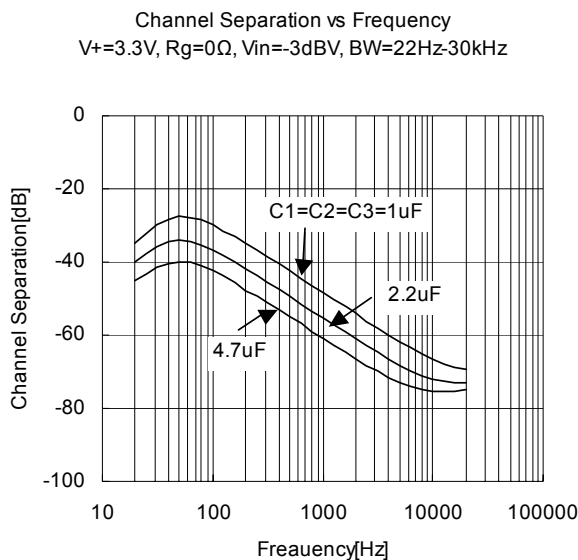

■ DEFINITION OF I²C REGISTER

◆ I²C BUS FORMAT

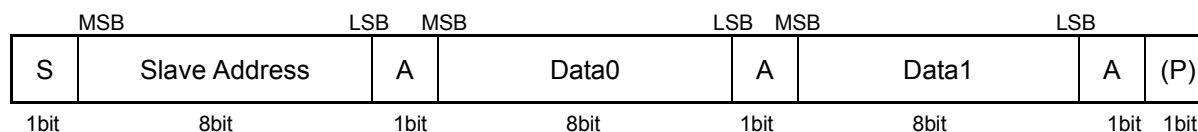

S: Starting Term
A: Acknowledge Bit
P: Ending Term

◆ SLAVE ADDRESS

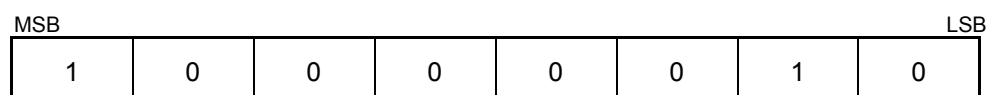

◆ CONTROL REGISTER TABLE

Data0						Data1									
D7	D6	D5	D4	D3	D2	D1	D0	D7	D6	D5	D4	D3	D2	D1	D0
PS	SEL	AUX	eala	ealaBass	eBSW	Don't Care		Volume							

◆ CONTROL REGISTER DEFAULT VALUE

Control register default value is all "0".

Data0						Data1									
D7	D6	D5	D4	D3	D2	D1	D0	D7	D6	D5	D4	D3	D2	D1	D0
0	0	0	0	0	0	0	0	-	-	0	0	0	0	0	0

■ INSTRUCTION CODE

•PS

Power save mode ON / OFF select

mode	Data0
	D7
ON	0
OFF	1

•SEL

INPUT1 / 2 select

select	Data0
	D6
INPUT1	0
INPUT2	1

•AUX

Auxiliary output High / Low select

control	Data0
	D5
High	0
Low	1

●eala

eala effect select

mode	Data0	
	D4	D3
OFF	0	0
eala MONO	0	1
eala Low	1	1
eala High	1	0

●eBSW

ealaBASS ON / OFF select

mode	Data0
	D0
ealaBASS OFF	0
ealaBASS ON	1

●ealaBass

ealaBASS effect select

effect	Data0	
	D2	D1
BB Low	0	0
BB Middle	0	1
BB High	1	0
--- *	1	1

* No Acceptable

●Volume : Volume control

Volume Level setting 0 to -78dB / 2dBstep, Mute

Gain(dB)	Data1					
	D5	D4	D3	D2	D1	D0
0dB	1	1	1	1	1	1
-2dB	1	1	1	1	1	0
-4dB	1	1	1	1	0	1
-6dB	1	1	1	1	0	0
-8dB	1	1	1	0	1	1
-10dB	1	1	1	0	1	0
-12dB	1	1	1	0	0	1
-14dB	1	1	1	0	0	0
-16dB	1	1	0	1	1	1
-18dB	1	1	0	1	1	0
-20dB	1	1	0	1	0	1
-22dB	1	1	0	1	0	0
-24dB	1	1	0	0	1	1
-26dB	1	1	0	0	1	0
-28dB	1	1	0	0	0	1
-30dB	1	1	0	0	0	0
-32dB	1	0	1	1	1	1
-34dB	1	0	1	1	1	0
-36dB	1	0	1	1	0	1
-38dB	1	0	1	1	0	0
-40dB	1	0	1	0	1	1
-42dB	1	0	1	0	1	0
-44dB	1	0	1	0	0	1
-46dB	1	0	1	0	0	0
-48dB	1	0	0	1	1	1
-50dB	1	0	0	1	1	0
-52dB	1	0	0	1	0	1
-54dB	1	0	0	1	0	0
-56dB	1	0	0	0	1	1
-58dB	1	0	0	0	1	0
-60dB	1	0	0	0	0	1
-62dB	1	0	0	0	0	0
-64dB	0	1	1	1	1	1
-66dB	0	1	1	1	1	0
-68dB	0	1	1	1	0	1
-70dB	0	1	1	1	0	0
-72dB	0	1	1	0	1	1
-74dB	0	1	1	0	1	0
-76dB	0	1	1	0	0	1
-78dB	0	1	1	0	0	0
MUTE	0	0	0	0	0	0

■ TYPICAL CHARACTERISTICS

Supply Current vs Temperature
(Active Mode) $V_+ = 3.3V$

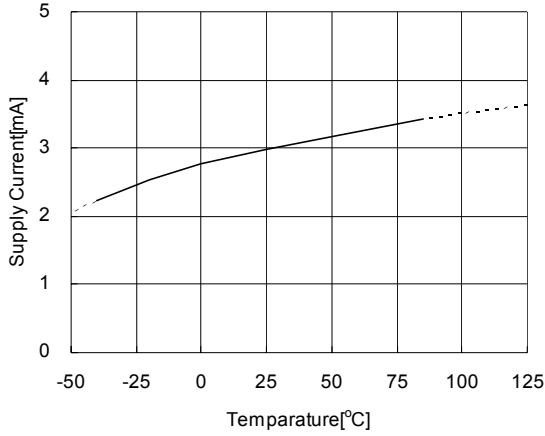

Supply Current vs Supply Voltage
(Active Mode)

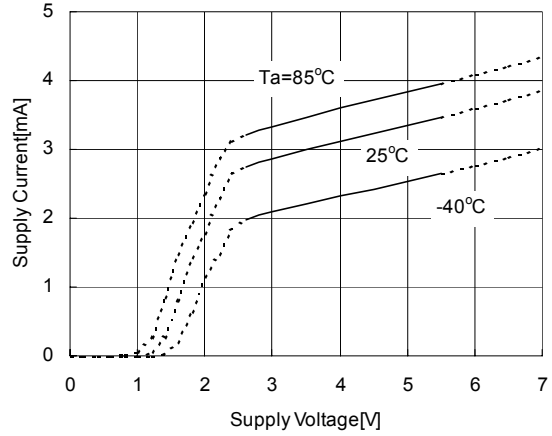

Supply Current vs Temperature
(Standby Mode) $V_+ = 3.3V$

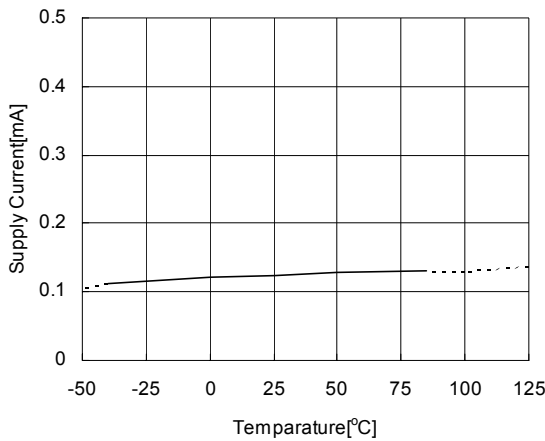

Supply Current vs Supply Voltage
(Standby Mode)

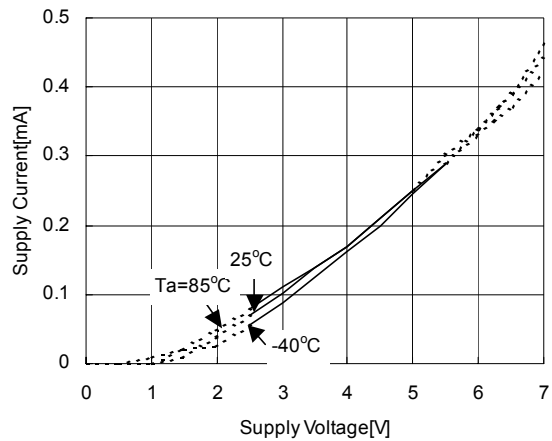

Reference Voltage vs Temperature
 $V_+ = 3.3V$

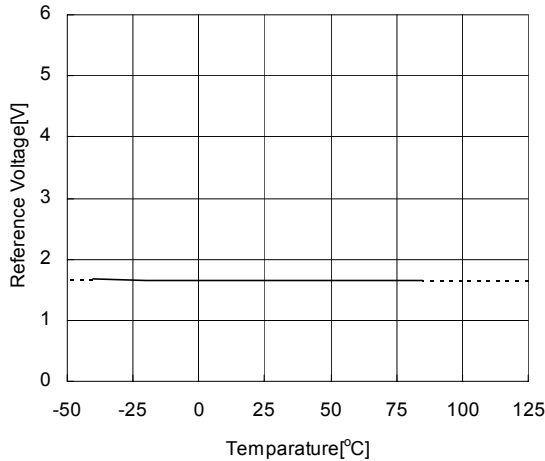

Reference Voltage vs Supply Voltage

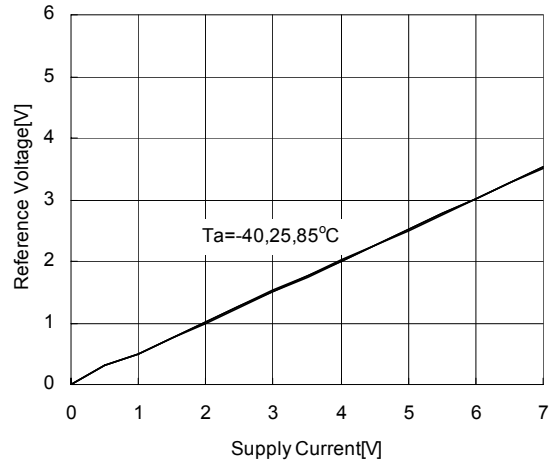

■ TYPICAL CHARACTERISTICS

Output Noise vs Temperature
 $V_+ = 3.3V$, $R_g = 0\Omega$, A-Weighting

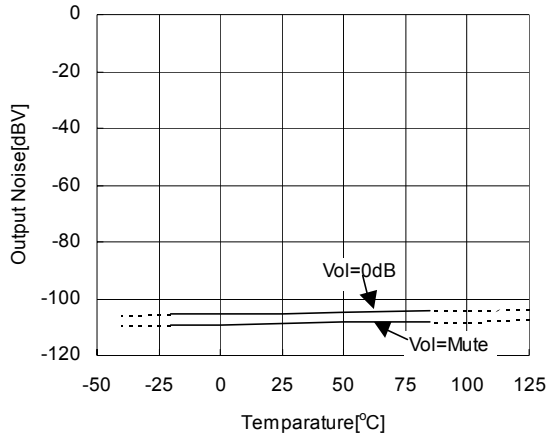

PSRR vs Frequency
 $V_+ = 3.3V$, $V_{ripple} = 50mV_{rms}$, $R_g = 0\Omega$, $T_a = 25^\circ C$

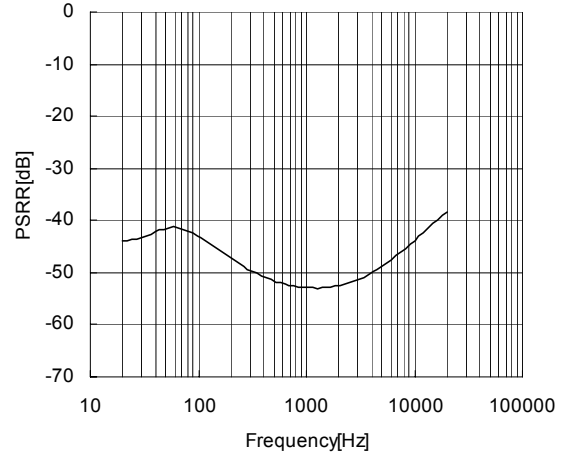

THD+N vs Output Voltage(Temperature)
 $V_+ = 3.3V$, $f = 1kHz$, $Vol = 0dB$, $BW = 400Hz - 30kHz$

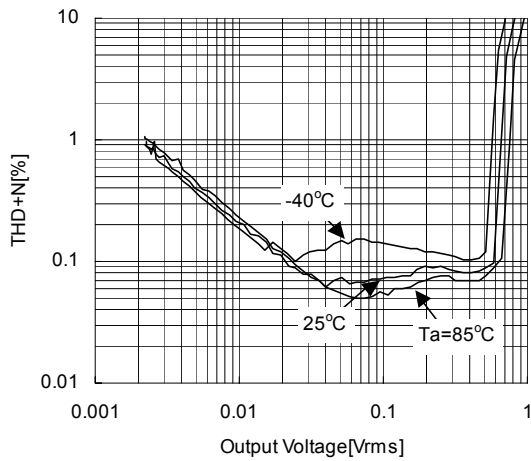

THD+N vs Output Voltage(Frequency)
 $V_+ = 3.3V$, $T_a = 25^\circ C$, $Vol = 0dB$, $BW = 400Hz - 30kHz$

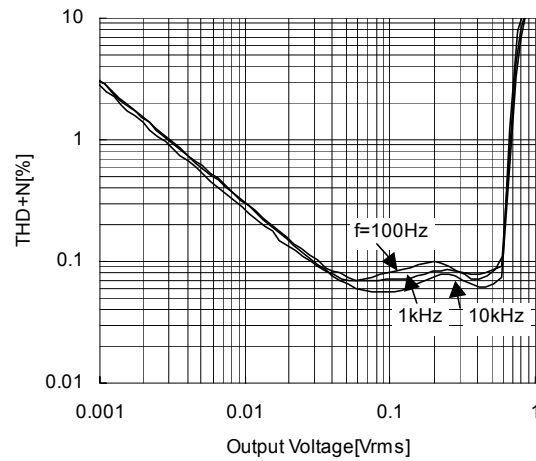

THD+N vs Output Voltage(VolumeControl)
 $V_+ = 3.3V$, $f = 1kHz$, $T_a = 25^\circ C$, $BW = 400Hz - 30kHz$

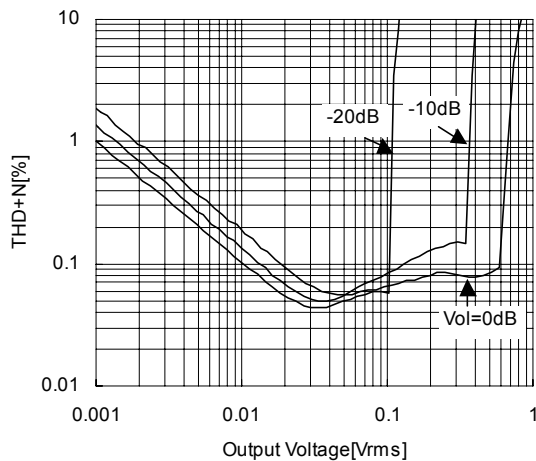

■ TYPICAL CHARACTERISTICS

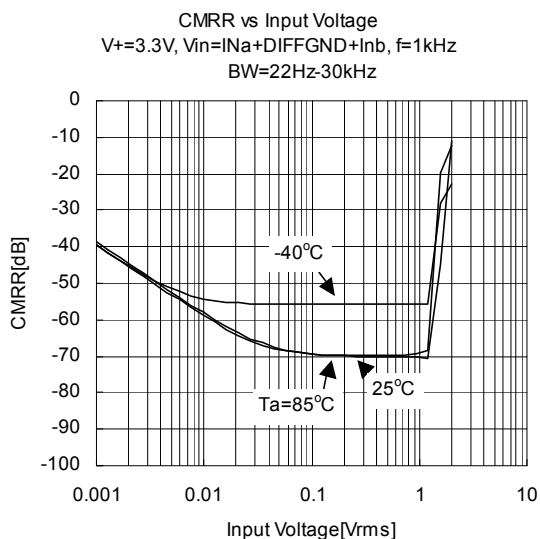
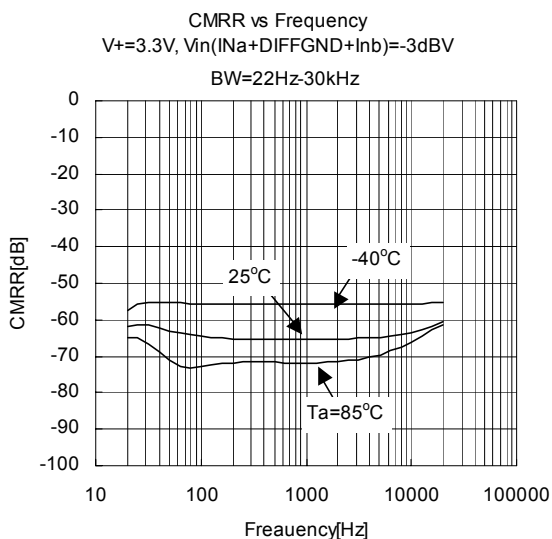
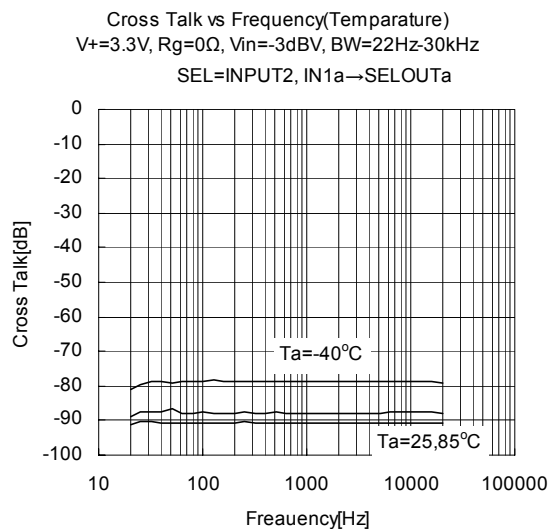
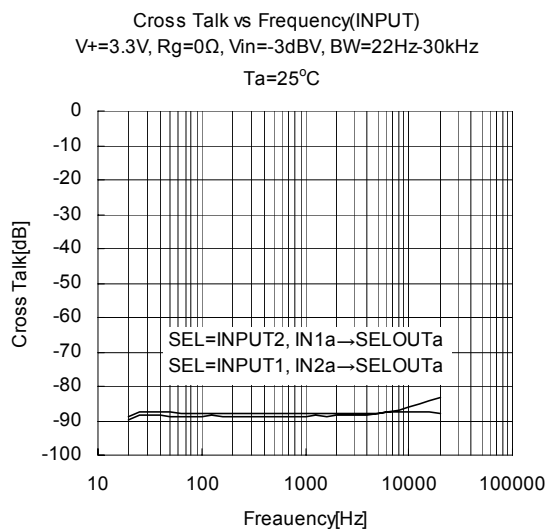
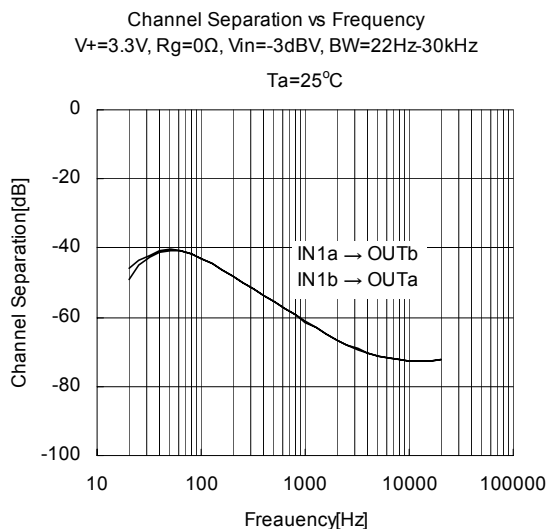
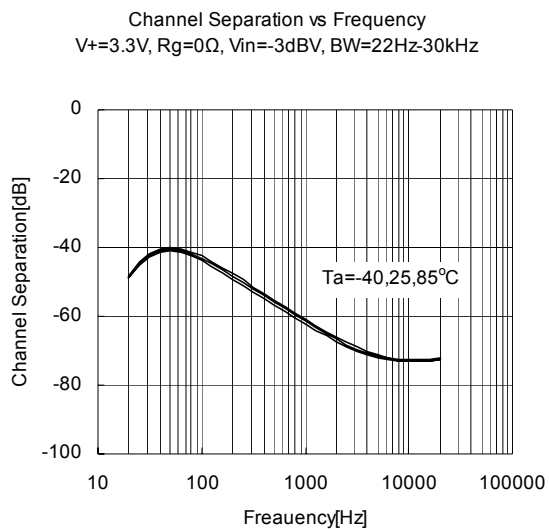

■ TYPICAL CHARACTERISTICS

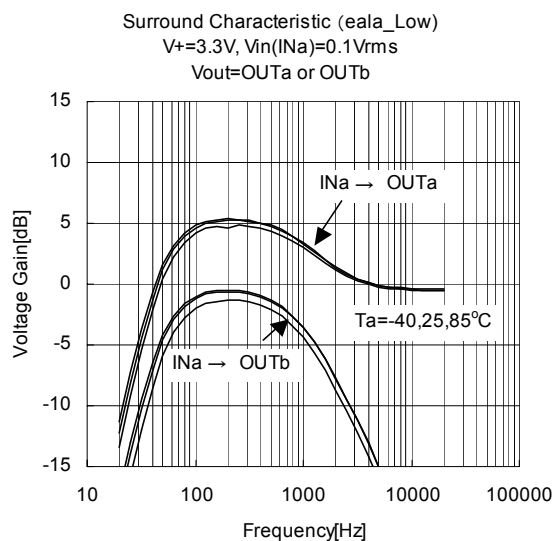
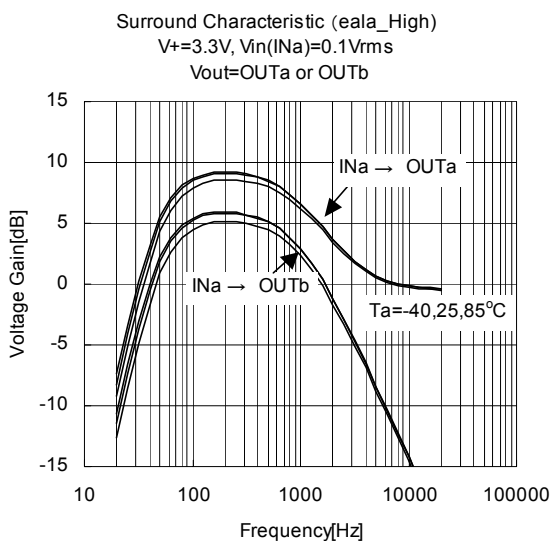
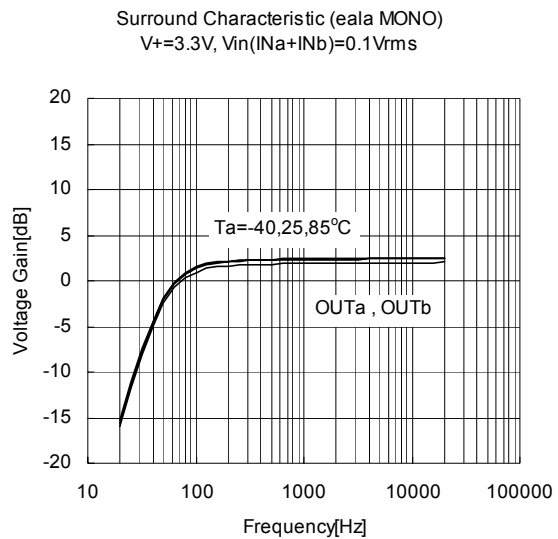
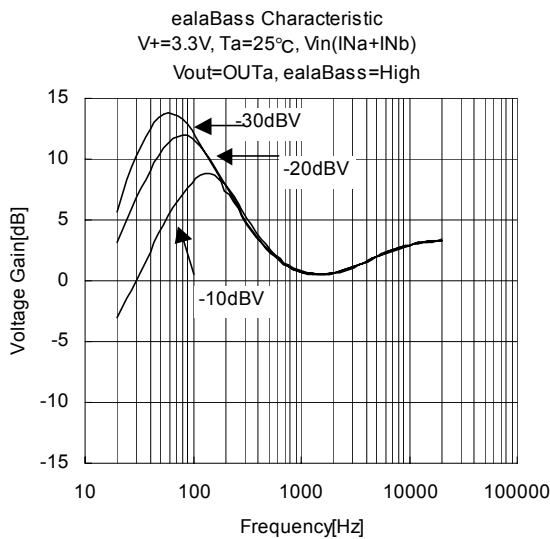
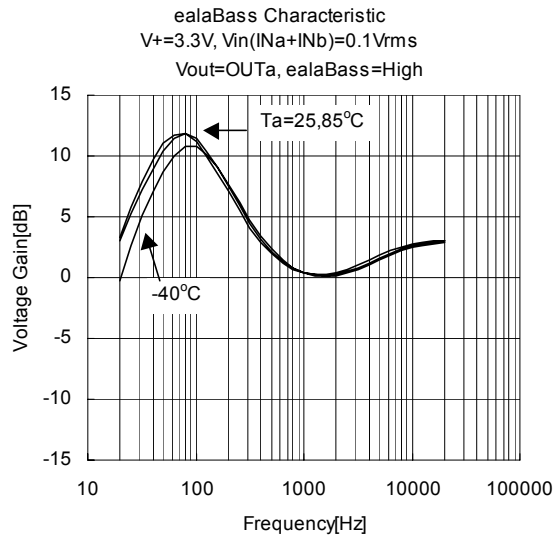
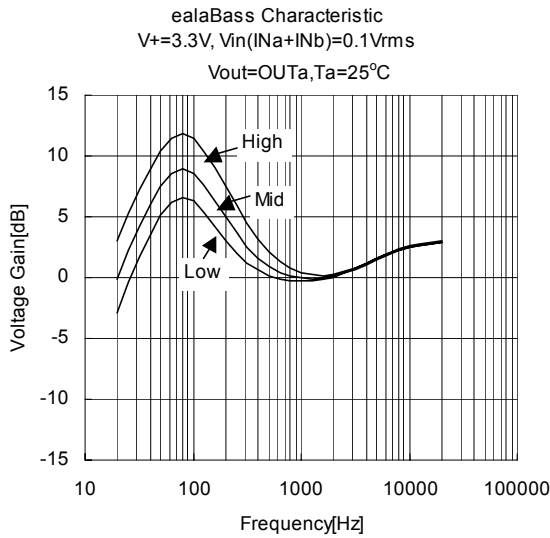

■ TYPICAL CHARACTERISTICS

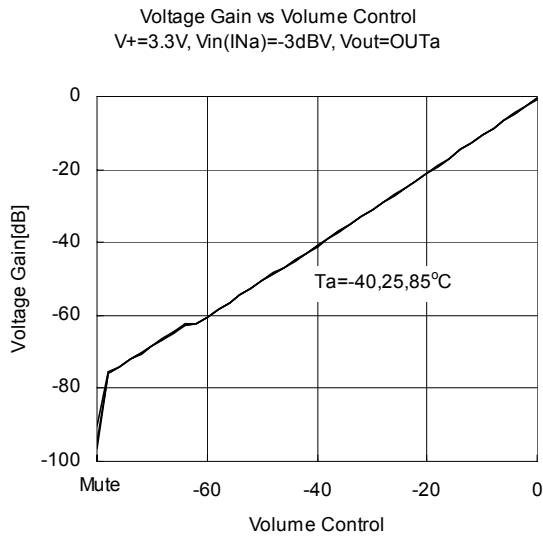

[CAUTION]
The specifications on this databook are only given for information, without any guarantee as regards either mistakes or omissions. The application circuits in this databook are described only to show representative usages of the product and not intended for the guarantee or permission of any right including the industrial rights.