

© COPYRIGHT 1998 BY SPC TECHNOLOGY. ALL RIGHTS RESERVED. NO PORTION OF THIS PUBLICATION, WHETHER IN WHOLE OR IN PART CAN BE REPRODUCED WITHOUT THE EXPRESS WRITTEN CONSENT OF SPC TECHNOLOGY.

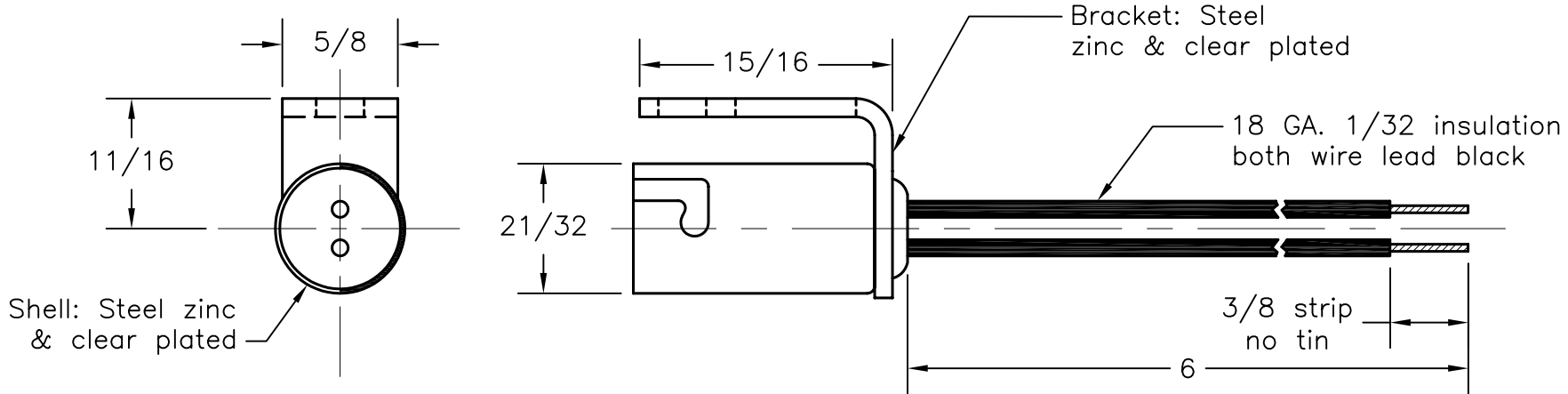

REVISIONS			DOC. NO. SPC-F005, Total Pages: 2 Effective: 7/15/97. DCP No: 229 Supersedes DCP No: 103					
DCP #	REV	DESCRIPTION	DRAWN	DATE	CHECKD	DATE	APPRVD	DATE
1946	A	RELEASED	SA	1/10/07	JWM	3/19/07	TL	3/19/07

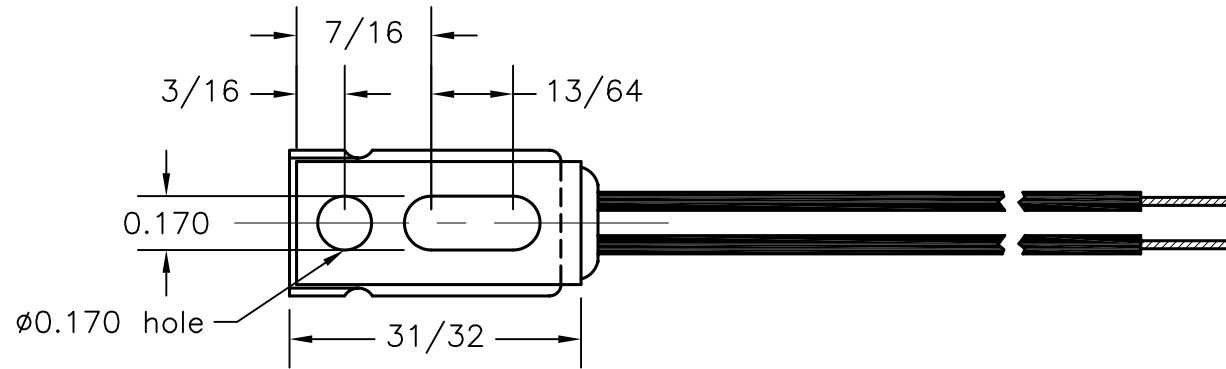

<small>DISCLAIMER: ALL STATEMENTS AND TECHNICAL INFORMATION CONTAINED HEREIN ARE BASED UPON INFORMATION AND/OR TESTS WE BELIEVE TO BE ACCURATE AND RELIABLE. SINCE CONDITIONS OF USE ARE BEYOND OUR CONTROL, THE USER SHALL DETERMINE THE SUITABILITY OF THE PRODUCT FOR THE INTENDED USE AND ASSUME ALL RISK AND LIABILITY WHATSOEVER IN CONNECTION THEREWITH.</small>		
TOLERANCES UNLESS OTHERWISE SPECIFIED. FRACTION: ±1/64 DECIMAL: 3 PLACES: ±.005	DRAWN BY: SAMI ALNADI	DATE: 1/10/07
	CHECKED BY: JEFF MCVICKER	DATE: 3/19/07
	APPROVED BY: THOMAS LEE	DATE: 3/19/07



SPC TECHNOLOGY

DRAWING TITLE: Double Contact Candelabra Bayonet Lampholder			
SIZE A	DWG. NO. SPC21741	ELECTRONIC FILE 16M1232.DWG	REV A
SCALE: NTS	U.O.M.: INCHES [mm]	SHEET: 1 OF 1	