

A1	GND	B12	GND
A4	VBUS	B9	VBUS
A5	CCI	B8	SBU2
A6	DPI	B7	DN2
A7	DNI	B6	DP2
A8	SBU1	B5	CC2
A9	VBUS	B4	VBUS
A12	GND	B12	GND
PIN	SIGNAL NAME	PIN	SIGNAL NAME

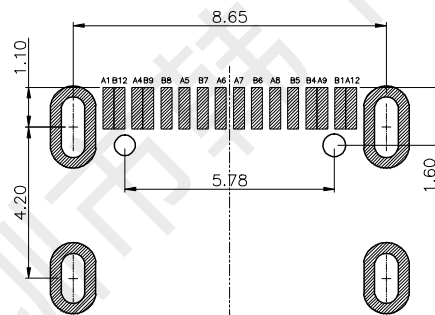
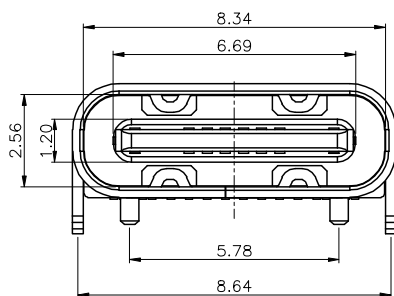
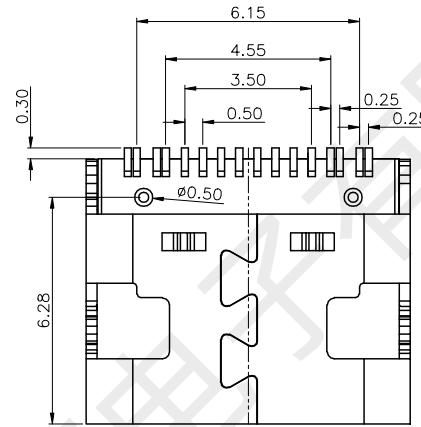
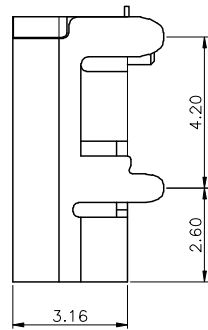
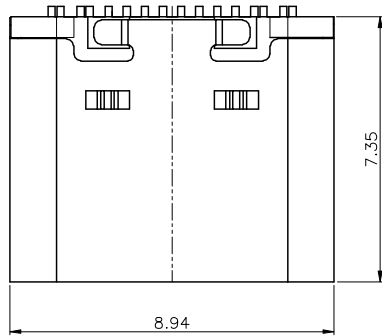

PCB LAYOUT(Recommend)
(General Tolerance:±0.05)

规格说明 Specifications:

1. 电气特性 Electrical:

- 额定电压(Rated voltage): 20V DC
- 额定电流(Rated current): 3A VBUS引脚;
1.25A用于GND引脚, 其他引脚为0.25A.
- 接触电阻(Contact resistance): 40mΩ Max
- 测试条件: 20mv, 100mA下测量.
- 绝缘电阻(Insulation resistance): 100MΩ Min
- 耐电压(Withstand Voltage): 100V AC

2. 机械性能 Mechanical:

- 插入力(Mate force): 0.5-2.0Kg
- 拔出力(Unmate force): 0.6-2.0Kg
- 插拔次数(Durability): 5000 Cycles.

3. 材料 Material:

- 胶芯(Housing): LCP UL94 V-0
- 端子(Contact): C2680, T=0.2mm; 镍底, 镀金
- 外壳(Shell): 不锈钢201-H 表面镀镍

4. 温度范围(Temperature Range): -30°C to +80°C.

UNLESS OTHERWISE SPECIFIED TOLERANCES		深圳市韩下电子有限公司			
DECIMALS:	ANGLES	TITLE. TYPE-C 16Pin四脚插板SMT 073			
X. ±0.20	X' ±2'	Drwn.	李春风	PART NO.	HX TYPE-C 16PIN
X.X ±0.15	X.X' ±1'	Checked.	钟华华	SCALE.	1:8
X.XX ±0.10	X.XX' ±0.5'	Approved.	罗孝金	UNIT.	mm
X.XXX ±0.05				SIZE.	A4
				SHEET.	1 of 1
				REV.	A
CUSTOMER COPY					