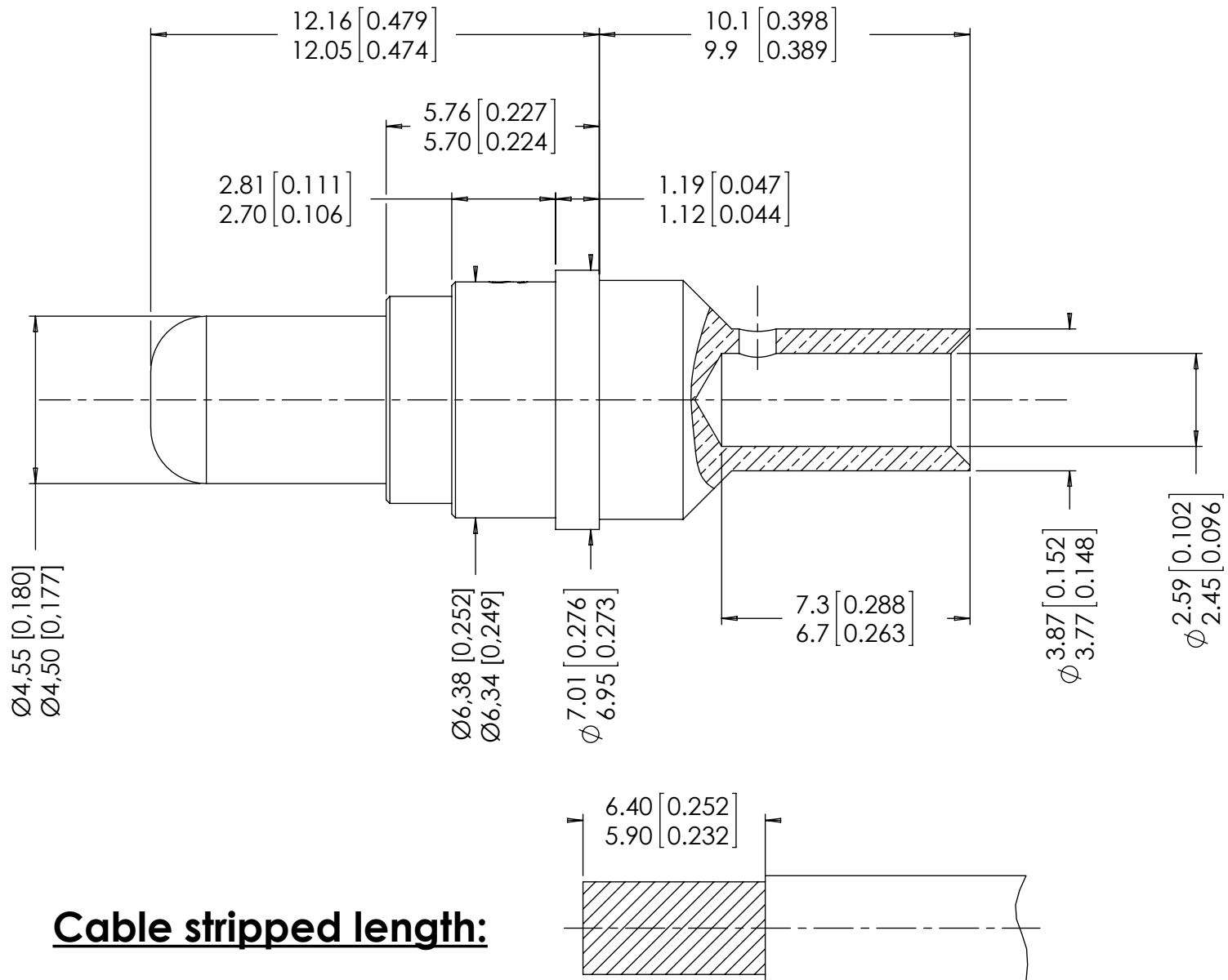
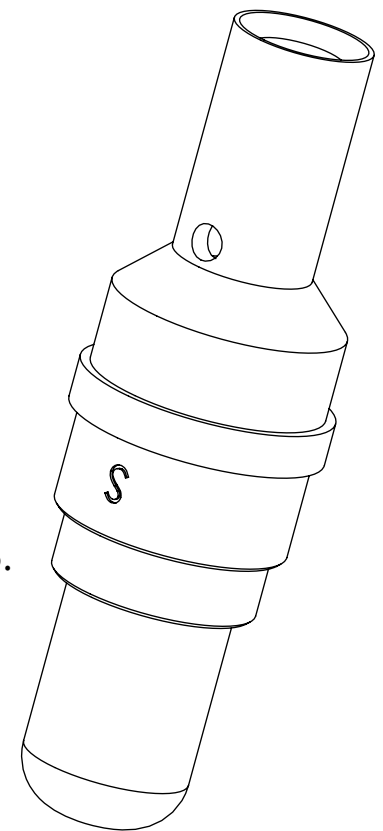
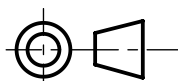

**Series
EPX**
**Power crimp pin contact
For size 5 cavity.
For AWG 12, AWG14 and AWG 16 wires.**
**Issue:
Sept. 12, 2014**
**Page
1/1**

Material and finish: Copper alloy, gold over nickel.

Crimping tool for AWG 12, AWG 14 & AWG 16 , RADIALL P/N: 282 613.
Positioner FOR AWG 12, AWG 14 & AWG 16, RADIALL P/N: 282 586 003.
Selector setting for AWG 12 : 6.
Selector setting for AMG14 & AWG 16 : 4.

Extraction tool: M81969/28-01, RADIALL P/N: 282946.

DIMENSIONS : mm (inch are given for information only)

Estimated weight : 3.7 g

CREATION				
PEN: M020400013A	Sept. 12, 14	Added AWG14 wires. and estimated weight	Surault	VIEIRA
	Jan. 12, 10	Added AWG16 wires.	Surault	Le Gloahec
NOM: CHEVREAU G.	09.30.08	"S" added on contact.	S.Malty	M.Pessard
	02.19.03	P/N 617260001 was RP56066.	L.Garcia	C.Lahoreau
DATE: Feb. 07, 2002	03.08.02	Positioner P/N added.	L.Garcia	G.Motteau
APPR.: G.Motteau	Issue	Revisions	Name	Approved

617260001EN

RADIALL PROPRIETARY INFORMATION

This document contains proprietary information and such information shall not be disclosed to any third party for any purpose whatsoever or used for manufacturing purposes without prior written agreement from RADIALL. This information is given as an indication. In the continual goal to improve our products, we reserve the right to make any modifications judged necessary.

4112_9311

Mouser Electronics

Authorized Distributor

Click to View Pricing, Inventory, Delivery & Lifecycle Information:

[Radial:](#)

[617260001](#)