

PRODUCT NO. DSIC01LHGET	RoHS compliant
----------------------------	----------------

REV.	ECN NO.	DR	DATE

NOTES :

- 1.Specification:
 1>.Operating force:1000gf Max
 2>.Operating Temperature:-40° to+85°
 3>.Storage Temperature::-40° to+85°
 4>.Mechanical Life:3000cycles minimum
 5>.Electrical Life:2000cycles 25mA 24VDC

2. PLATING:
 GOLD FLASH 1u"~2u" SOLDER TAIL,
 1u"~3u" GOLD PLATING ON THE CONTACT AREA,
 WITH 50u" NICKEL UNDERPLATING OVERALL.

3. PART NUMBER DESCRIPTION

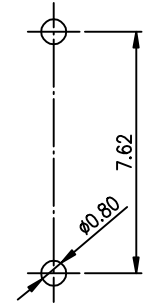
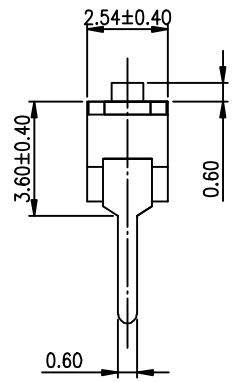
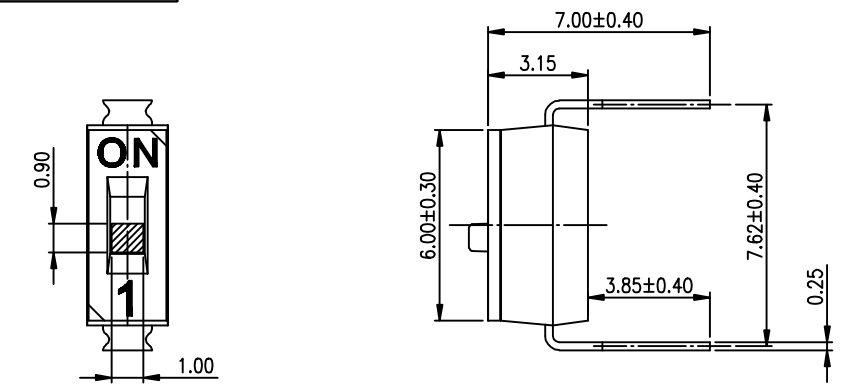
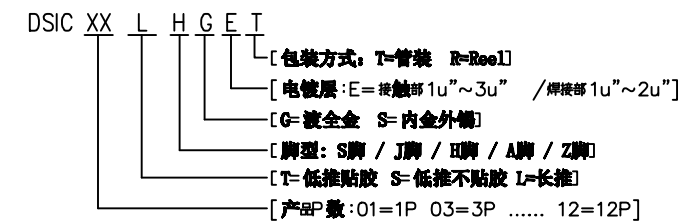

RECOMMENDED P.C.B. LAYOUT (TOP VIEW)

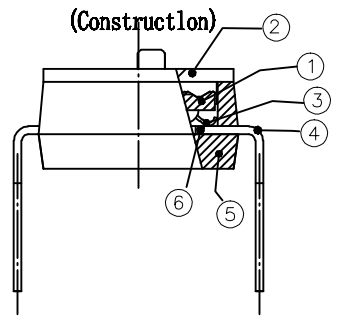

[Schematic]

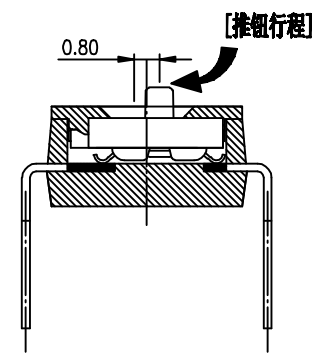

Number	Part Name	Material	Finished	TOLERANCE UNLESS OTHERWISE SPECIFIED		INSPECTION COPY	东莞市广普实业有限公司 DongGuan Kingtek Industrial Co., Ltd.										
				LINER	ANGLES												
①	Actuator	UL94 V0	White	.0 ± 0.25	0. ± 2'	PROJECTION 2012/04/12	TITLE										
②	Cover	UL94 V0	Black	.00 ± 0.15	.0 ± 1'		BY DSIC SERIES PITCH 2.54mm										
③	Movable	Copper Alloy	1u"~3u"Gold	.000± 0.10	.00± 0.5'		PRODUCT FAMILY DSIC SERIES										
④	Terminal	Brass	1u"~2u"Gold	DESIGN	kathy		PRAT NO.										
⑤	Base	UL94 V0	Black	DRAWING			DSIC01LHGET										
⑥	Terminal Contact	Brass	1u"~3u"Gold	CHECK			FILE NO. DSIC01LHGET-A										
				APPRO.			<table border="1"> <tr> <th>SIZE</th> <th>UNIT</th> <th>SCALE</th> <th>SHEET</th> <th>REV.</th> </tr> <tr> <td>A4</td> <td>mm</td> <td>2 : 1</td> <td>1 OF 1</td> <td>A</td> </tr> </table>	SIZE	UNIT	SCALE	SHEET	REV.	A4	mm	2 : 1	1 OF 1	A
SIZE	UNIT	SCALE	SHEET	REV.													
A4	mm	2 : 1	1 OF 1	A													