

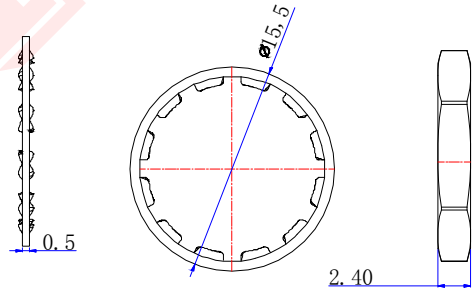

Product NO.		DOSIN-801-0035		
REV	DESCRIPTION	DWN	DATE	APPROVEN
A	First issue	CHEN	2018/2/25	John kine

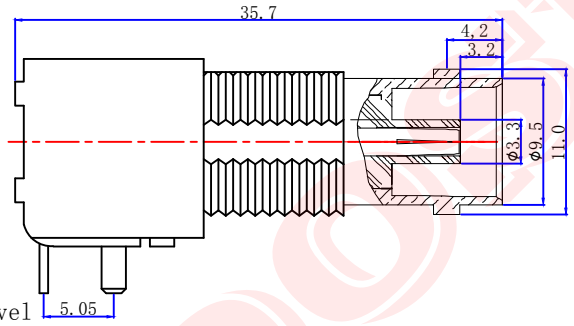
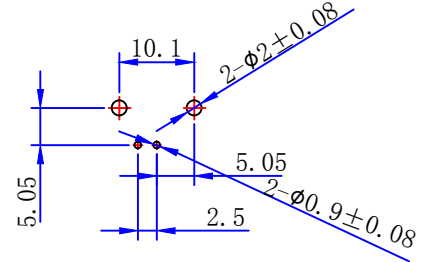
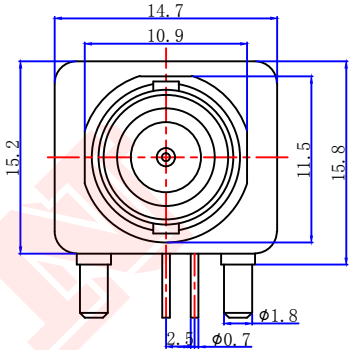
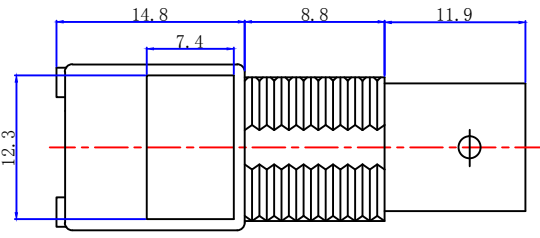
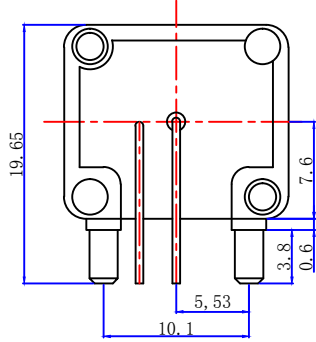

WASHER

NUT

**Specifications**

Impedance: 75 Ohms  
 Frequency Range: DC~3G  
 VSWR: 1.3MAX  
 Working Voltage: 500V rms @ sea level  
 Insulation Resistance: 5000 Ohms min  
 Temperature Range: -55°C TO +155°C  
 Relative Temperature: ≤95% (40° C ± 2° C)  
 Drawings products are in line with ROHS standards

1	Body	ZINC3#	NI: 80-120"	1	NOTE:	Tolerance	0-6	±0.15	<b>Dosin Industrial(H.K)Co.Ltd</b> 东莞市德索五金电子制品有限公司 Dosin Hardware Electronics Co.,Ltd E-mail: dosin2005@163.com dosin2005@dosing-china.com Web: http://www.dosinconn.com TEL: (0086)769-81153906 FAX: (0086)769-81875836	
2	Center contact<1>	Cl7200	AU: 0.8-1.0"	1			DRAWN Zelin. CHEN 2018/2/25	6-30		±0.20
3	Center contact<2>	Brass59-1	AU: 0.8-1.0"	1				CHECKED		30-120
4	Ground	Iron	SN: 80-100"	1			APPROVALS John 25.2.2018			Angular
5	fixed foot	Iron	SN: 80-100"	2				UNIT		MM
6	nut	Brass59-1	NI: 80-120"	1	APPROVALS	SCALE	1:1	Name:	BNC CONNECTOR DNN	
7	Insulator<1>	POM	White	1	King	DateTime	2018/2/25	CAD FILE	D/company drawings/BD	
8	Insulator<2>	POM	White	1						SIZE
9	washer	Iron	NI: 80-120"	1	QTY	SCALE	1:1	SHEET: 1 OF 1		